

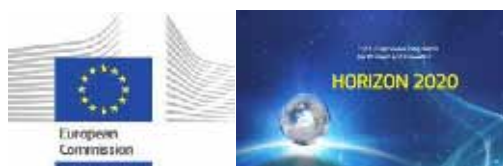



H2020-TWINN-2015. Grant Agreement no 691936	
Project full title:	Remote Sensing Science Center for Cultural Heritage
Project acronym:	ATHENA
Work Package	WP4
Deliverable	D4.1 Report of the 1 st Summer School



© Copyright by the **ATHENA** consortium, 2015-2018. The project that has received funding from the European Union's Horizon 2020 research and innovation programme under grant agreement No 691936 (H2020-TWINN-2015). More info regarding the project you can find here: www.athena2020.eu

DISCLAIMER: This document contains material, which is the copyright of **ATHENA** consortium members and the European Commission, and may not be reproduced or copied without permission, except as mandated by the European Commission Grant Agreement No 691936 for reviewing and dissemination purposes. The information contained in this document is provided by the copyright holders "as is" and any express or implied warranties, including, but not limited to, the implied warranties of merchantability and fitness for a particular purpose are disclaimed. In no event shall the members of the **ATHENA** consortium, including the copyright holders, or the European Commission be liable for any direct, indirect, incidental, special, exemplary, or consequential damages (including, but not limited to, procurement of substitute goods or services; loss of use, data, or profits; or business interruption) however caused and on any theory of liability, whether in contract, strict liability, or tort (including negligence or otherwise) arising in any way out of the use of the information contained in this document, even if advised of the possibility of such damage.

	<p>H2020-TWINN-2015 Grant Agreement no 691936 This project is funded under the EUROPEAN COMMISSION in the Framework Programme for Research and Innovation (2014-2020).</p>	
Call:	Work programme H2020 under “ Spreading Excellence and Widening Participation ”, call: H2020-TWINN-2015: Twinning (Coordination and Support Action).	
Project full title:	Remote Sensing Science Center for Cultural Heritage	
Project acronym:	ATHENA	
Work Package (WP):	WP4	
Deliverable (D):	D4.1 (Report of the 1stsummer school)	
Due date of deliverable:	June 2016 (Month 7 of the project)	Version:1
Author(s):	Ramon Brcic, Michael Eineder, Gunter Schreier	
Contributor(s):	Vasiliki Lysandrou, Athos Agapiou, Diofantos G. Hadjimitsis	
Start date of project:	1/12/2015	Duration:36 months

Dissemination Level		
PU	Public	√
CO	Confidential, only for members of the consortium (including the Agency Services)	☐

Document Sign-off				
Nature	Name	Role	Partner	Date
DRAFT	Ramon Brcic, MichaelEineder Gunter Schreier	Work Package Leader / Partner 2	DLR	02/06/2016
REVIEWED	Diofantos G. Hadjimitsis Athos Agapiou Vasiliki Lysandrou	Project leader	CUT	08/06/2016
APPROVED	Diofantos G. Hadjimitsis Gunter Schreier	Project Leader Partner 2	DLR/CUT	14/06/2016

Work Package: 4– Training and knowledge transfer				
Deliverable: D4.1–Report on the 1 st summer school				
Sections to be protected	Description	Owner	Access Rights	
			Period	Type*
none				

Table of Contents

Summary..... 6

1. Introduction..... 7

2. Agenda of the summer school..... 9

3. List of Participants.....11

4. Presentations during the summer school15

5. Pictures from the 1st Summer School16

ANNEX.....19

Summary

The specific deliverable summarizes the material related to the first summer school of the project entitled 'Interferometry / Radar'. The deliverable includes actions completed prior the accomplishment of the summer school, such as the agenda prepared, as well as material deriving from the summer school per se, such as the presentations, the list of participants, picture with the participants and stakeholders etc.

1. Introduction

The 1st Summer School of ATHENA project has been successfully accomplished in line to the timeline of the project. The ATHENA SAR Summer School took place on CUT premises in Limassol, Cyprus from the 23rd to 25th of May 2016. Visiting SAR scientists from the SAR Signal Processing Department of DLR (Department head Prof Dr Michael Eineder and research scientist Dr Ramon Brcic) met with members of the Remote Sensing and Geo-Environment Research Lab to introduce them to the concepts of SAR including how to access and process such data, but also to visit the UNESCO World Heritage archaeological site of NeaPaphos and thereby gain an understanding of the problems facing those working to preserve sites of cultural heritage.

On Monday the fundamentals of both SAR and interferometric SAR were covered. This included numerous examples of their application in practice. The summer school began with a brief introduction to the Remote Sensing Technology Institute of DLR by Prof Michael Eineder. The topic then turned to SAR fundamentals where the concepts of SAR imaging, geometry and focusing were explained. Following this, SAR image characteristics were described. Here, one is essentially concerned with what can be seen in SAR images and how to interpret this. Concepts covered included speckle, radar cross-section, SAR polarimetry, penetration characteristics at different carrier frequencies and the unique radar geometry which leads to layover and shadow. To round-up the morning, many examples of the uses of SAR in practice were given. These ranged over diverse applications such as oceanography, maritime security and ship detection, the use of SAR in crisis situations after earthquakes, volcanic eruptions and flooding, and in glaciology, geodesy, urbanisation, agriculture and traffic monitoring. Finally, some information on further educational resources was given including the ESPACE master's program at TUM (Technische Universität München), the one week SAR Principles and Application course offered by the CCG (Carl-Cranz Gesellschaft) and the freely offered SAREDU course which is jointly coordinated by the Friedrich-Schiller University Jena and DLR with support from BMWi (German Federal Ministry for Economic Affairs and Technology).

Building on this, the topic in the afternoon turned to interferometry where 2 or more SAR images are combined to extract information about, among others, changes on the earth's surface. Although there are a myriad of applications, the first and perhaps the most well-known is the generation of highly accurate topographic maps. For instance, the TanDEM-X mission will produce a homogeneous world-wide DEM with unprecedented absolute vertical accuracy better than 10 metres and a horizontal resolution of 12 metres. Another important

application is the ability to monitor surface deformation with millimetre accuracy. Indeed, monitoring deformation over tectonic regions world-wide is one of the main tasks of ESA's Sentinel-1 mission consisting of 2 SAR satellites, the second of which was launched in April 2016. The information gleaned from this mission is expected to revolutionise our understanding of the earth's tectonics and aid in the monitoring of earthquakes and volcanism. Other applications include landslide monitoring and velocity estimation of glacier flows, vehicles travelling on highways and tidal currents. Analysis of an interferometrically compatible stack of 20 or more SAR images can provide estimates of surface deformation with a precision on the order of 1 mm/year. Such techniques can provide important information about the long-term stability of archaeological sites. Aside from the plethora of practical applications, the basics of interferometry were also elaborated, starting from how such images are acquired through to the typical processing steps of coregistration and phase unwrapping including the noise sources that arise and their characteristics. Finally, an overview of current SAR missions was given with respect to their use for interferometry.

On Tuesday, the summer school visited NeaPaphos, the designated testsite for evaluating the use of high-resolution SAR based techniques in archaeology. Visual inspection of the site itself aids in the understanding and interpretation of SAR images which possess a different geometry and characteristics compared to optical images.

The visit set the stage for Wednesday where the theme was SAR data including how to obtain it, process it, what exists over Cyprus and the NeaPaphostestsite and a first look at SAR images and interferograms over the testsite. The focus was on high-resolution staring spotlight mode data from the TerraSAR-X mission especially acquired for ATHENA through a TerraSAR-X science proposal. The process of proposal submission and how to order data was also described. The same was done for the Sentinel-1 mission where free access is provided via the sentinel science hub. The large amount of data already available was acquired from various sensors in different modes and geometries, and was processed to provide several products, each bringing out different features in the data. Although only a cursory examination was possible during the summer school, this already showed the potential of SAR in highlighting features that are less visible with other techniques. A thorough joint evaluation of this data by SAR experts from DLR and archaeological experts from CUT is the next step.

Two main objectives for the future were defined. The first concerned data acquisition and included the planning of further TerraSAR-X datatakes over NeaPaphos, access to TanDEM-X CoSSCs and DEMs, and the download of actual Sentinel-1 data over Cyprus and historical

data from the ERS and ENVISAT missions. The second concerned processing this data where the aim is to enable CUT to process and interpret the data themselves. This includes deciding what type of processing is useful, which will become clearer after a detailed examination of the data, and which software packages can be most effectively leveraged to carry this out.

The summer school ended with a brief but interesting tour through the CUT campus which is spread out over Limassol city.

2. Agenda of the summer school

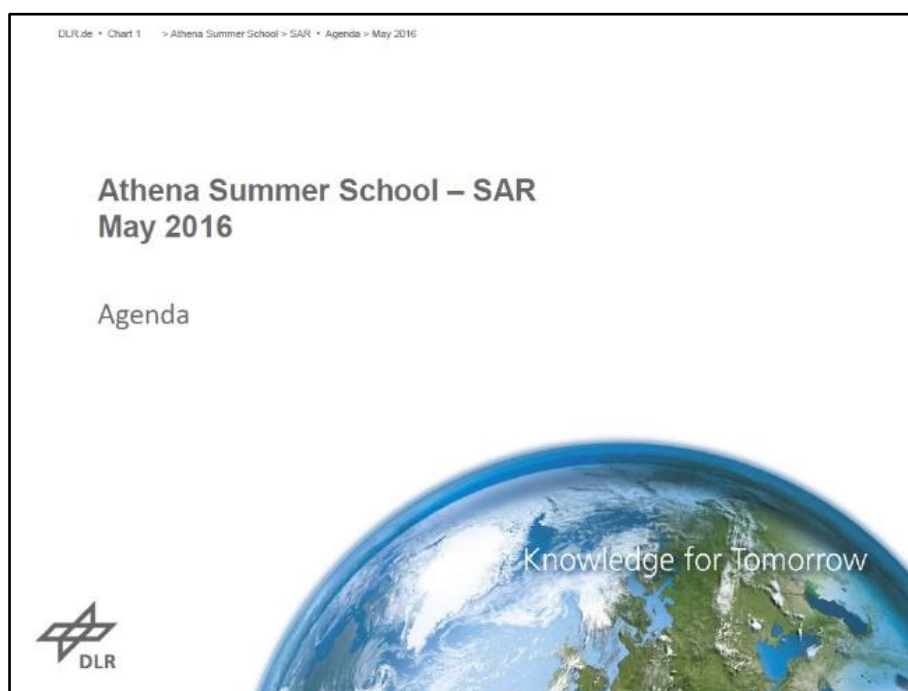

DLR.de • Chart 2 • Athena Summer School • SAR • Agenda • May 2016

Day 1 - Monday 23 May

- Morning 09:00 – 12:00
 - SAR Principles and Applications
- Afternoon 13:30 – 16:30
 - InSAR Principles, Methods and Applications



DLR.de • Chart 3 • Athena Summer School • SAR • Agenda • May 2016

Day 2 - Tuesday 24 May

- Morning 09:00 – 13:30
 - Archaeological testsite visit
- Afternoon 15:00 – 17:00
 - Depending on time and interest:
 - Access to SAR data
 - Overview of SAR/InSAR/PSI software packages
 - Uses of SAR in Archaeology



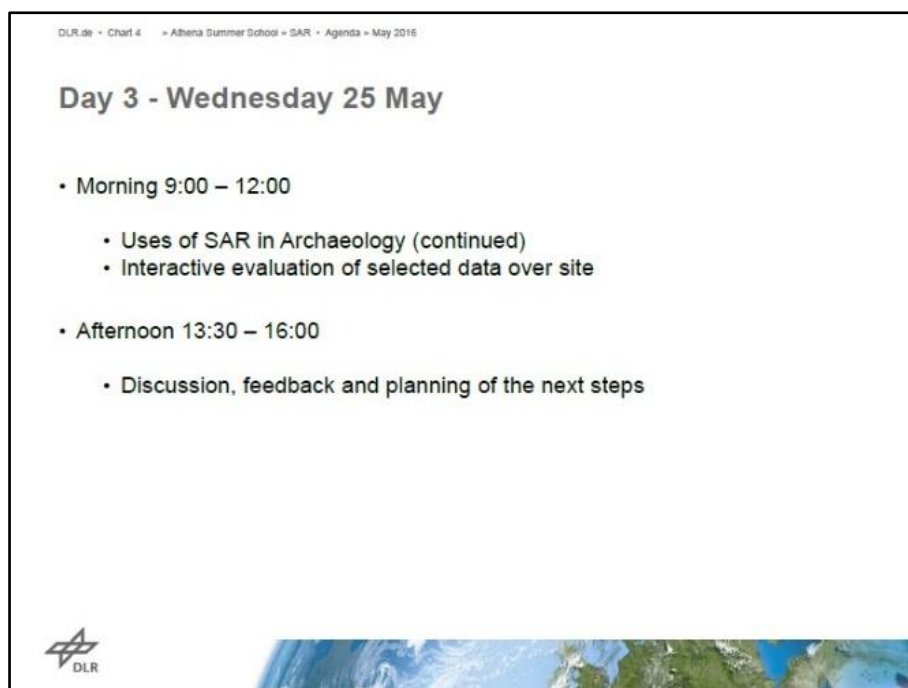

3. List of Participants

Contracted Researchers as well as permanent academic staff of the Cyprus University of Technology attended the summer school. The list of participants for each day is given below.

Monday, 23rd May 2016

	<p>H2020-TWINN-2015 - Remote Sensing Science Center for Cultural Heritage - A T H E N A 1st Summer School Topic: Interferometry/Radar Trainers: Ramon Bric & Michael Eineder (DLR) Monday, 23rd May, 2016 Cyprus University of Technology, Limassol - Cyprus</p>
---	--

List of participants

A/A	NAME	INSTITUTION	CONTACT DETAILS	SIGNATURE
1	Argyro Nisoutzi	CUT	argyro.nisoutzi@cut.ac.cy	
2	Athos Agapiou	-	athos.agapiou@cut.ac.cy	
3	Georgios Metillos	-	gmetillos@gmail.com	
4	KYRIAKOS THEMISTOCLEOUS	-	kt33@cyfamut.ac.cy	
5	KYRIAKOS NEOCLEOUS	CUT	kyriakos.neocleous@cut.ac.cy	
6	Christina Papoutsis	CUT	christina.papoutsis@cut.ac.cy	



This project has received funding from the European Union's Horizon 2020 research and innovation programme under grant agreement No 691936

7	MARIOS TZOUVEAS	CUT	marios.tzouveas@cut.ac.cy	
8	Andreas Christofe	CUT	andreas.christofe@cut.ac.cy	
9	Chris Daxeris	CUT	Chris.daxeris@cut.ac.cy	
10	Franky Lou	CUT	franky.lou@cut.ac.cy	
11	Vasiliki Iyسانχροου	CUT	vasiliki.lysanthroou@cut.ac.cy	
12	Ramon Bric	DLR	ramon.bric@dlr.de	
13	Dimitris HADJIARISI	CUT	d.hadjiarisi@cut.ac.cy	
14	Rodolise Mpanouri	CUT	rodolise.mpanouri@cut.ac.cy	
15	Christodoulos Mpanouris	CUT	Christodoulos.mpanouris@cut.ac.cy	
16	Michael Eineder	DLR - INF	Michael.Eineder@dlr.de	
17				







This project has received funding from the European Union's Horizon 2020 research and innovation programme under grant agreement No 691936

Tuesday, 24th May 2016

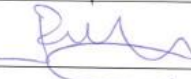
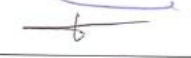
   	<p>H2020-TWINN-2015 - Remote Sensing Science Center for Cultural Heritage - A T H E N A 1st Summer School Topic: Interferometry/Radar Trainers: Ramon Brcic & Michael Eineder (DLR) Tuesday, 24th May, 2016 Cyprus University of Technology, Limassol - Cyprus</p>
--	---

List of participants

A/A	NAME	INSTITUTION	CONTACT DETAILS	SIGNATURE
1	Argyro Nisoutzi	CUT	argyro.nisoutzi@cut.a.cy	
2	Rodanthi MAMOURI	CUT	rodanthi.mamouri@cut.ac.cy	
3	Athos Agapiou	CUT	athos.agapiou@cut.ac.cy	
4	KYRIAKOS NEOCLEOUS	CUT	kyriakos.neocleous@cut.ac.cy	
5	VASILIKI LYSANDROU	CUT	vasiliki.lysandrou@cut.ac.cy	
6	KYRIAKOS THEMISTOCLEOUS	CUT	kt33@cut.ac.cy	

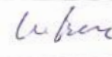

This project has received funding from the European Union's Horizon 2020 research and innovation programme under grant agreement No 691936

7	Michael Eineder	DLR	Michael.Eineder@dlr.de	
8	Christiane Papoutsou	CUT	christiane.papoutsou@cut.ac.cy	
9	Ramon Brcic	DLR	ramon.brcic@dlr.de	
10				
11				
12				
13				
14				
15				
16				
17				









This project has received funding from the European Union's Horizon 2020 research and innovation programme under grant agreement No 691936

Wednesday, 25th May 2016





   	<p>H2020-TWINN-2015 - Remote Sensing Science Center for Cultural Heritage - A T H E N A 1st Summer School Topic: Interferometry/Radar Trainers: Ramon Bric & Michael Eineder (DLR) Wednesday, 25th May, 2016 Cyprus University of Technology, Limassol - Cyprus</p>
--	--

List of participants

A/A	NAME	INSTITUTION	CONTACT DETAILS	SIGNATURE
1	Argyro Nisantzi	CUT	argyro.nisantzi@cut.ac.cy	
2	ΚΡΙΑΚΩΛ (DEMISTREAS)	CUT	ktas@cut.ac.cy	
3	ΜΑΡΙΟΣ ΤΡΟΥΒΑΡΑΣ	CUT	marios.trouvaras@cut.ac.cy	
4	Michael Eineder	DLR	Michael.Eineder@dlr.de	
5	Branke Cuce	CUT	branke.cuce@cut.ac.cy	
6	Κρησός Κωνσταντίνος	CUT	kyriacos.konstantinos@cut.ac.cy	

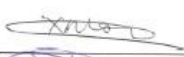

This project has received funding from the European Union's Horizon 2020 research and innovation programme under grant agreement No 691936

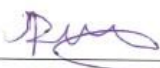
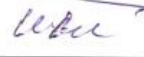
7	Athos Agapita	CUT	athos.agapita@cut.ac.cy	
8	Vasiliki Lysandrou	CUT	vasiliki.lysandrou@cut.ac.cy	
9	Christiana Papoutsis	CUT	christiana.papoutsis@cut.ac.cy	
10	Aris Dedeziis	CUT	aris.dedeziis@cut.ac.cy	
11	Rodanthi Mousari	CUT	rodanthi.mousari@cut.ac.cy	
12	Roman Bric	DLR	roman.bric@dlr.de	
13				
14				
15				
16				
17				



This project has received funding from the European Union's Horizon 2020 research and innovation programme under grant agreement No 691936

4. Presentations during the summer school

All presentations of the Summer School are given in the Annex of the Deliverable, in the following order

- 4.1 SAR Principle and Application
- 4.2 SAR Interferometry-Basics
- 4.3 SAR Interferometry-Error_Sources
- 4.4 Software
- 4.5 SAR Data Availability for PaphosTestsite
- 4.6 Data Evaluation

5. Pictures from the 1st Summer School



Participants of the ATHENA SAR Summer School during the first day training in the Eratosthenis Research Center



Participants of the ATHENA SAR Summer School during the first day training in the Eratosthenis Research Center



ATHENA SAR Summer School participants visiting the Archaeological site of NeaPaphos.



ATHENA SAR Summer School participants guided by Dr. E. Charalambous (chief mosaic conservator, Department of Antiquities of Cyprus) in the mosaics' laboratory.



ATHENA SAR Summer School participants examining a mosaic in the 'House of Dionysus', NeaPaphos.



Participants of the ATHENA SAR Summer School in the newly outfitted ATHENA Lab located in the Eratosthenis Research Center

ANNEX

PRESENTATIONS OF THE SUMMER SCHOOL

Earth Observation Center



Staff: 250/130 (DFD/IMF)



Technische Universität München



Remote Sensing Technology Institute (IMF)

Director: Richard Bamler

German Remote Sensing Data Center (DFD)

Director: Stefan Dech



Remote Sensing Technology Institute

EO Technologies and Competences

Synthetic Aperture Radar (SAR)

- Processors for TerraSAR-X, TanDEM-X, PAZ, Tandem-L, etc.
- Imaging geodesy
- 4D imaging: PSI, SAR tomography et al.
- SAR oceanography, maritime security

Optical Imaging

- Processors for EnMAP and DESIS
- CATENA: generic processing chain for 15+ sensors
- 3D: dense stereo matching and object reconstruction, computer vision
- Hyperspectral methods: retrieval, unmixing, classification, fusion
- Ocean color, water quality
- Calibration Home Base and airborne systems

Atmospheric Spectrometry and Lidar

- Processors for GOME-2, ADM, MERLIN, Sentinel 5p/4/5, etc.
- Spectrometry laboratory
- Scattering theory, radiative transfer, inversion methods

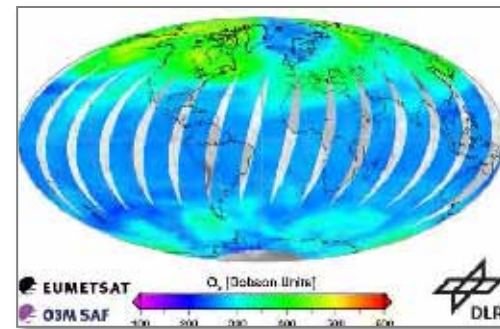
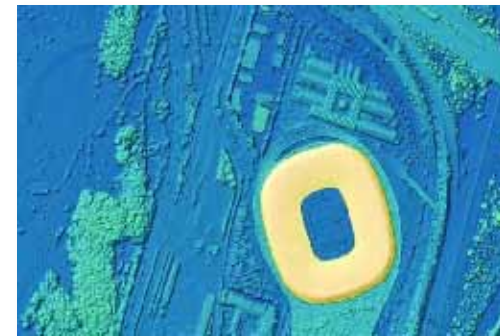
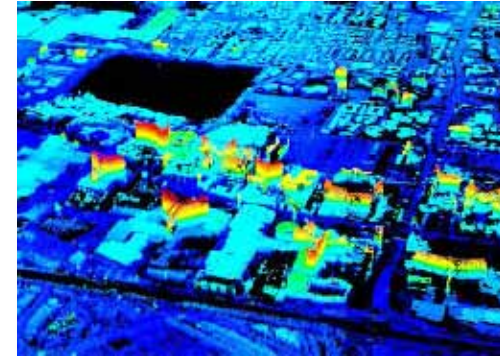

Athena Summer School – SAR
Cyprus University of Technology, Lemesos May 2016

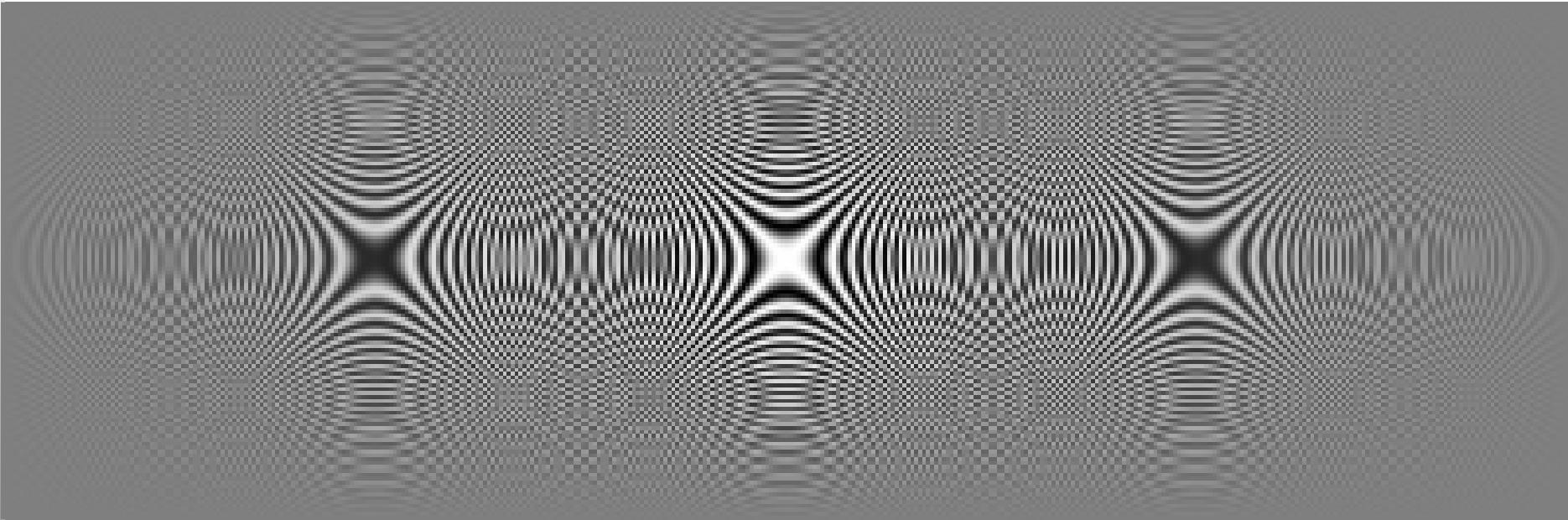

Part 1: Synthetic Aperture Radar (SAR) Principles

Prof. Dr. Michael Eineder (DLR/TUM)

Synthetic Aperture Radar (SAR)

1 Introduction

2 Range Imaging

3 Formation of Synthetic Aperture (Azimuth-Component)

4 Characteristics of SAR Images

The German TerraSAR-X Satellite (Launch 2007)

Wet mass: 1209 kg
Orbit average power: 800 W
Size: 5 m height × 2.4 m diameter

Solar Generator

Thrusters

X-Band Phased-Array
Radar Antenna (*steerable +/-2.2°*)
384 Transmit/Receive Modules

S-Band TM/TC Antenna

X-Band Downlink Antenna
Data Rate: 300 MBit/sec
256 Gbit Solid State Mass Memory

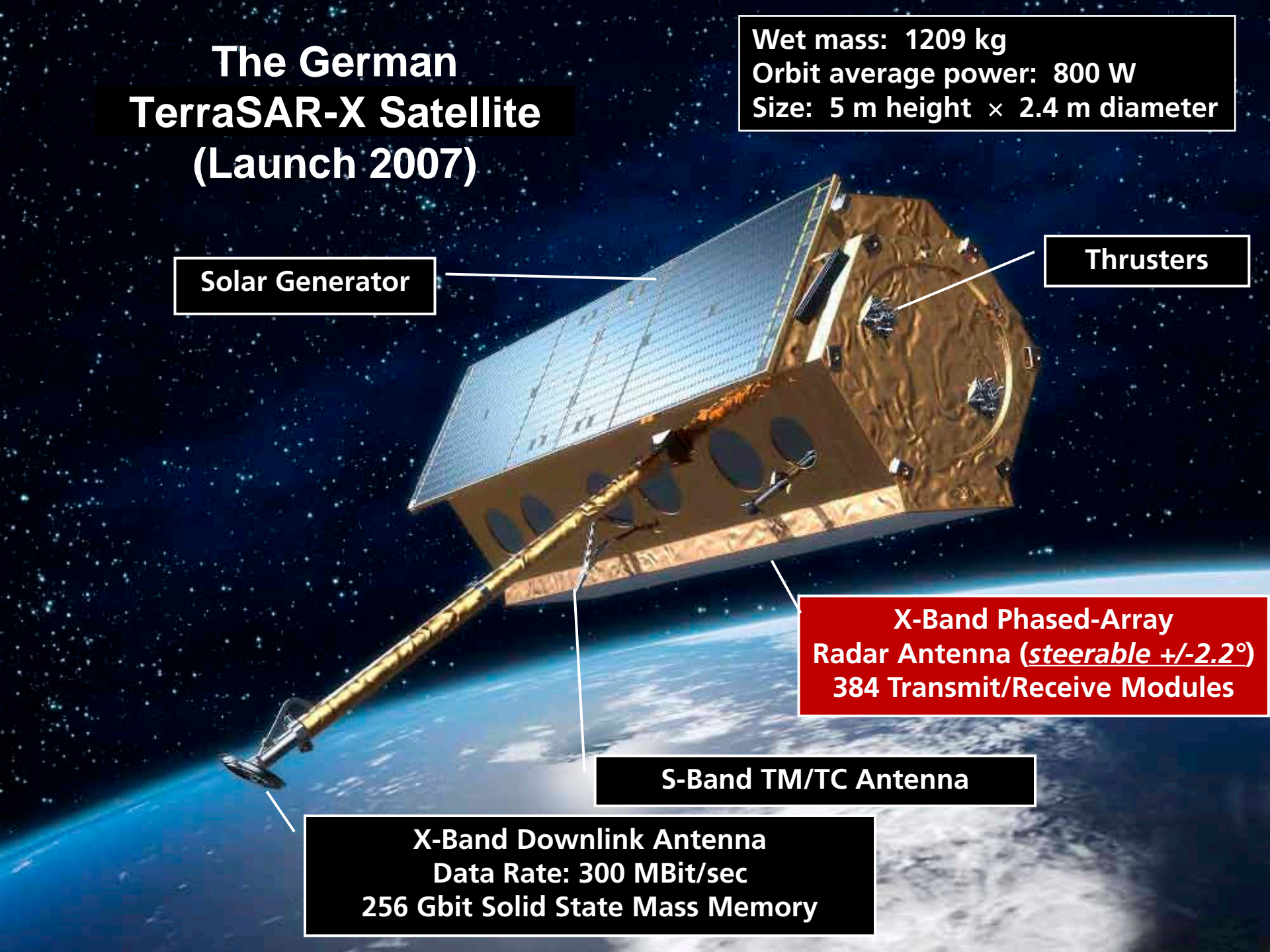



**SAR Image of
the Ocean
Tenerife,
Canary Islands**

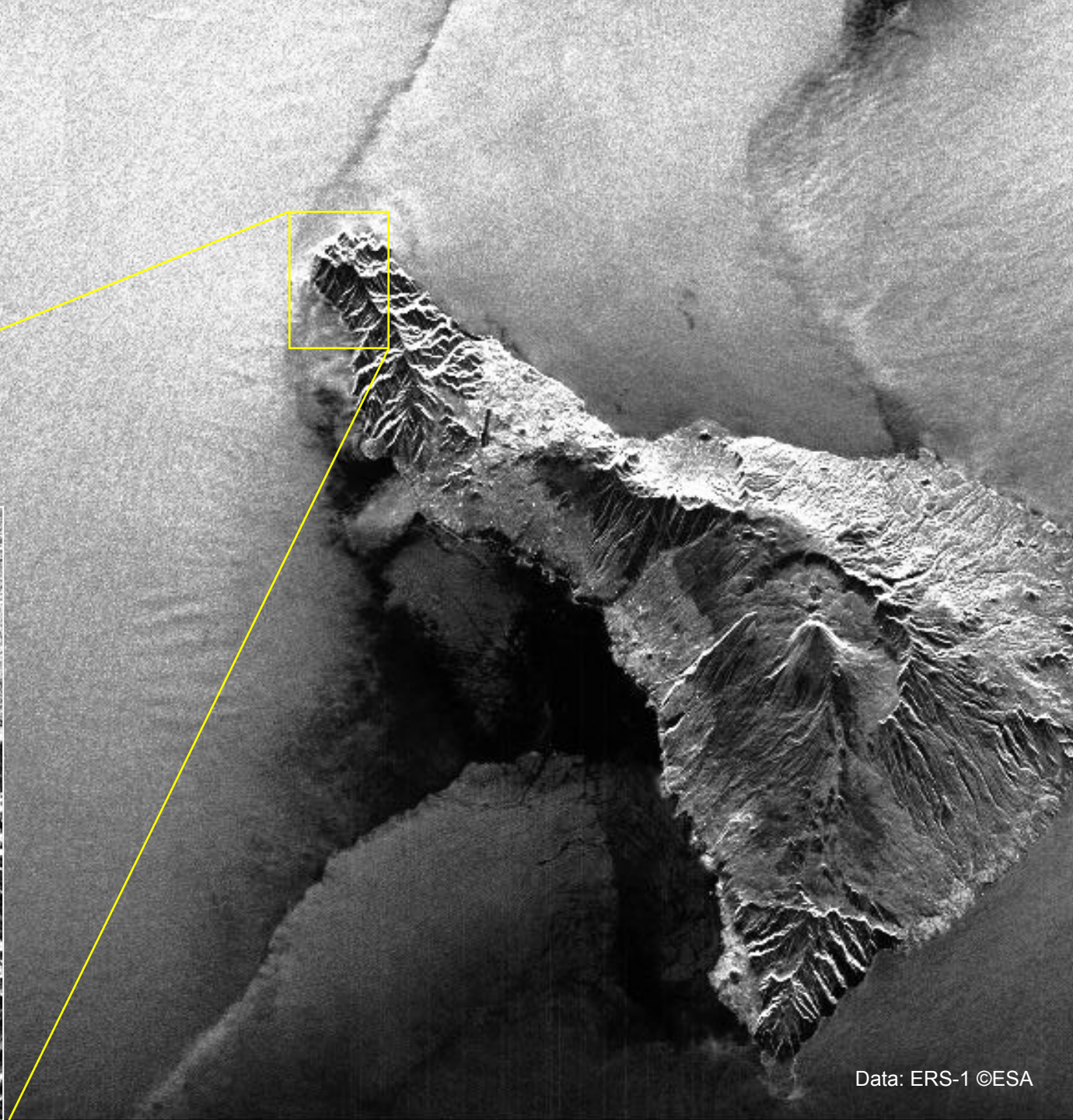
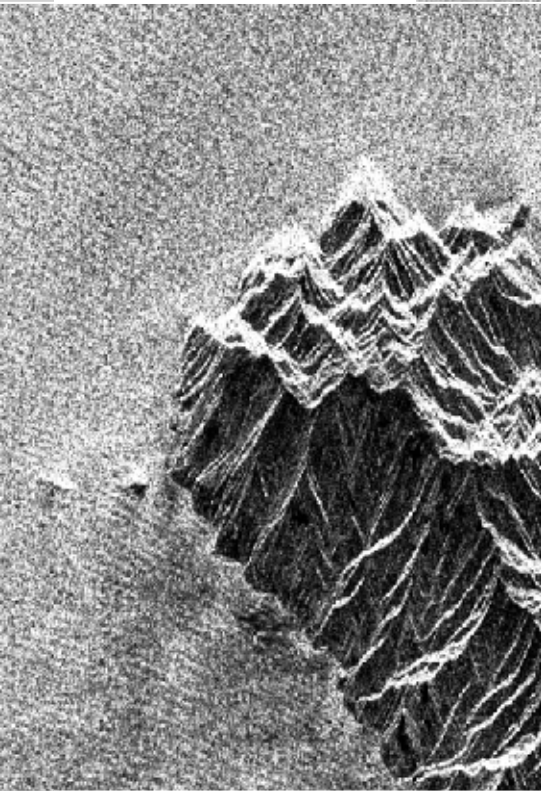

ScanSAR



Stripmap



← 7 km →

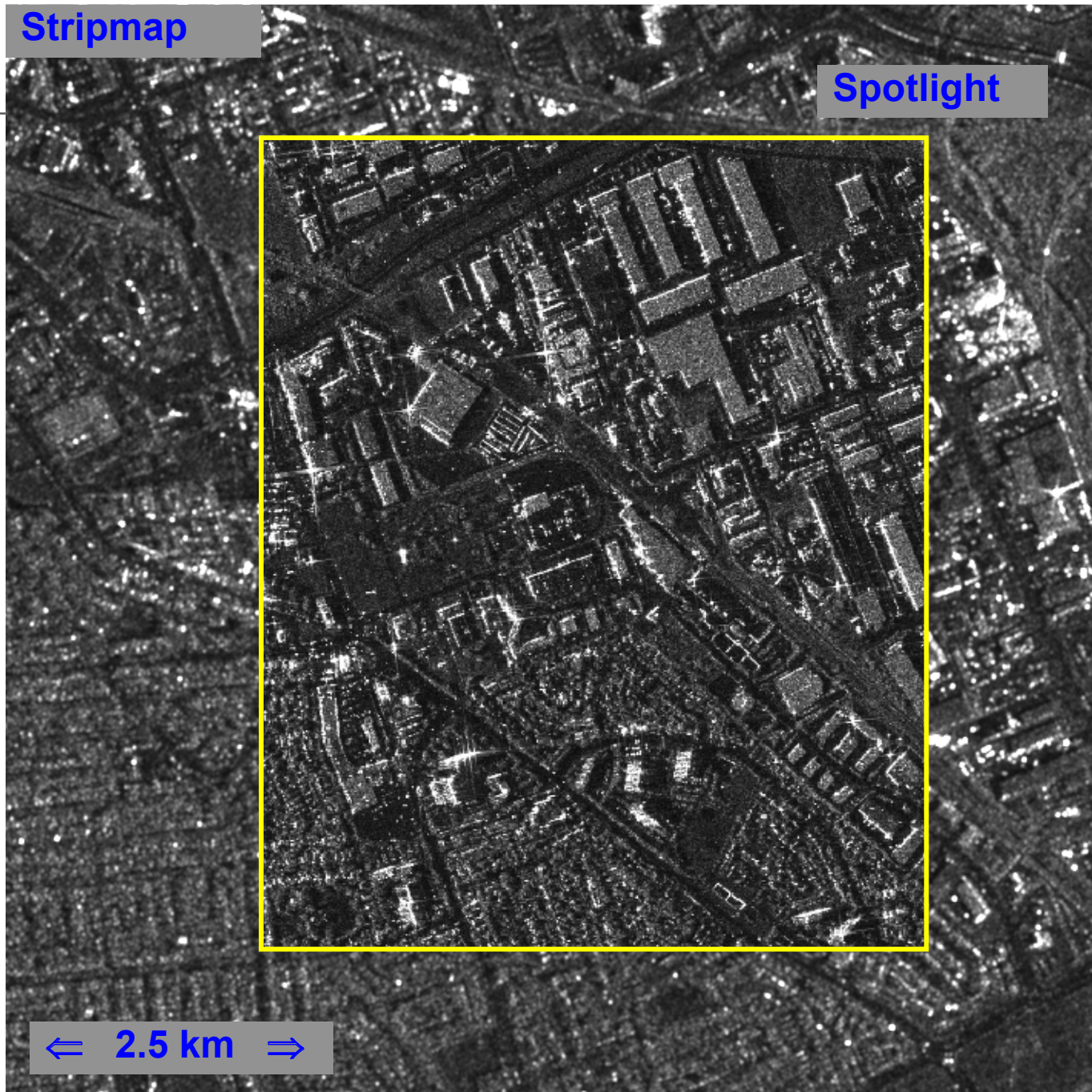

- Microwave imaging is powerful and reliable, because it works at night and under bad weather conditions
- But aperture dependent diffraction angle limits the resolution of sensors and transmitters (e.g. antennas)

$$\alpha = \lambda / D$$

- Examples:

Human eye:

$$1000 \text{ km} * 500 \text{ nm} / 5 \text{ mm} = 100 \text{ m}$$

Satellite dish antenna (Ku-Band):

$$1000 \text{ km} * 2 \text{ cm} / 60 \text{ cm} = 33 \text{ km} (!)$$

- → we need to solve this problem because the real (physical) antenna is too small for the desired resolution ...

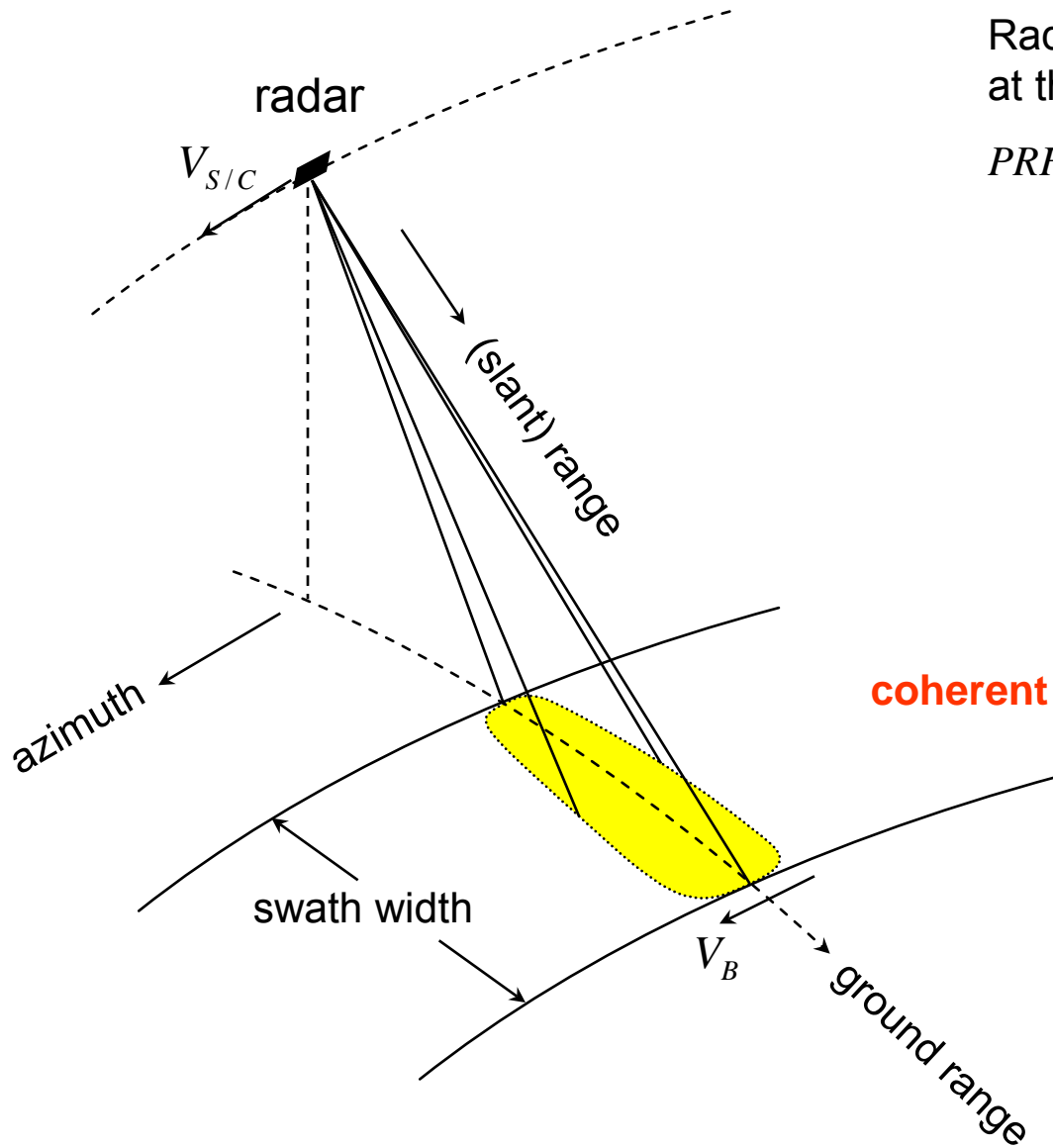

Radar transmits pulses and receives echoes at the rate of the pulse repetition frequency:

$$PRF \cong 1000 - 4000 \text{ Hz}$$

range: radar principle = scanning at speed of light

azimuth: scanning in flight direction at V_B plus aperture synthesis (holography)

coherent imaging: complex-valued pixels contain amplitude (brightness) and **phase** information

for this lecture: straight flight path

$$\Rightarrow V_{S/C} = V_B = V$$

Synthetic Aperture Radar (SAR)

1 Introduction

2 Range Imaging

3 Formation of Synthetic Aperture (Azimuth-Component)

4 Characteristics of SAR Images

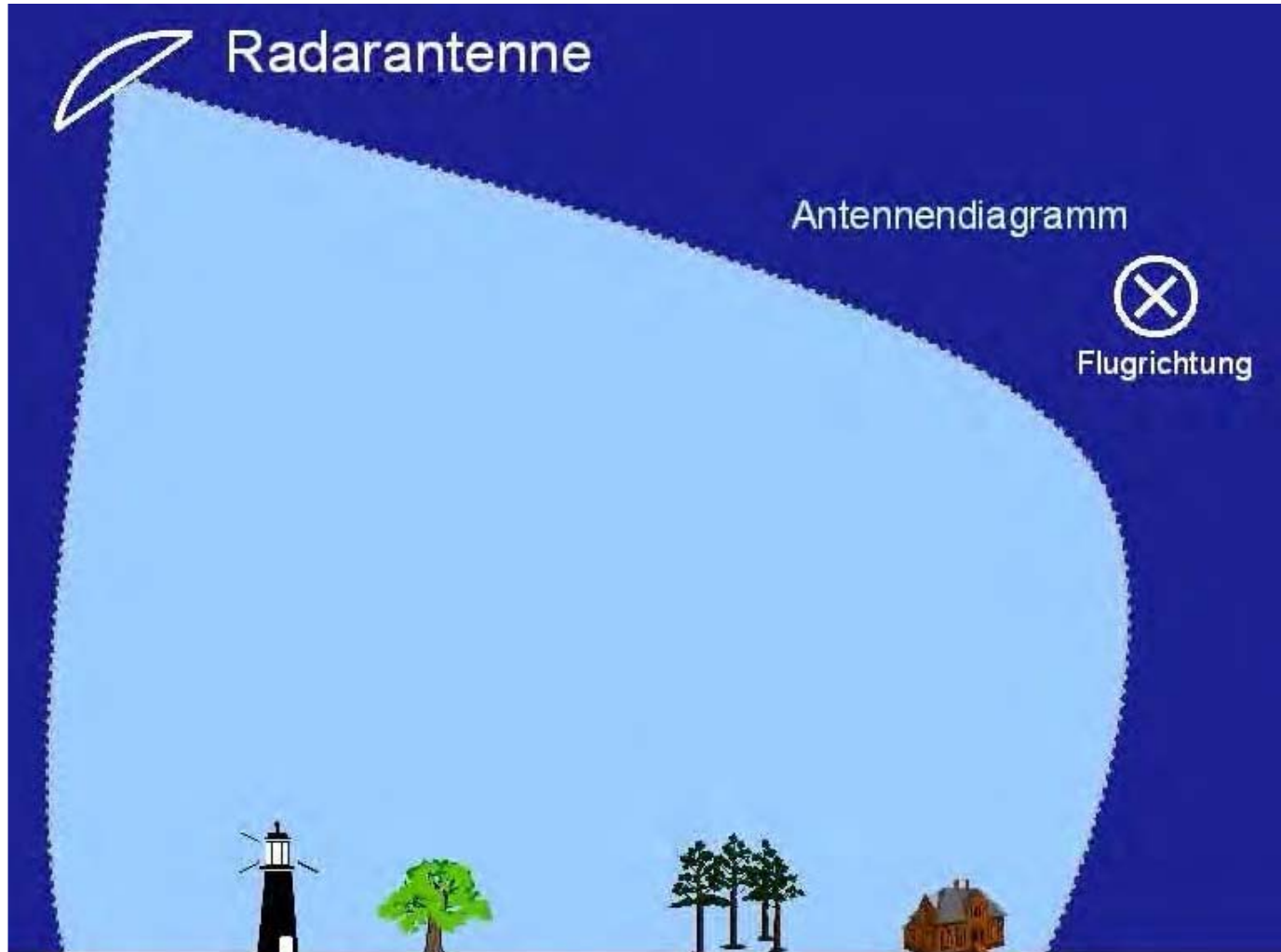

→ sampling and storing echoes of transmitted pulse

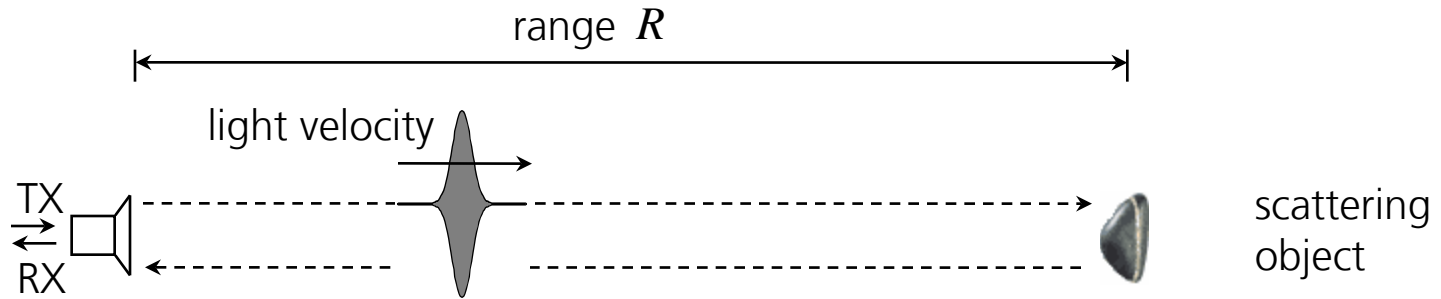

received echo:

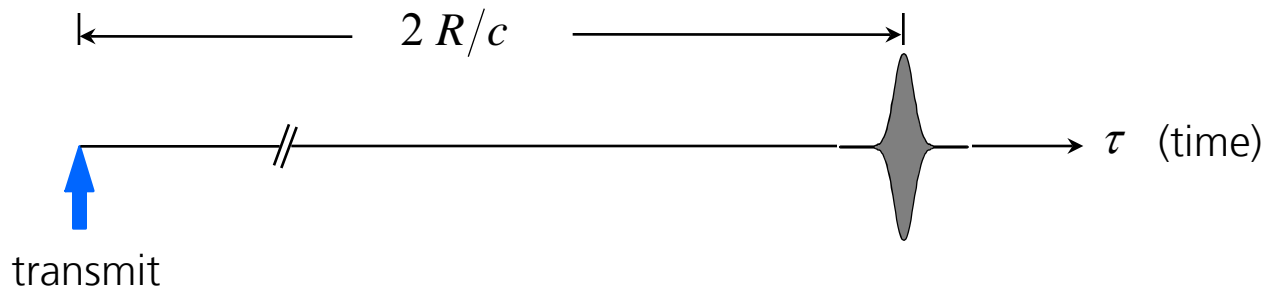

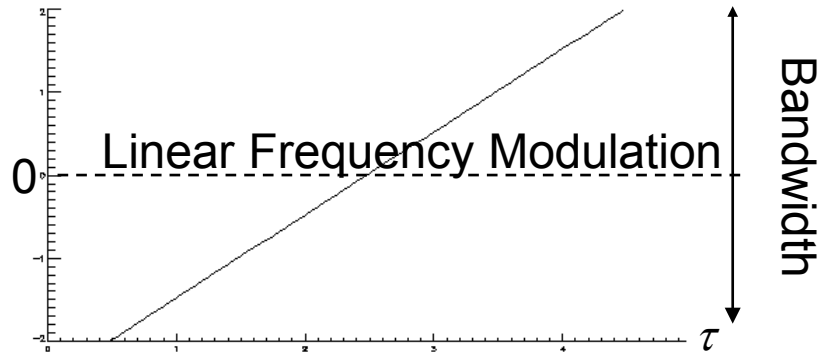
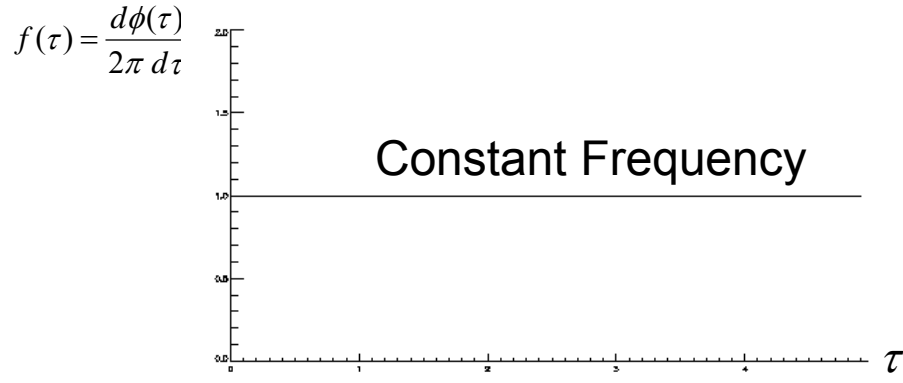
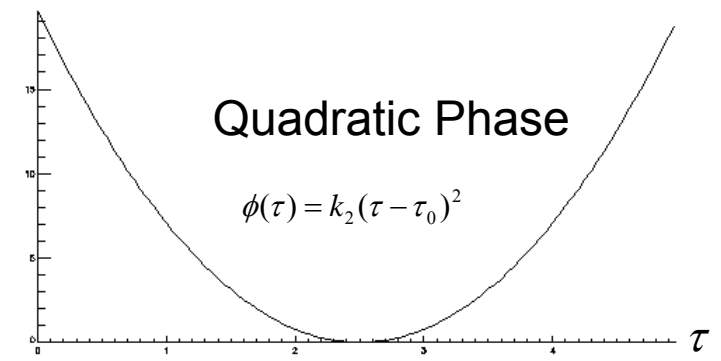
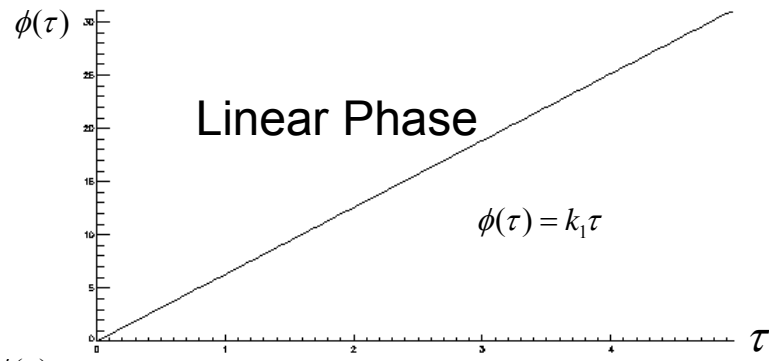
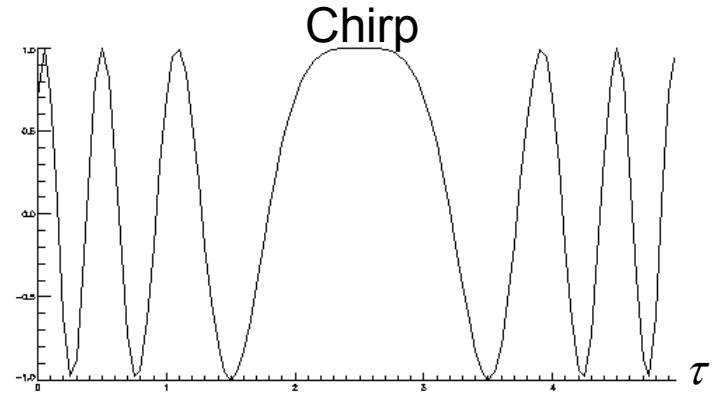
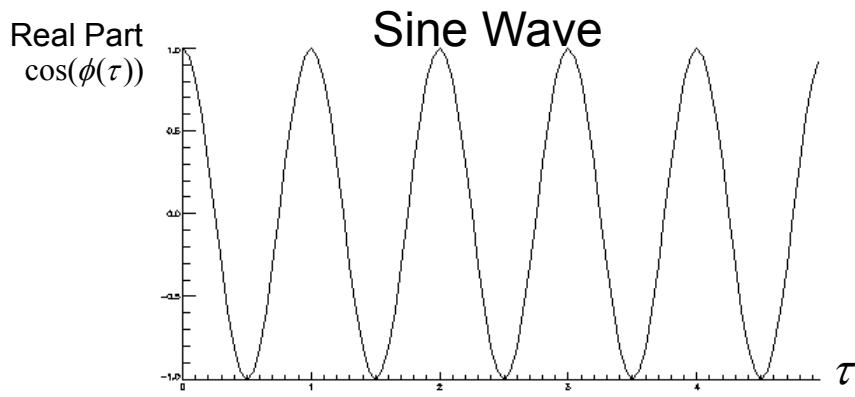

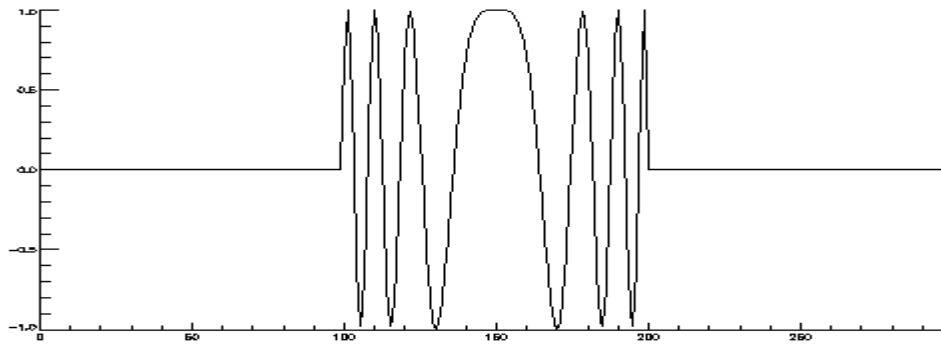

Signal transmitted from satellite
(=echo from every single pixel)

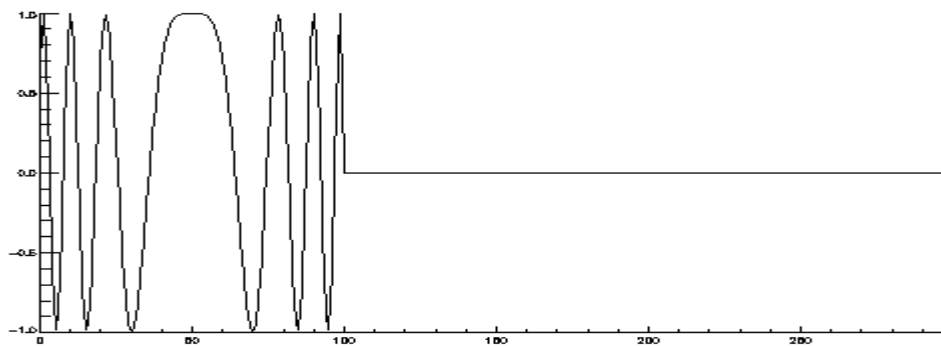

Reference chirp

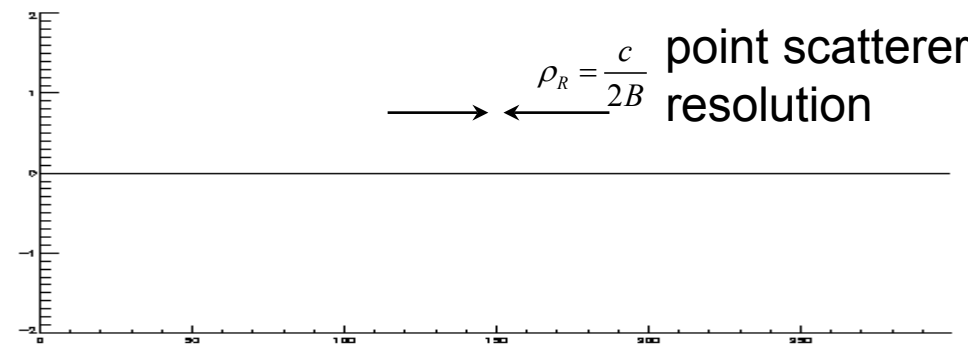

SAR processing
(range compression by matched filtering)

$$\text{Resolution: } \rho_R = \frac{c}{2 \cdot \text{Bandwidth}}$$

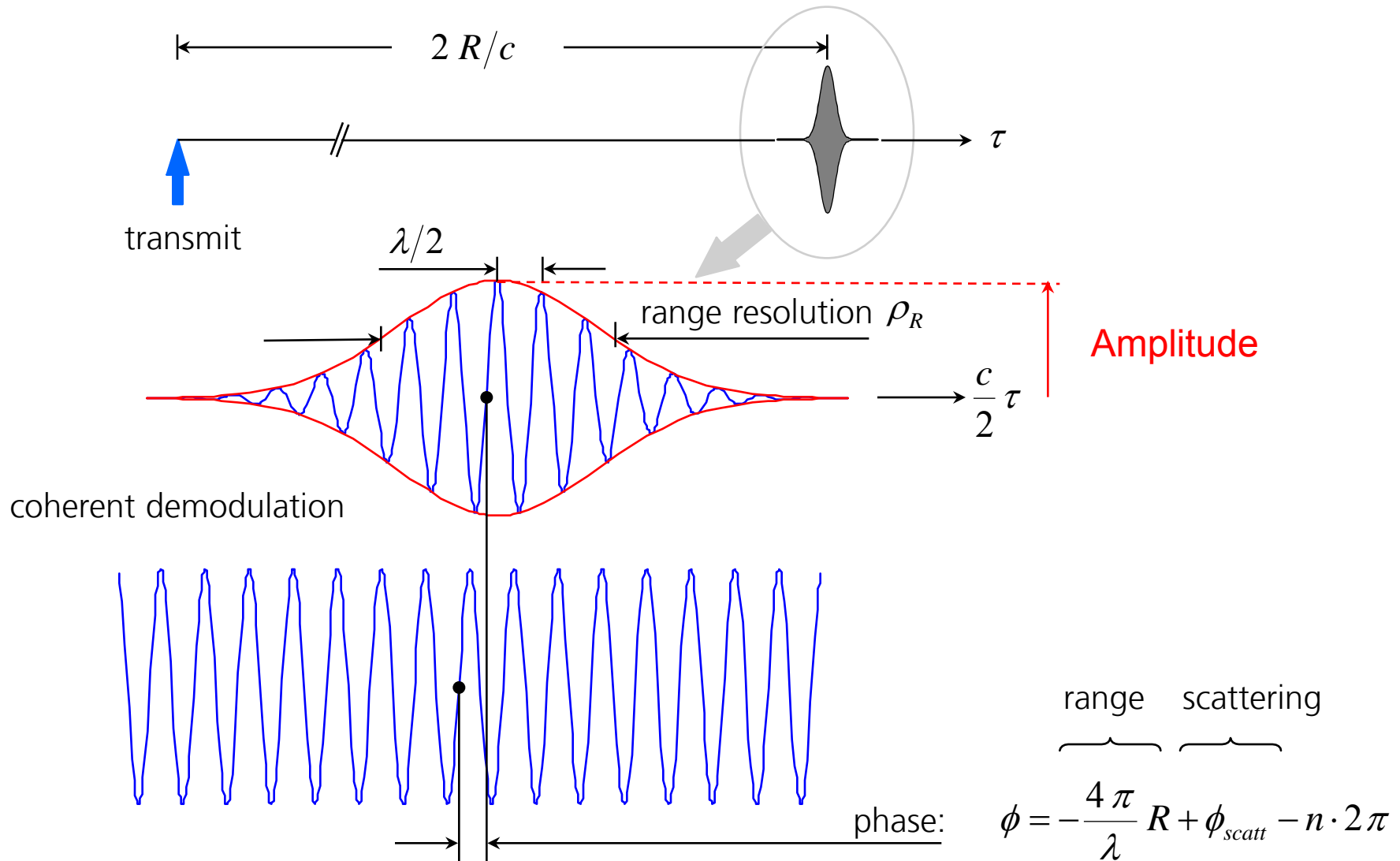

Synthetic Aperture Radar (SAR)

- 1 Introduction
- 2 Range Imaging
- 3 Formation of Synthetic Aperture (Azimuth-Component)**
- 4 Characteristics of SAR Images

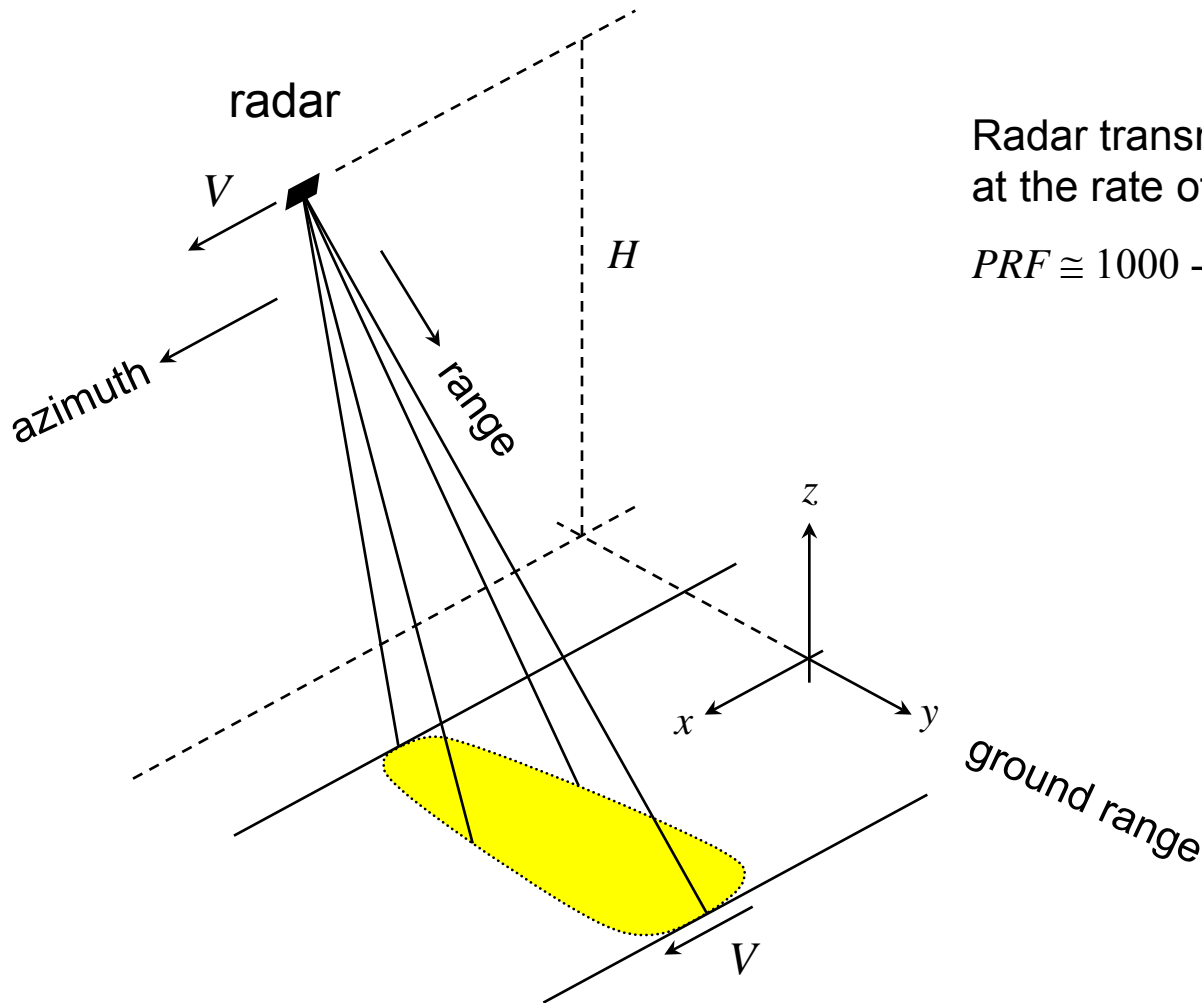

Radar transmits pulses and receives echoes at the rate of the pulse repetition frequency:

$$PRF \cong 1000 - 4000 \text{ Hz}$$

short antenna

wide beam

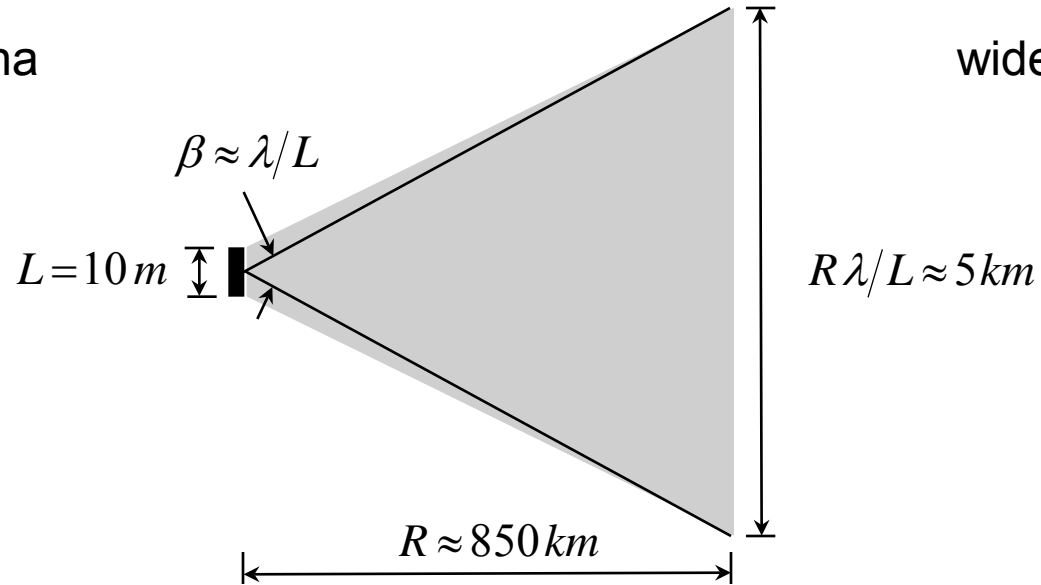

long antenna

narrow beam

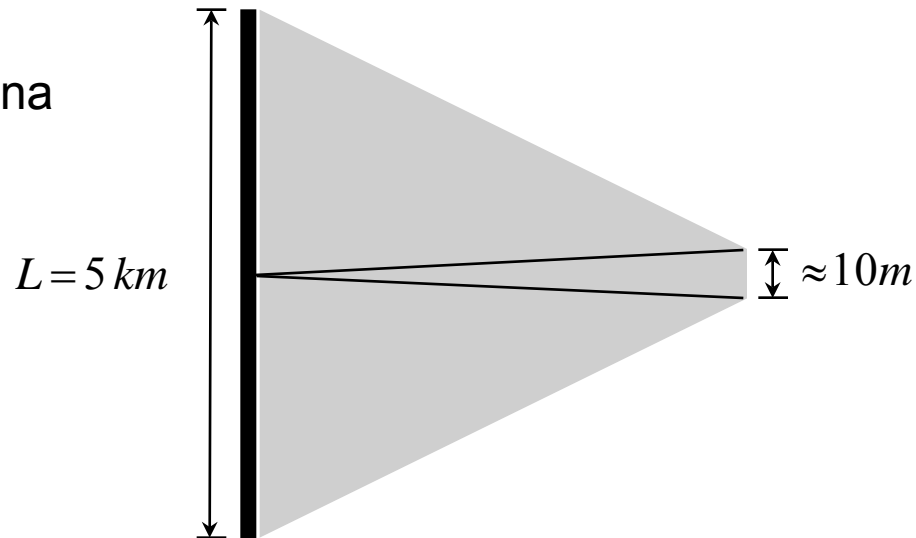

ERS-1/2 parameters

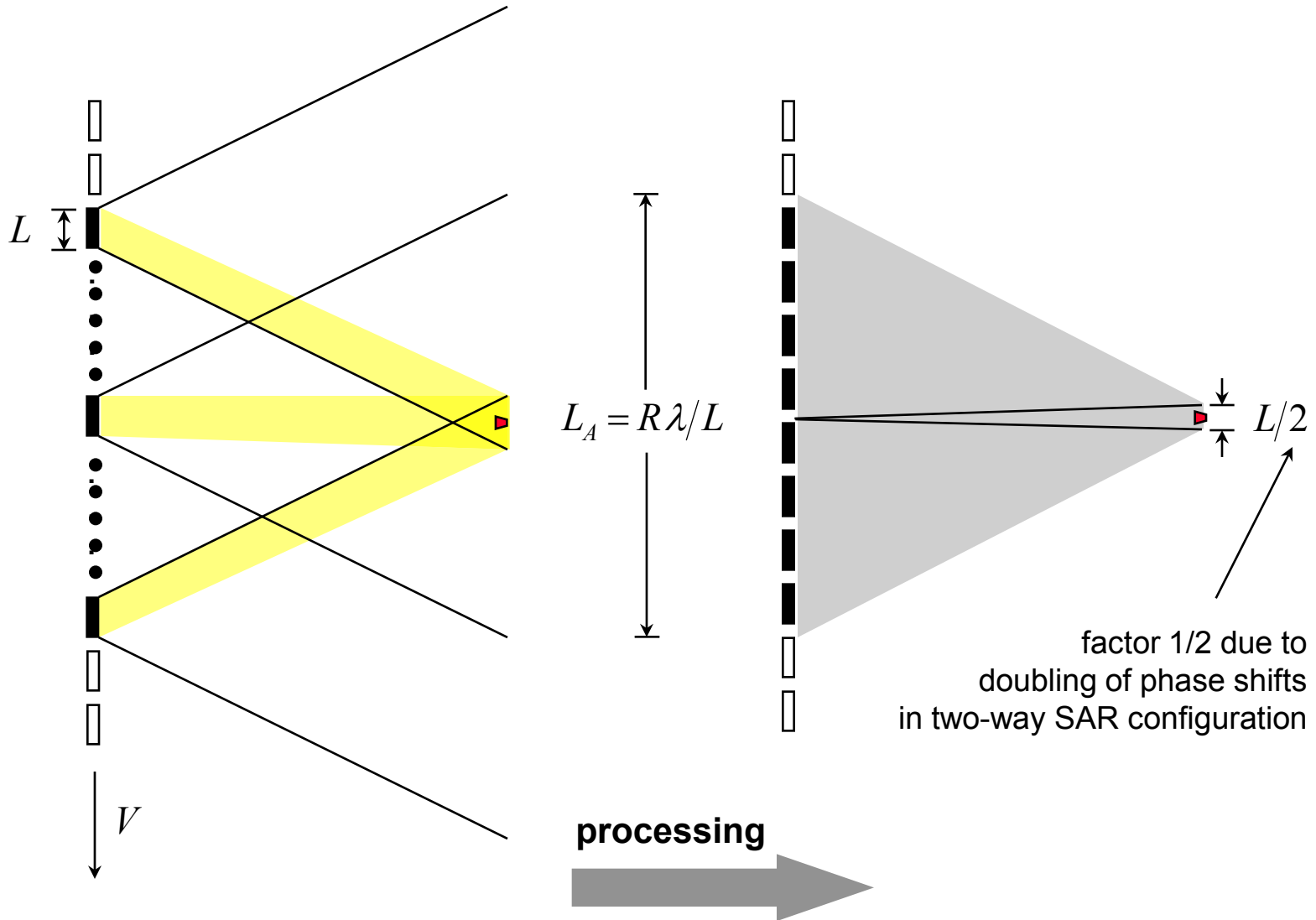

= phase corrected summation of echoes

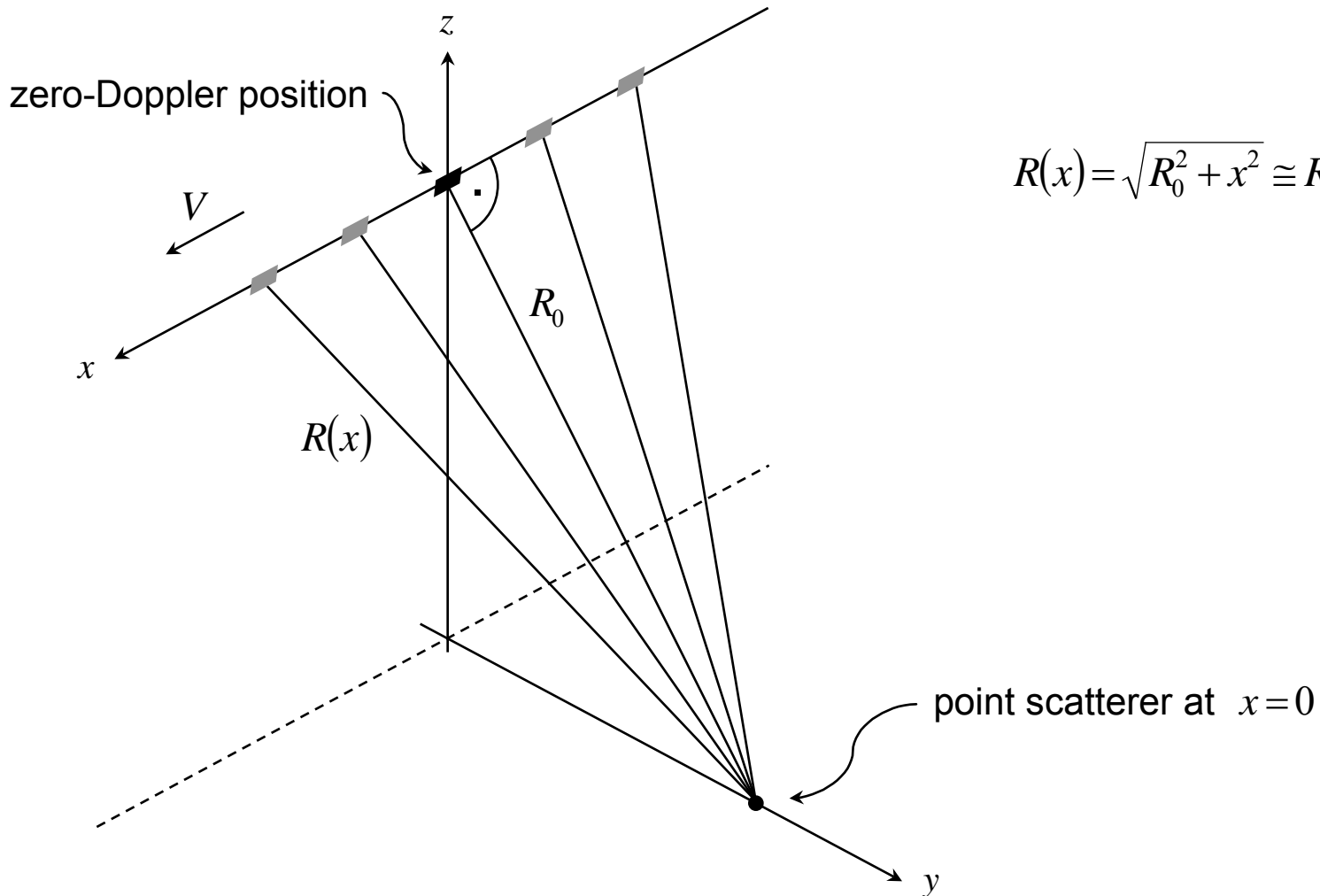

$$R(x) = \sqrt{R_0^2 + x^2} \cong R_0 + \frac{x^2}{2R_0}$$

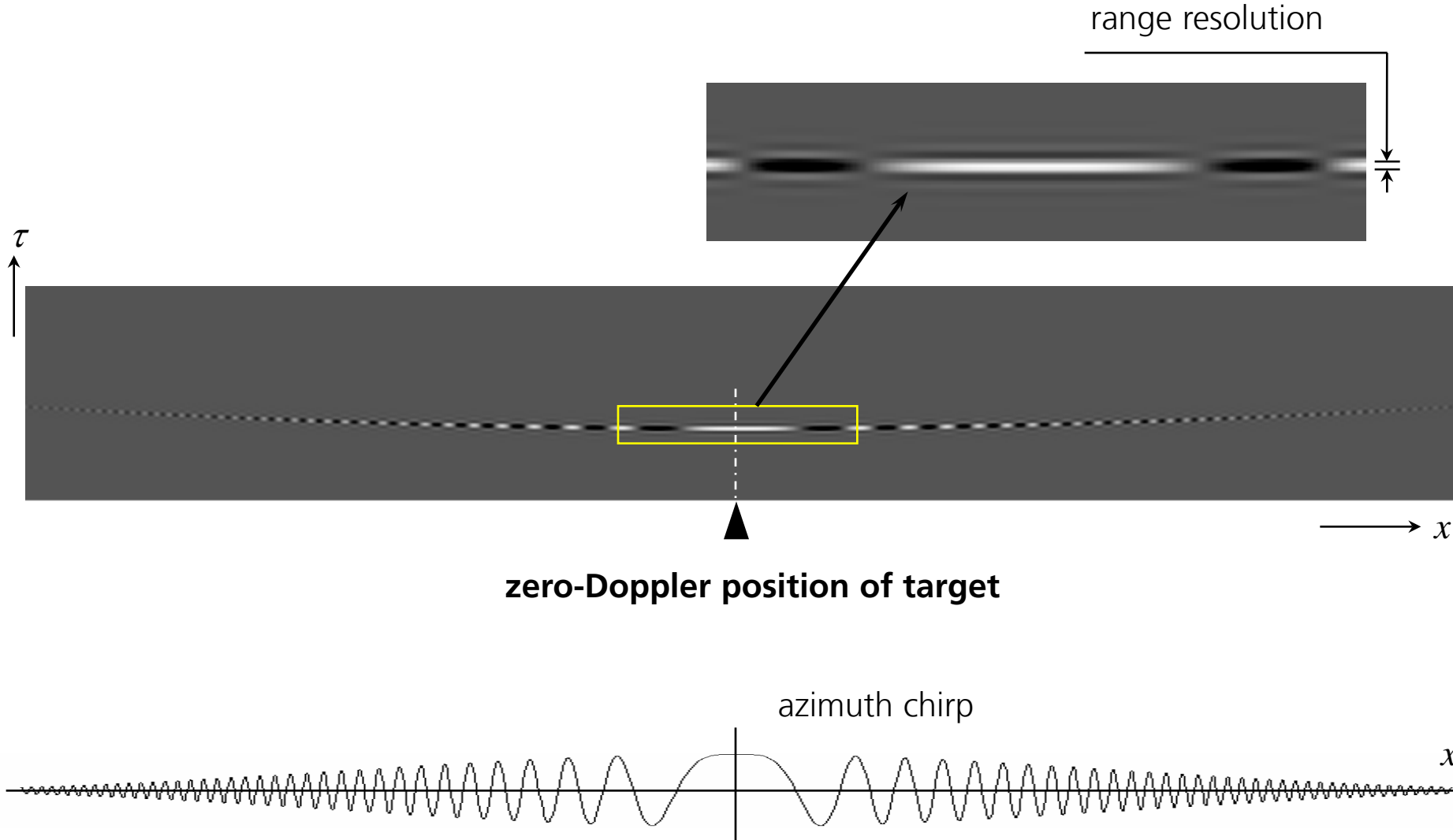

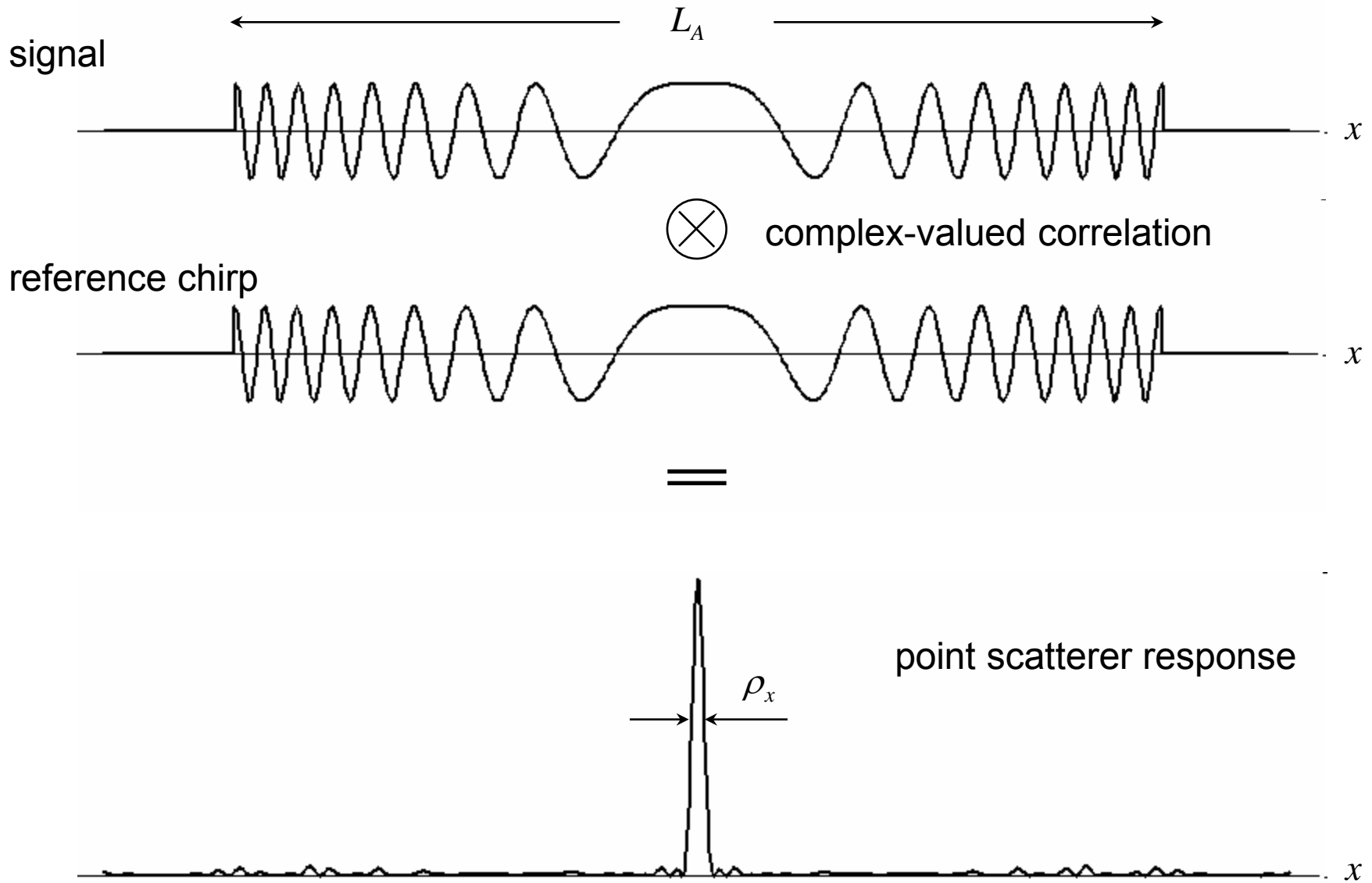

→ azimuth

data ERS-1 © ESA

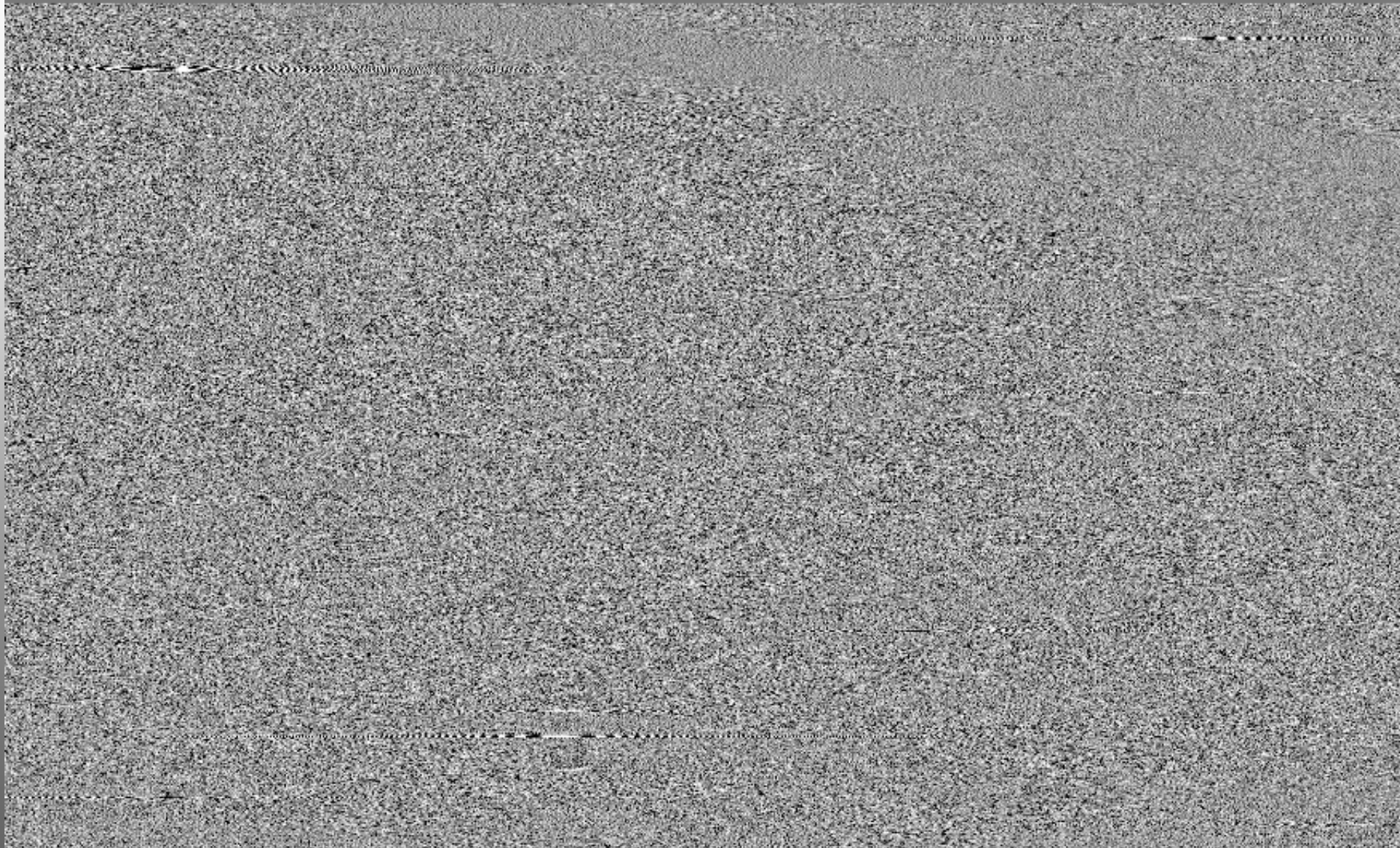

→ azimuth

data ERS-1 © ESA

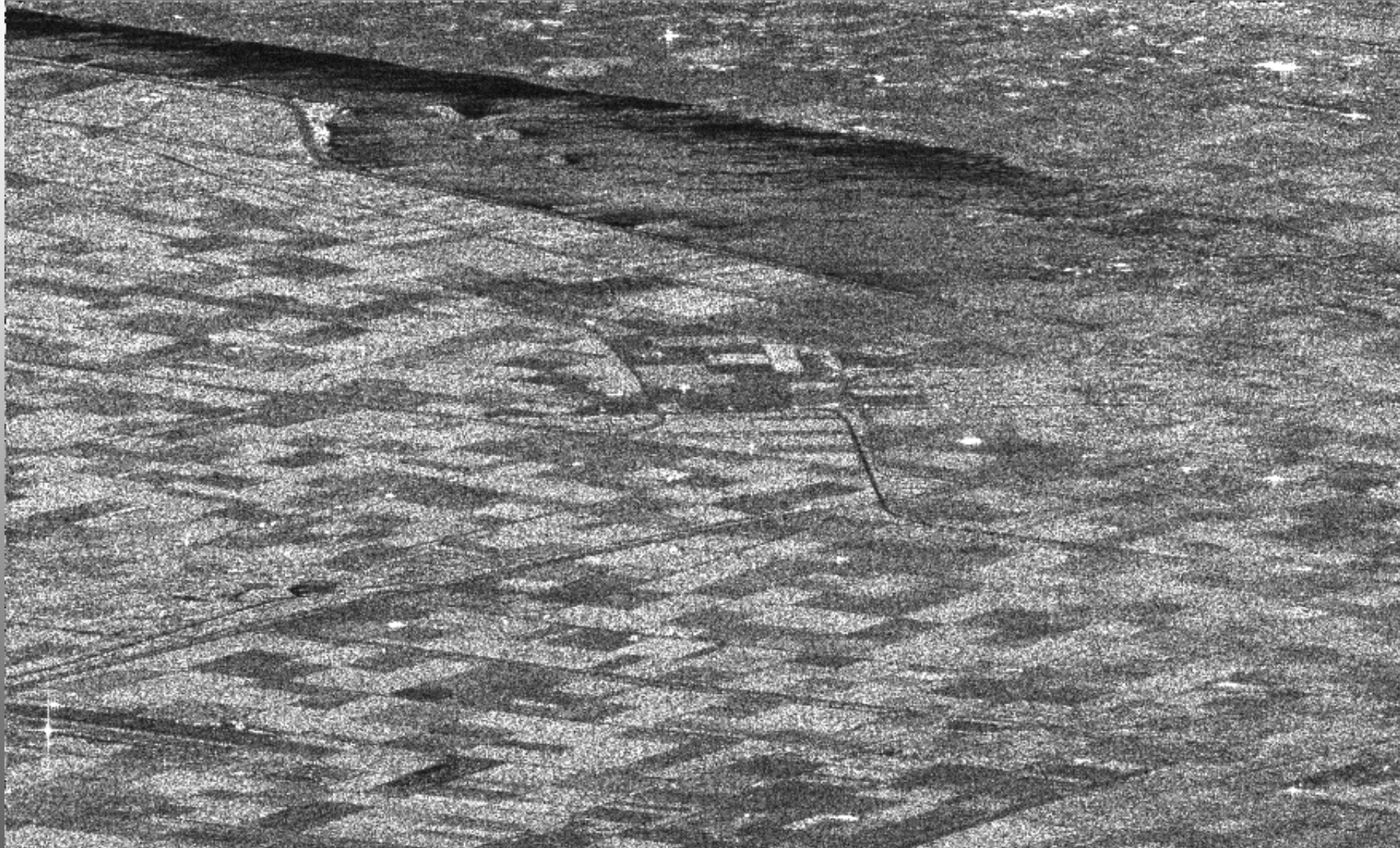

→ azimuth

after
azimuth pixel averaging by 4
to achieve approximately
square pixels



ScanSAR

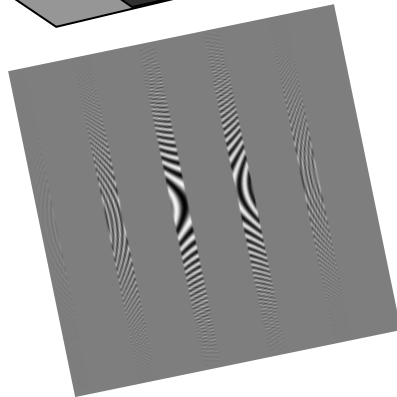
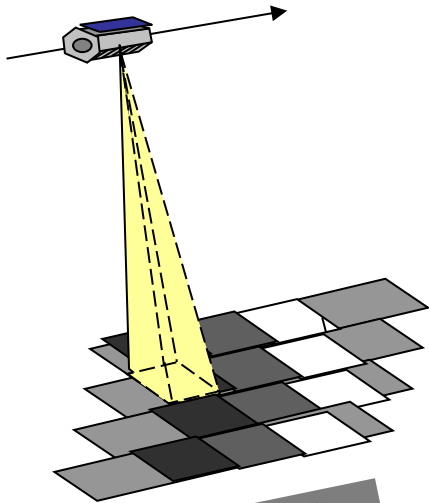

Wider swath
Lower resolution

Stripmap

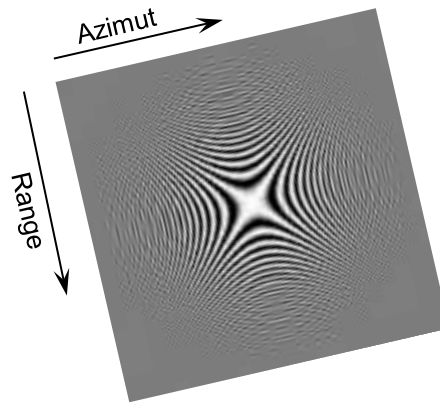
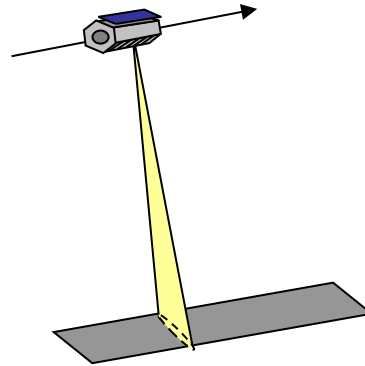

Spotlight

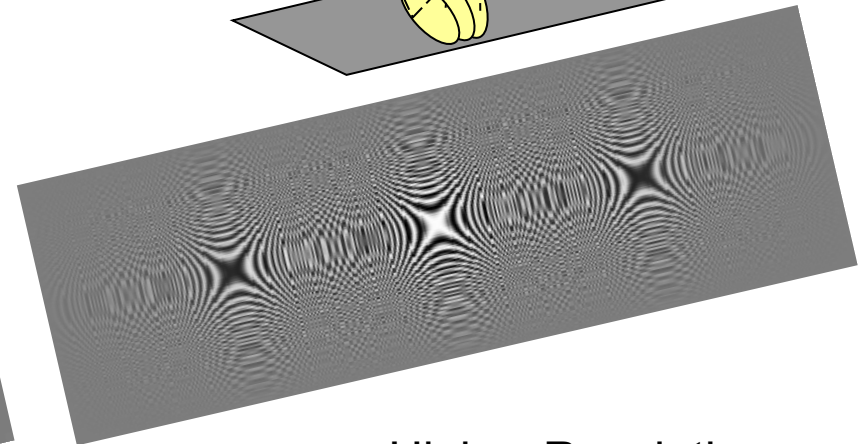
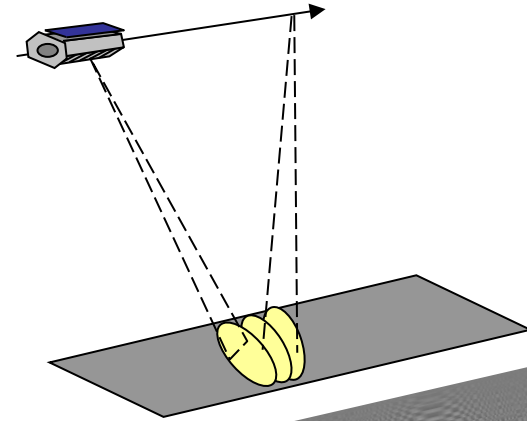

Higher Resolution
Smaller scene size



- Launch 2014, successor of ERS-1/2, Envisat
- Data freely available
- 12 day repeat (6 days with S1b)
- Standard mode: IW
Wide swath 250 km, 5x20 m resolution
- Stripmap swath 80 km, 5x9 m resolution

Intended for European Copernicus services:

- **Marine environment** (safety and transport, oil-spill, water quality, weather forecasting and polar environment)
- **Land environment** (water management, agriculture and food security, land-use change, forest monitoring, soil quality, urban planning and natural protection)
- **Emergency management** (floods, forest fires, earthquakes) and humanitarian aid exercises
- **Security** (peace-keeping efforts, maritime surveillance, border control)
- **Climate change**



Antarctica Peninsula from Sentinel-1A
Data © ESA

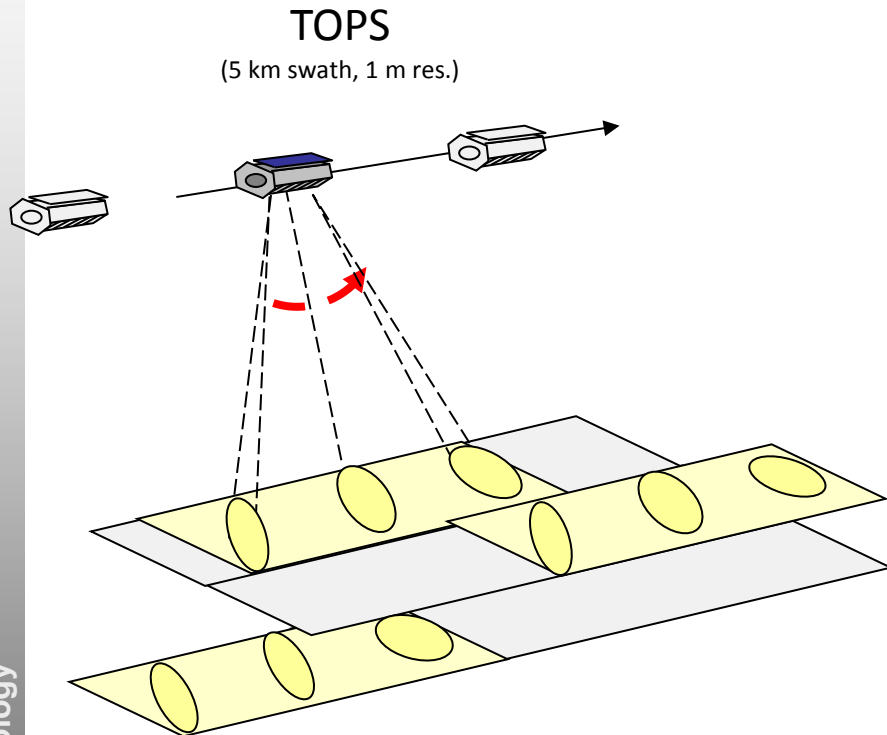

- Reduce aperture time by steering the antenna electronically **forward** in azimuth
- More azimuth distance, less illumination time per target
- Saved time can be used to electronically steer the antenna to other elevation directions

→ increased swath width (e.g. S1: 3 x = 250 km)

→ reduced resolution (e.g. S1: 17 m)

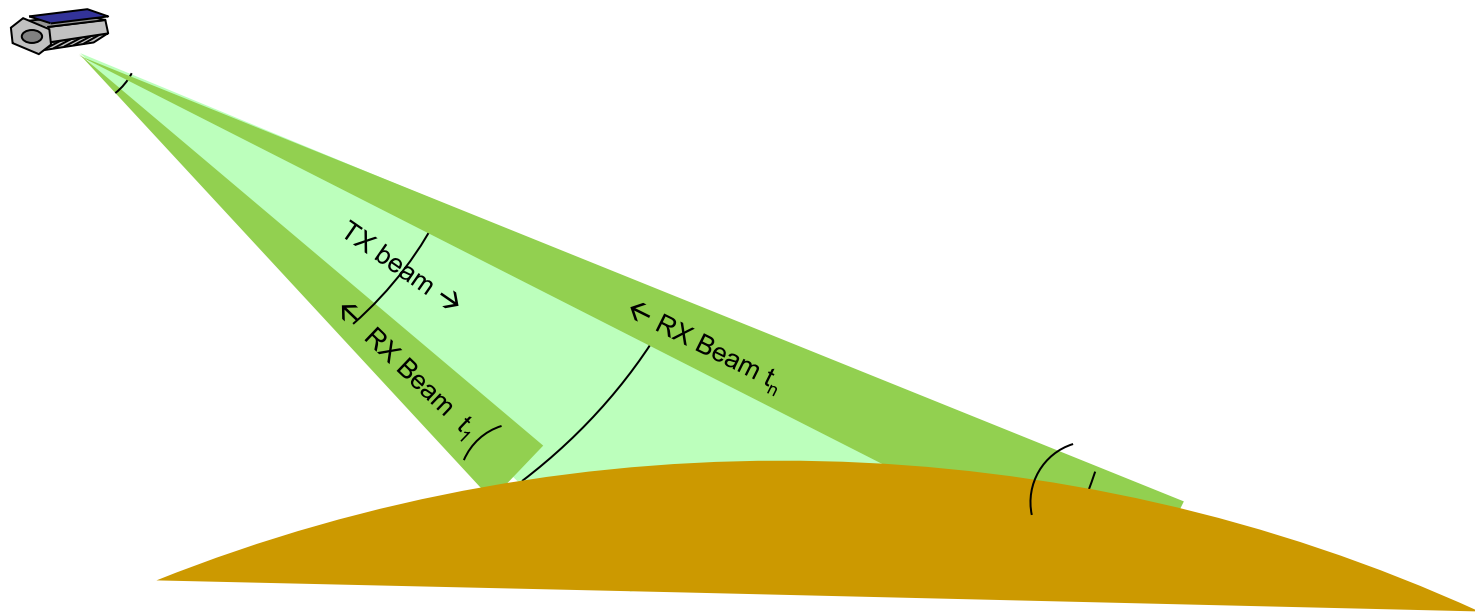

- Large transmit (TX) beam to illuminate wide swath with pulses
- Small receive (RX) beam to distinguish between echoes arriving simultaneously from consecutive pulses and from different directions
- Can therefore transmit with higher pulse rate and achieve higher azimuth resolution

Synthetic Aperture Radar (SAR)

- 1 Introduction
- 2 Range Imaging
- 3 Formation of Synthetic Aperture (Azimuth-Component)
- 4 Characteristics of SAR Images

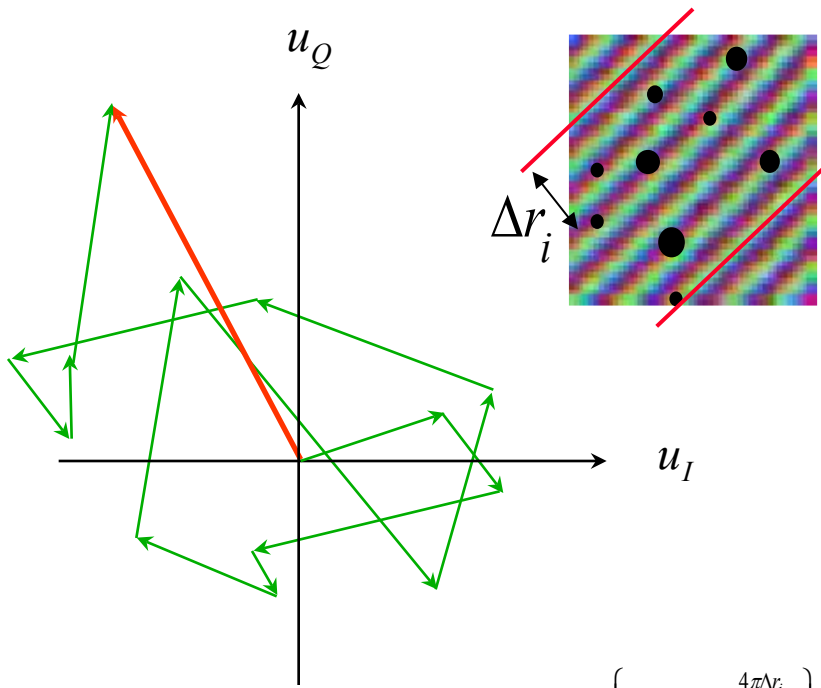

$$\phi_{scatt} = \arg \left\{ \sum A_i e^{-j \frac{4\pi \Delta r_i}{\lambda}} \right\}$$



ERS data © ESA

Random positive and negative interference of wave contributions from the many individual scatterers within one resolution cell

- varying brightness from pixel to pixel even for constant σ_0
- granular appearance

quantity →	magnitude $\sqrt{u_I^2 + u_Q^2}$	intensity $I = u_I^2 + u_Q^2$
probability distribution →	Rayleigh	exponential



$$pdf_I(I|\sigma^0) = \frac{1}{\sigma^0} \exp\left\{-\frac{I}{\sigma^0}\right\}$$

↓
averaging of N_L
independent samples
(looks)

$$pdf_I(I|\sigma^0, N_L) = \frac{I^{N_L-1} N_L^{N_L}}{\Gamma(N_L) \sigma^{0N_L}} \exp\left\{-\frac{I N_L}{\sigma^0}\right\}$$

Gamma function ($\Gamma(x+1) = x \cdot \Gamma(x)$)

$$pdf_I(I|\sigma^0, N_L)$$

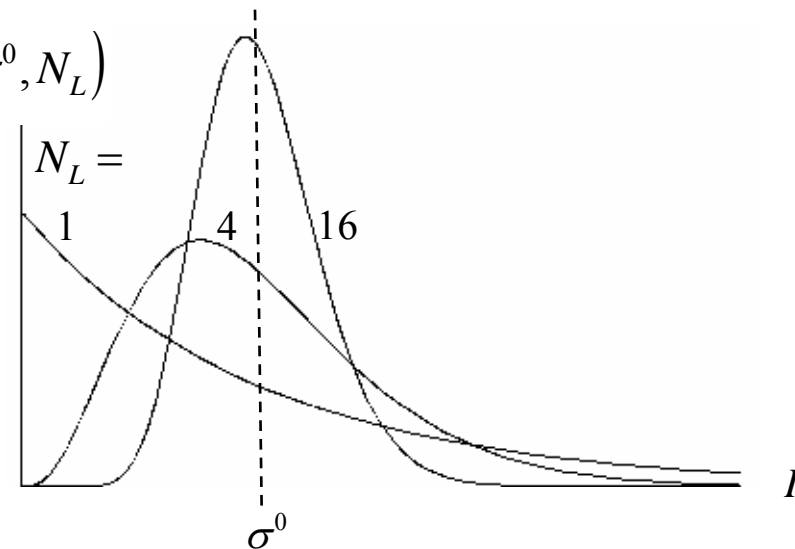

$N_L = 1 \Rightarrow$ standard deviation = mean !



original SAR image
SAR data © AeroSensing GmbH



speckle filtered
Bayesian algorithm

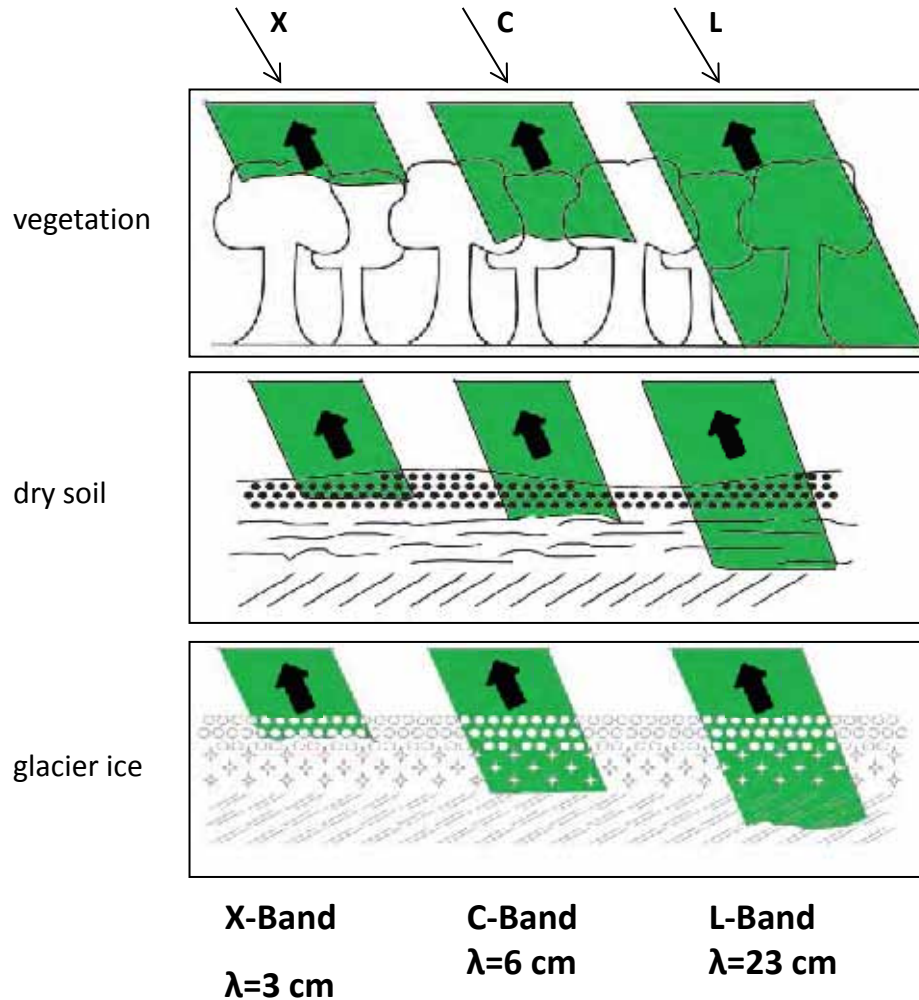

- Metal sphere:

e.g. $R=1\text{ m} \rightarrow \sigma=3.1\text{ m}^2$

$$\sigma = R^2 \pi \quad [m^2]$$

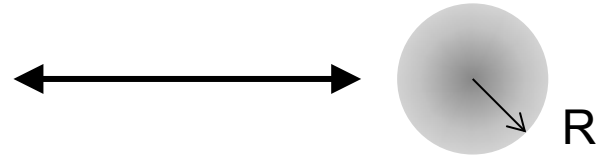

- Corner reflector:

e.g. $L=1\text{ m}, \lambda=5.6\text{ cm} \rightarrow \sigma=74\text{ m}^2$

$$\sigma = \frac{4\pi L^4}{3\lambda^2} \quad [m^2]$$

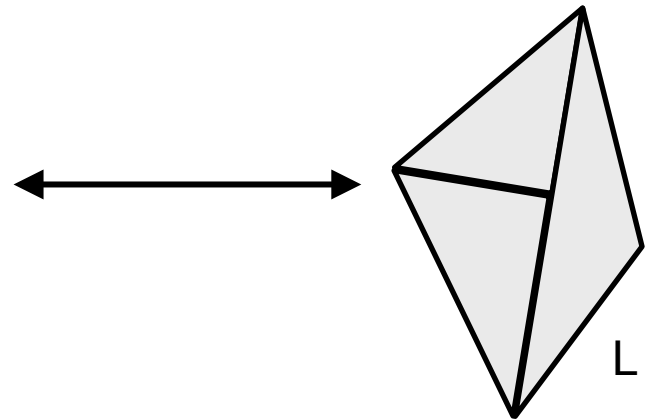

- (1) Sensor transmits horizontally (H) polarized pulse
- (2) H-Pulse is scattered and polarization angle may change
- (3) Sensor receives horizontal and vertical echo components in 2 channels → scattering vector

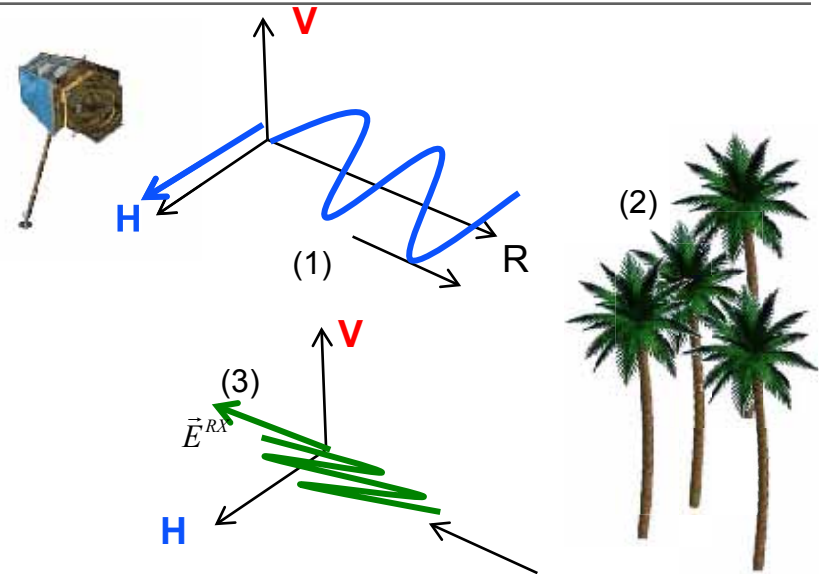

- (4) Sensor transmits vertically (V) polarized pulse
- (5) V-Pulse is scattered and polarization may change
- (6) Sensor receives horizontal and vertical echo components in 2 channels → scattering vector

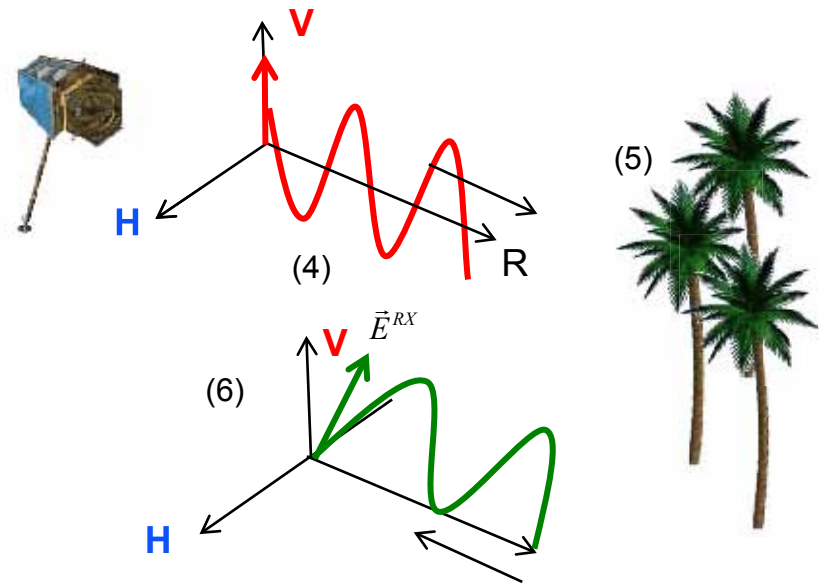

- **Result: 2 x 2 scattering matrix [S]**

$$\begin{bmatrix} E_H^{RX} \\ E_V^{RX} \end{bmatrix} = \begin{bmatrix} S_{HH} & S_{HV} \\ S_{VH} & S_{VV} \end{bmatrix} \begin{bmatrix} E_H^{TX} \\ E_V^{TX} \end{bmatrix}$$

- **Describes polarimetric signature of scattering object**

- **Examples:**

- **Single reflection on metallic plate (or odd number of reflections)**

$$S = \begin{bmatrix} 1 & 0 \\ 0 & 1 \end{bmatrix}$$

- **Random scattering of vegetation**

$$S = \begin{bmatrix} a & b \\ b & d \end{bmatrix}$$

RGB-Composite of Polarisation to Identify Different Scatterers

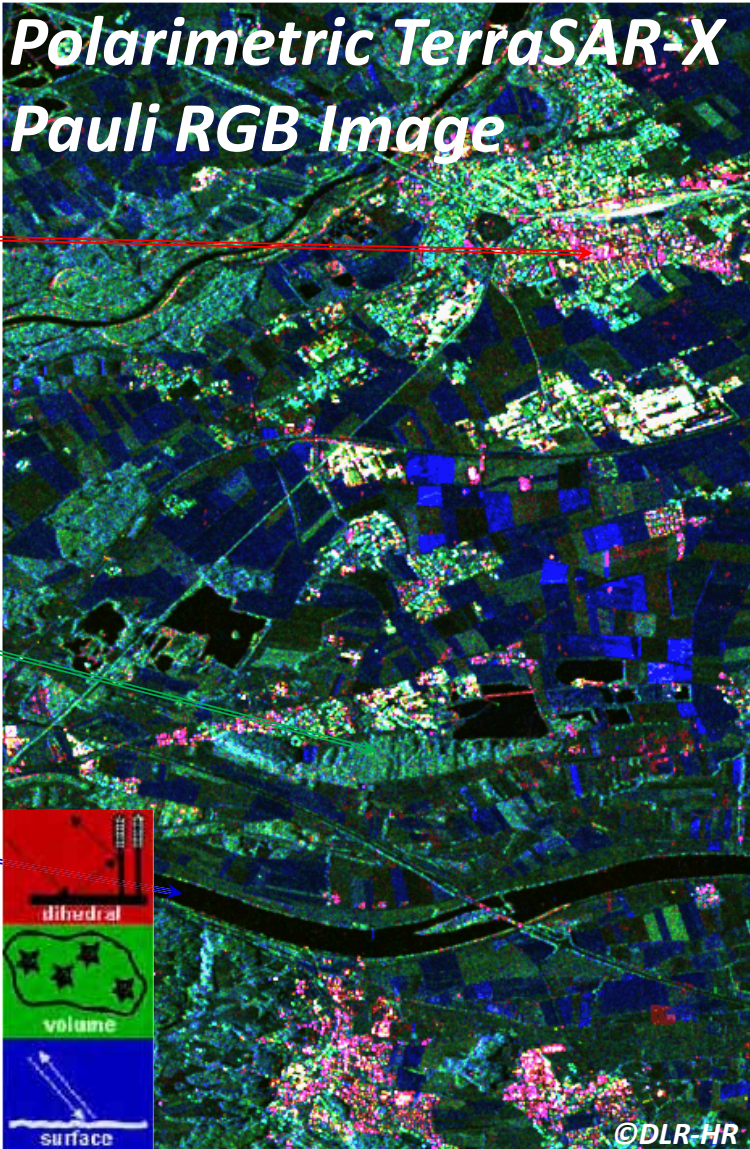
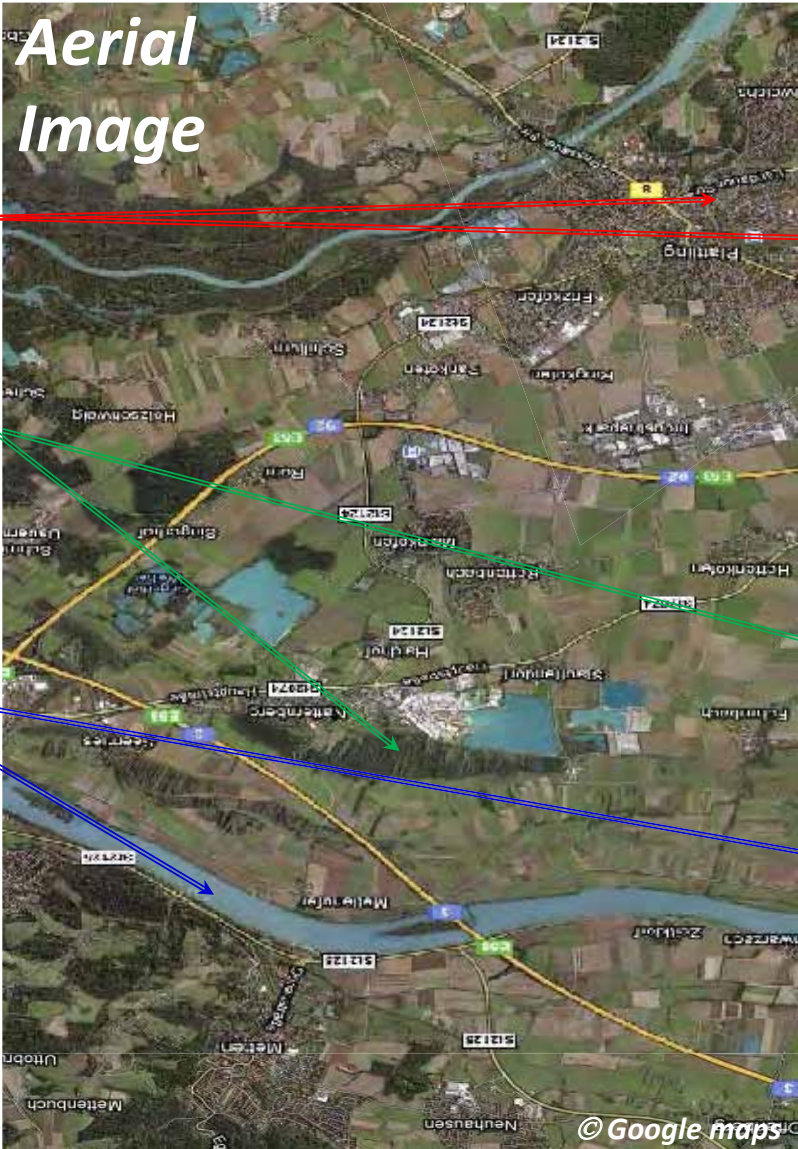

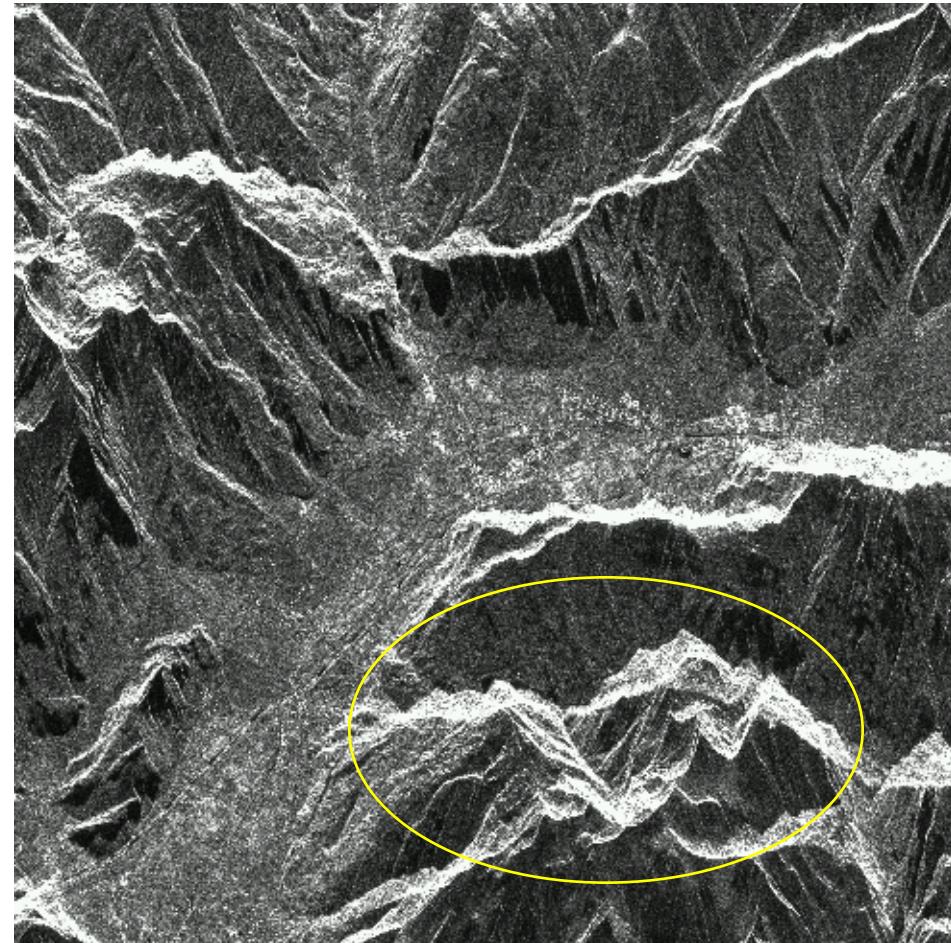
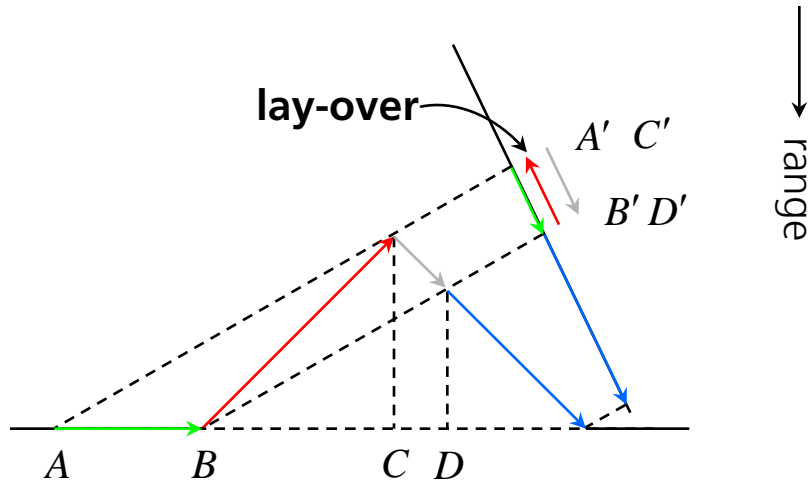

ERS-1
 $\theta = 23 \text{ deg}$

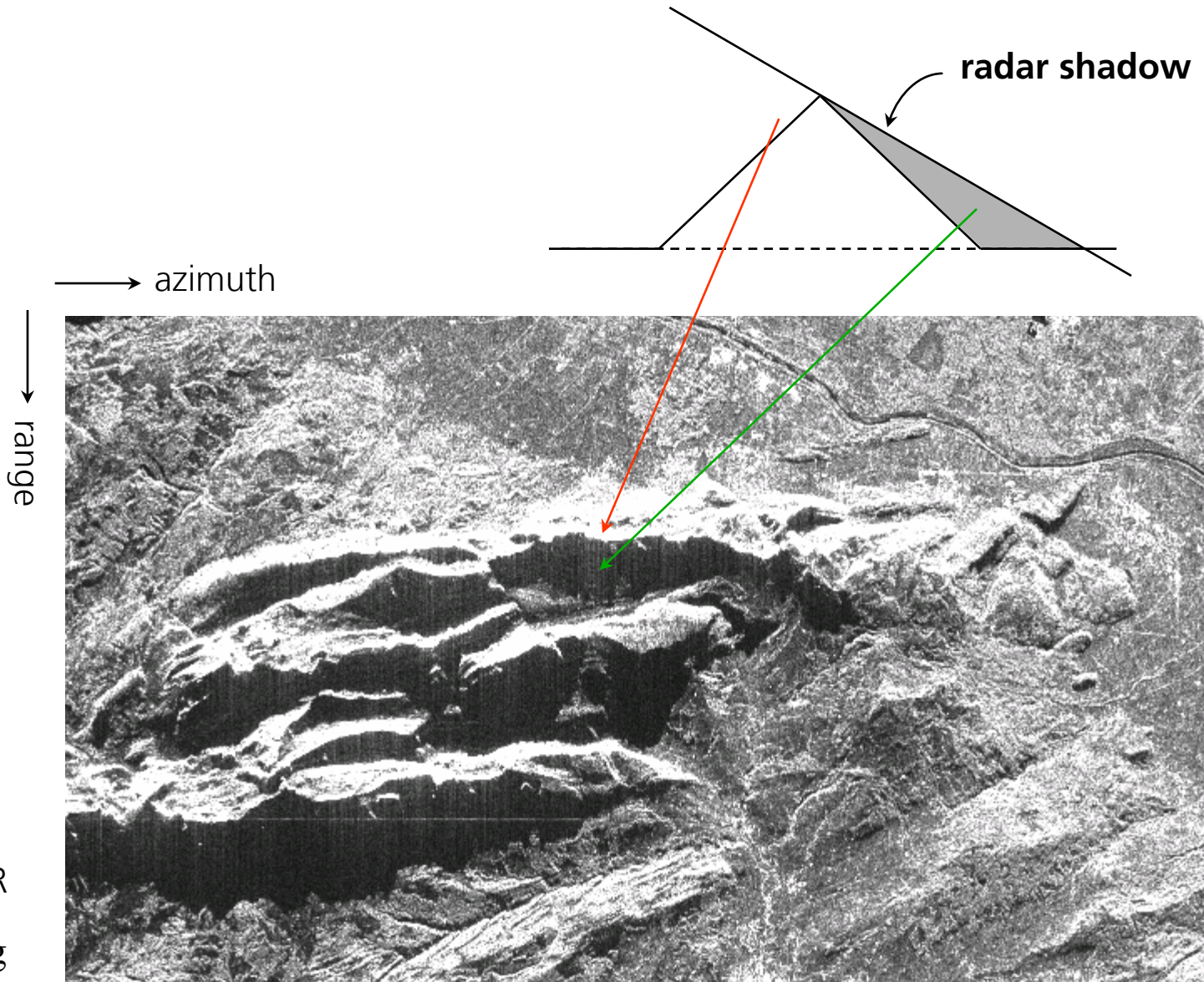

- active ⇒ independent of sun illumination
- microwave ⇒ penetrates clouds and (partially) canopy, soil, snow

wavelengths:	X-band:	3 cm
	C-band:	6 cm
	L-band:	24 cm
- SAR is a two-step imaging process:
 - ▶ **SAR data acquisition:** Illumination of a scattering **object** and collection of received echoes → **raw data**
 - ▶ **SAR processing:** correlation requires difficult precise algorithms → often performed on ground
- **Image properties**
 - ▶ coherent ⇒ interferometry, speckle
 - ▶ polarization can be exploited
 - ▶ spatial resolution:
 - ▶ space-borne: 5 m - 100 m (TerraSAR-X: 0.25 x 0.5 m)
 - ▶ air-borne: > 0.2 m

Satellite	Owner	Band	Resolution	Look Angle	Swath	Lifetime
ERS-1	ESA	C	25 m	23°	100 km	1991-2000
ERS-2	ESA	C	25 m	23°	100 km	1995-2012
Radarsat-1	Canada	C	10 m - 100 m	20° - 59°	50 - 500 km	1995-2013
ENVISAT	ESA	C	25 m - 1 km	15° - 40°	100 - 400 km	2002-2012
ALOS	Japan	L	10 m - 100 m	35° - 41°	70 - 360 km	2006-2011
Cosmo	Italy	X	ca. 1 m - 16 m	2007-
TerraSAR-X & TanDEM-X	Germany	X	1 m - 16 m	15° - 60°	10 - 100 km	2007/2010-
Radarsat-2	Canada	C	3 m - 100 m	15° - 59°	10 - 500 km	2007-
ALOS-2	Japan	L	3 m - 100 m	8° - 70°	25 - 350 km	2014-
Sentinel-1	ESA	C	5 m - 50 m	20° - 46°	20 - 400 km	2014-

Athena Summer School – SAR

Cyprus University of Technology, Lemesos May 2016

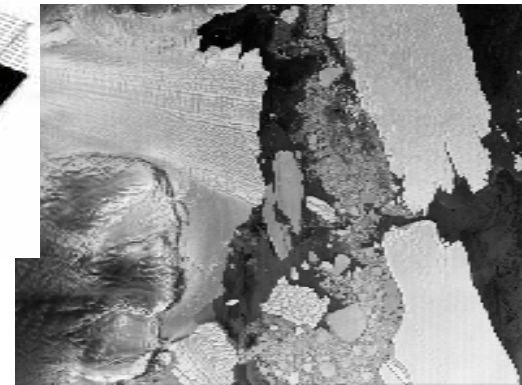
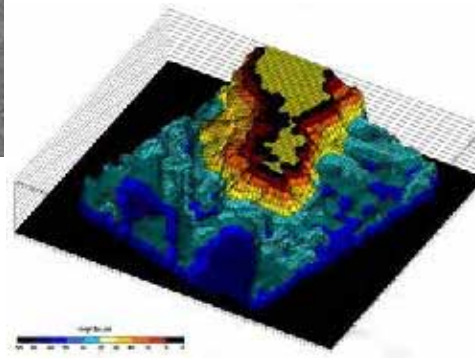

Part 2: Synthetic Aperture Radar (SAR) Applications

Prof. Dr. Michael Eineder (DLR/TUM)

- Oceanography
 - ▶ Wind
 - ▶ Waves
 - ▶ Ships detection
 - ▶ Sea ice & iceberg mapping
- Glaciology
- Geodesy
- Urban Footprint
- Agriculture
- Traffic Monitoring

Maritime Applications / SAR Oceanography

- Founded in 2013 to serve national & international demands for commerce, security & safety
- Point of contact: Dr. Jacobsen



SAR Image of the Ocean

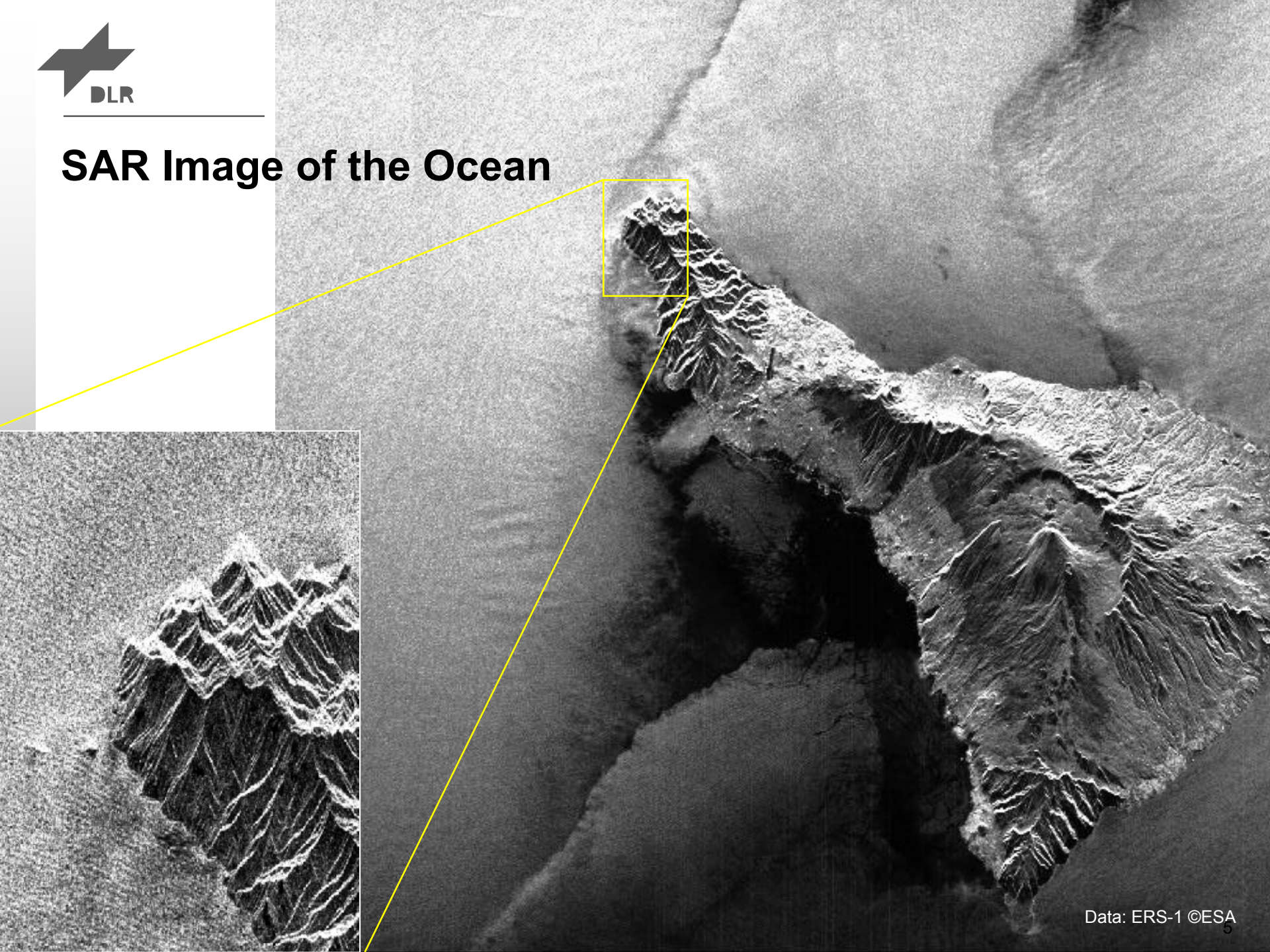

Tropical Cyclones, Hurricanes , Typhoons

Marcel, 2003, ASAR

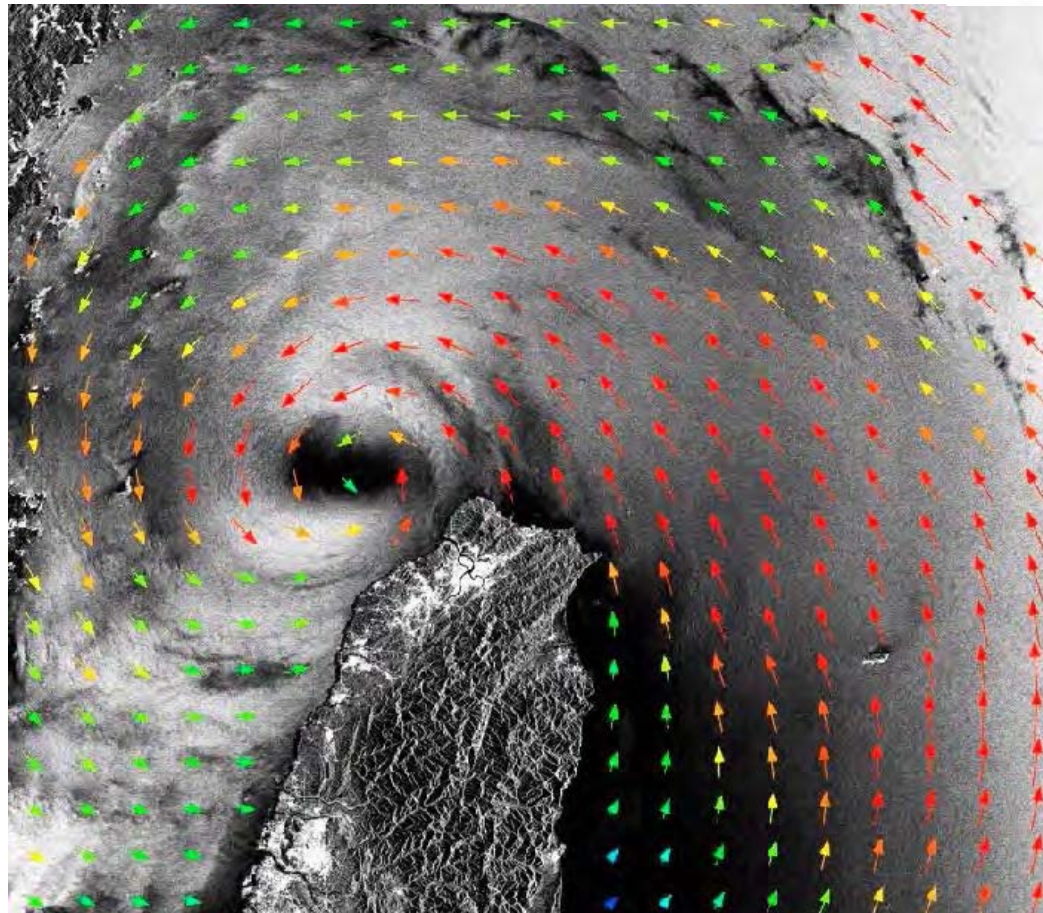
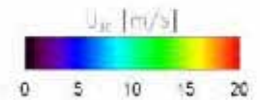

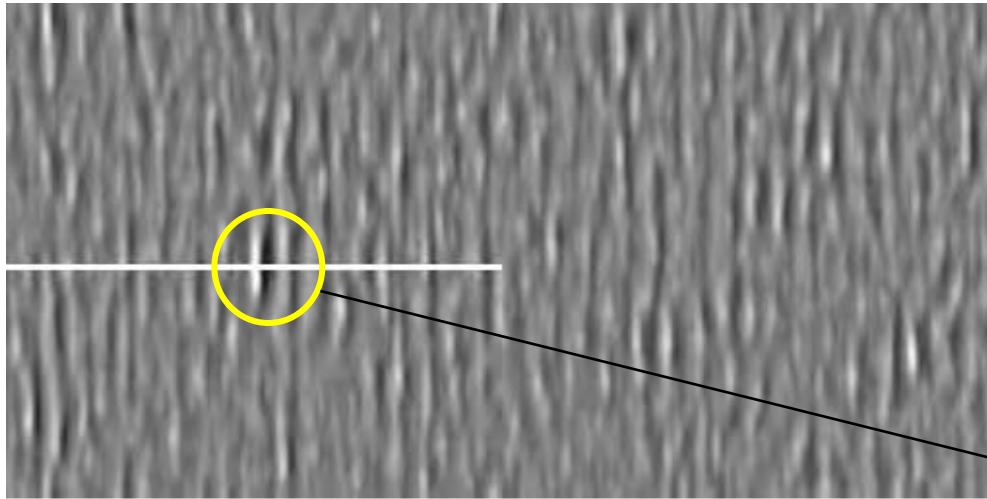

Wave map, derived from SAR image by inversion of mapping equations

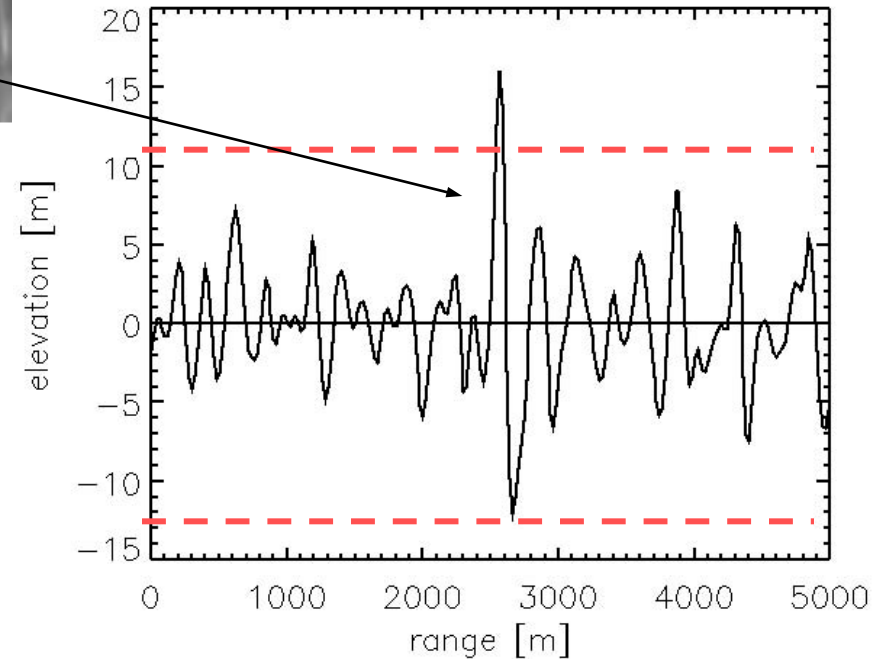
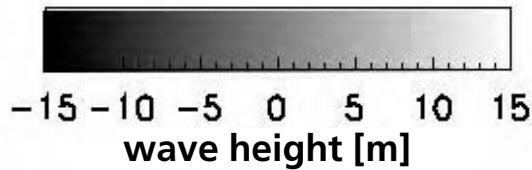

Imagettes with $H_s \geq 7$ m and $U_{10} \geq 15$ m/s in 3x3 Degree Boxes

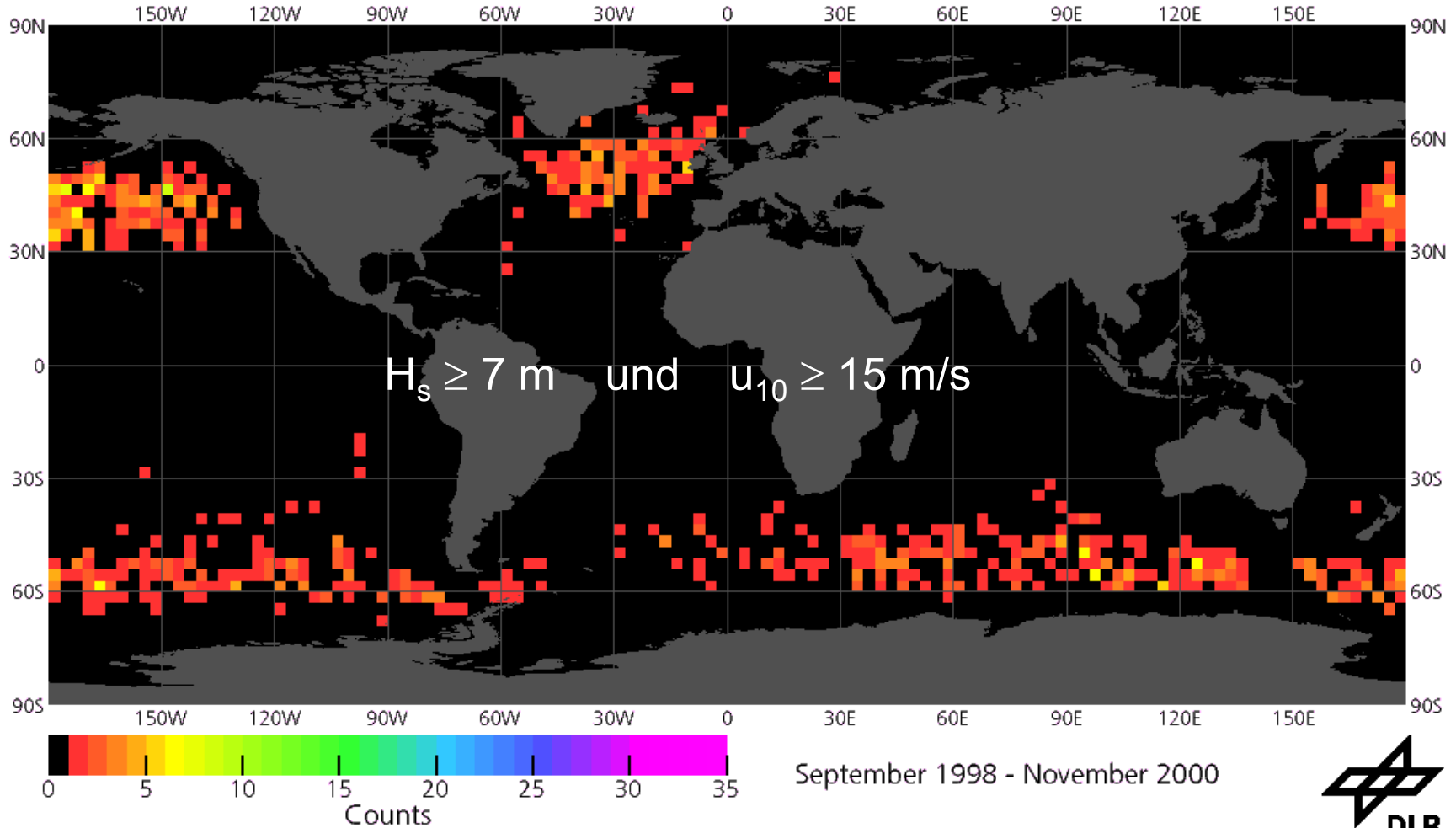

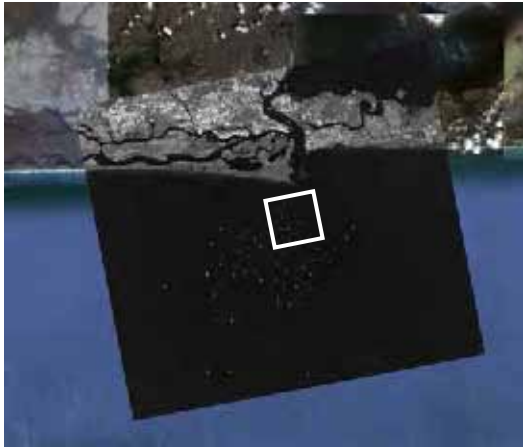

TerraSAR-X Stripmap

Date: 2010-07-15 Location: Lagos

TerraSAR-X

FFI Satellite AIS

ORBCOMM Satellite AIS
at TSX overpass (OHB)

ORBCOMM Satellite AIS
whole day (OHB)

Terrestrial AIS (IHS Live)

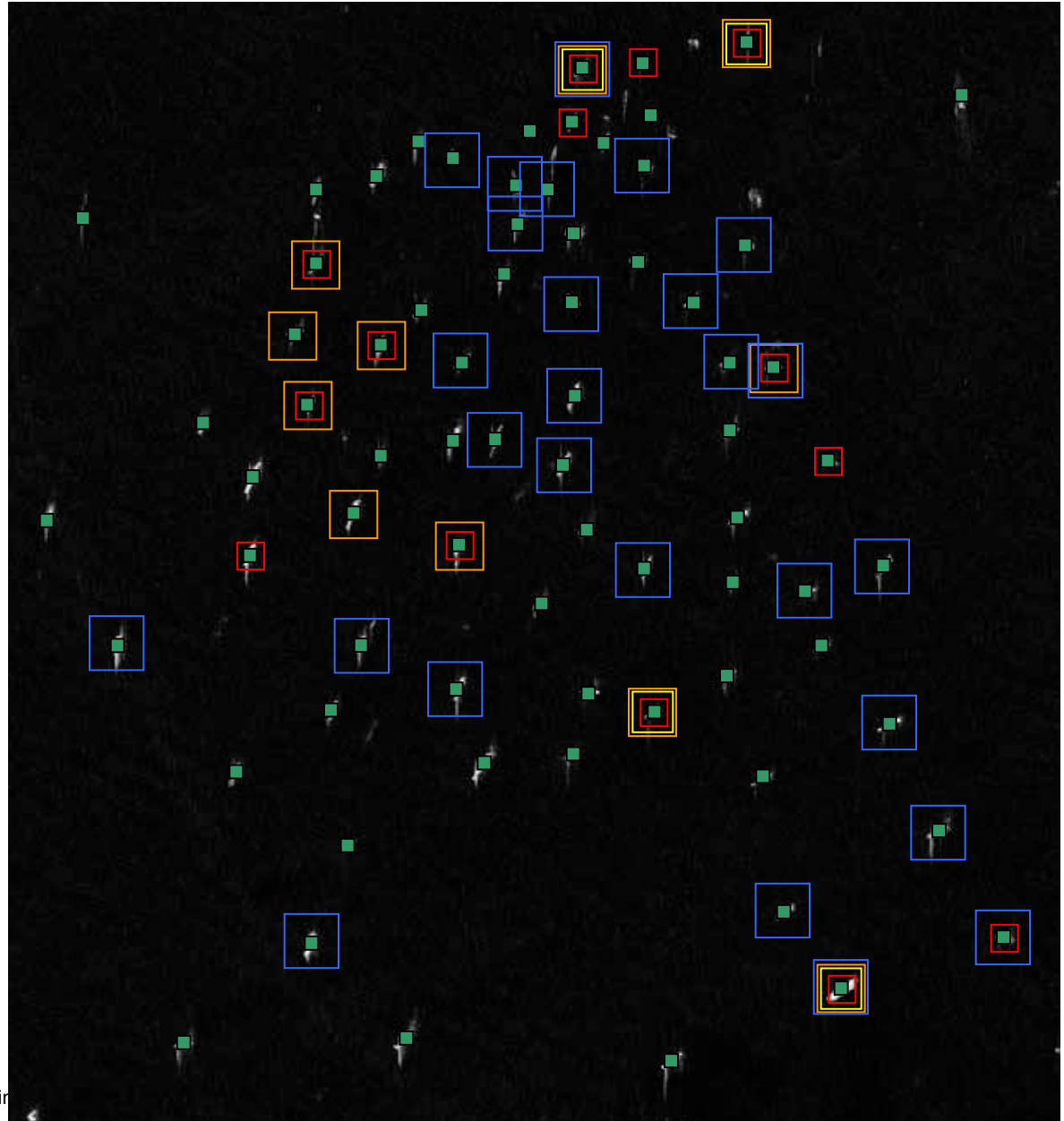



TerraSAR-X, 9. Juli 2010

Deepwater Horizon



Generation of warnings and recommendations for ship routing

Ausschnitt aus der TerraSAR-X ScanSAR Aufnahme • 26.06.2014

Eisberg drift

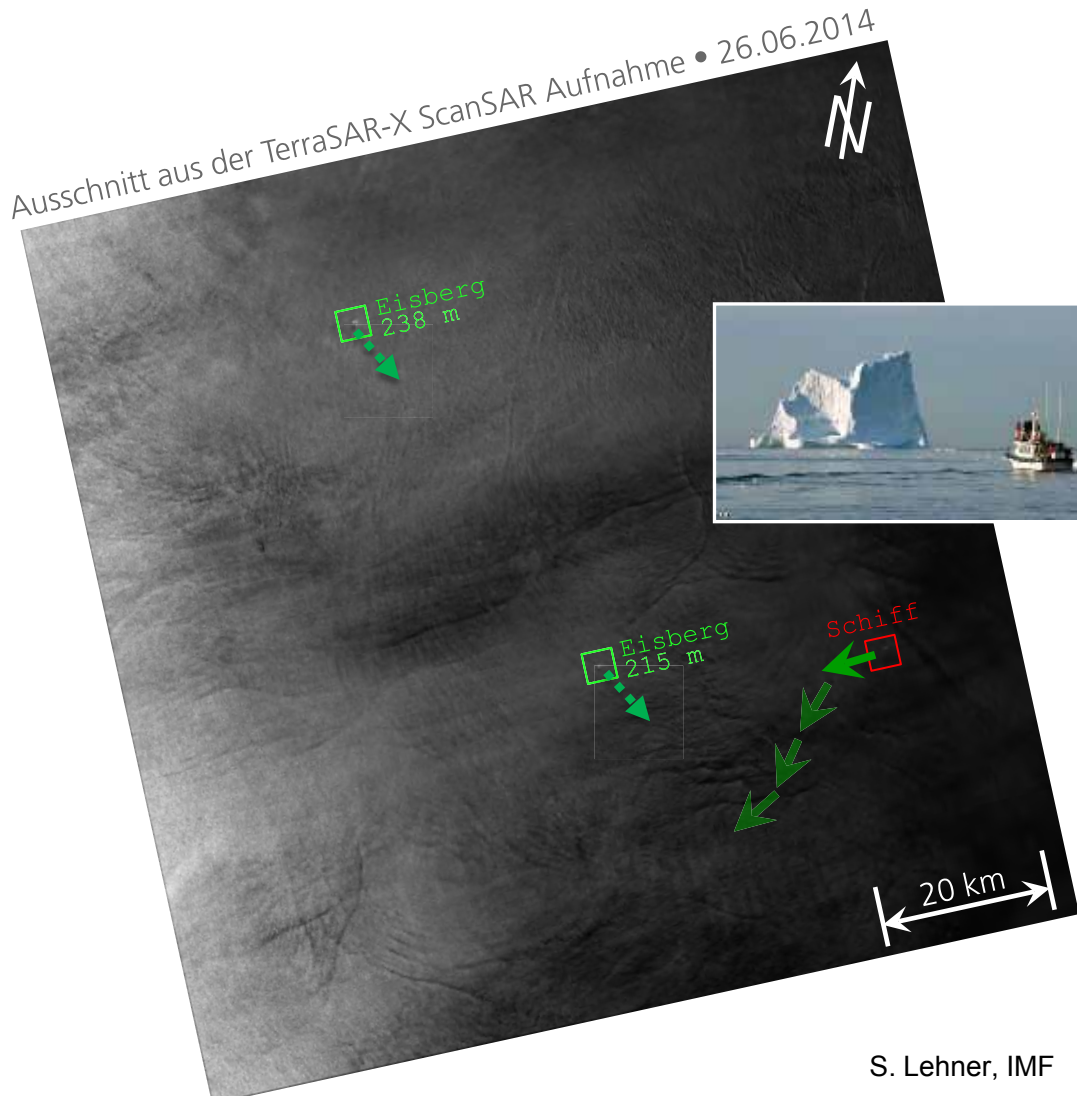

S. Lehner, IMF

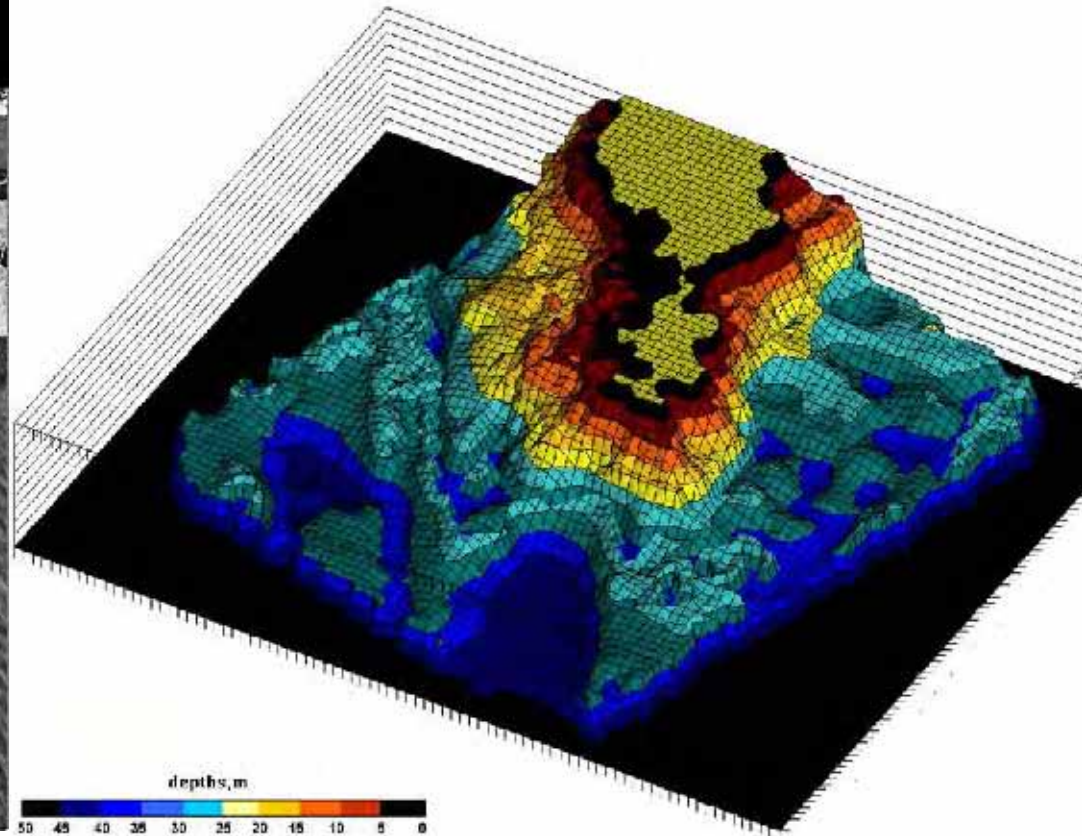
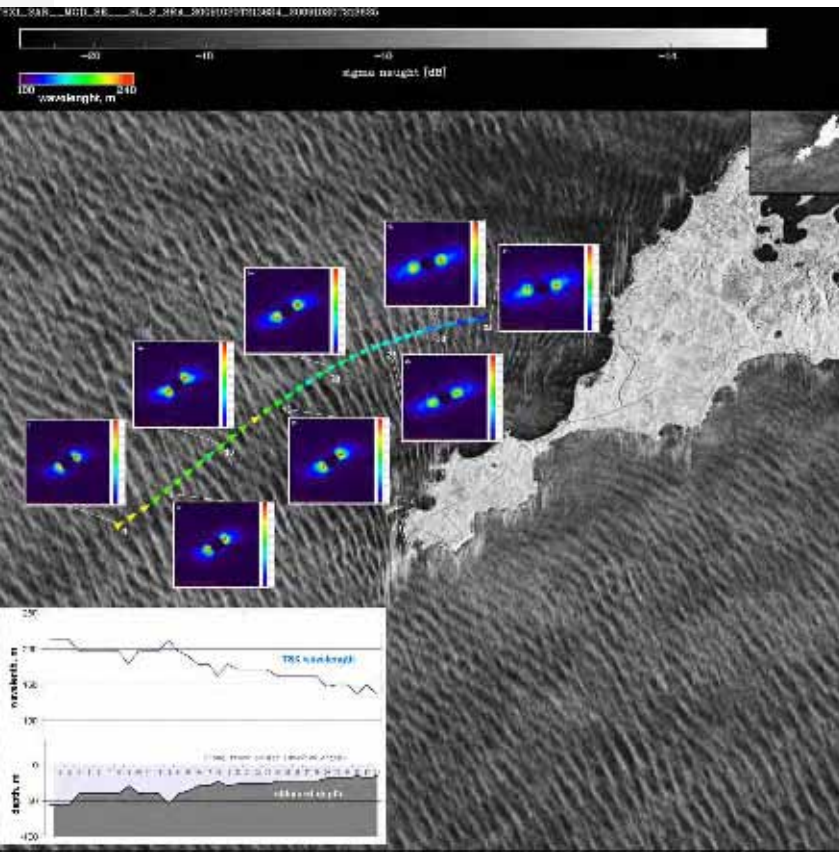

Pleskachevsky, et al., Synergy and Fusion of Optical and Synthetic Aperture Radar Satellite Data for Underwater Topography Estimation in Coastal Areas, Ocean Dynamics, 2011

Emergency Situations

Tōhoku earthquake:
2011-03-11

SAR Images:

TerraSAR-X
2010-10-20,
2011-03-12

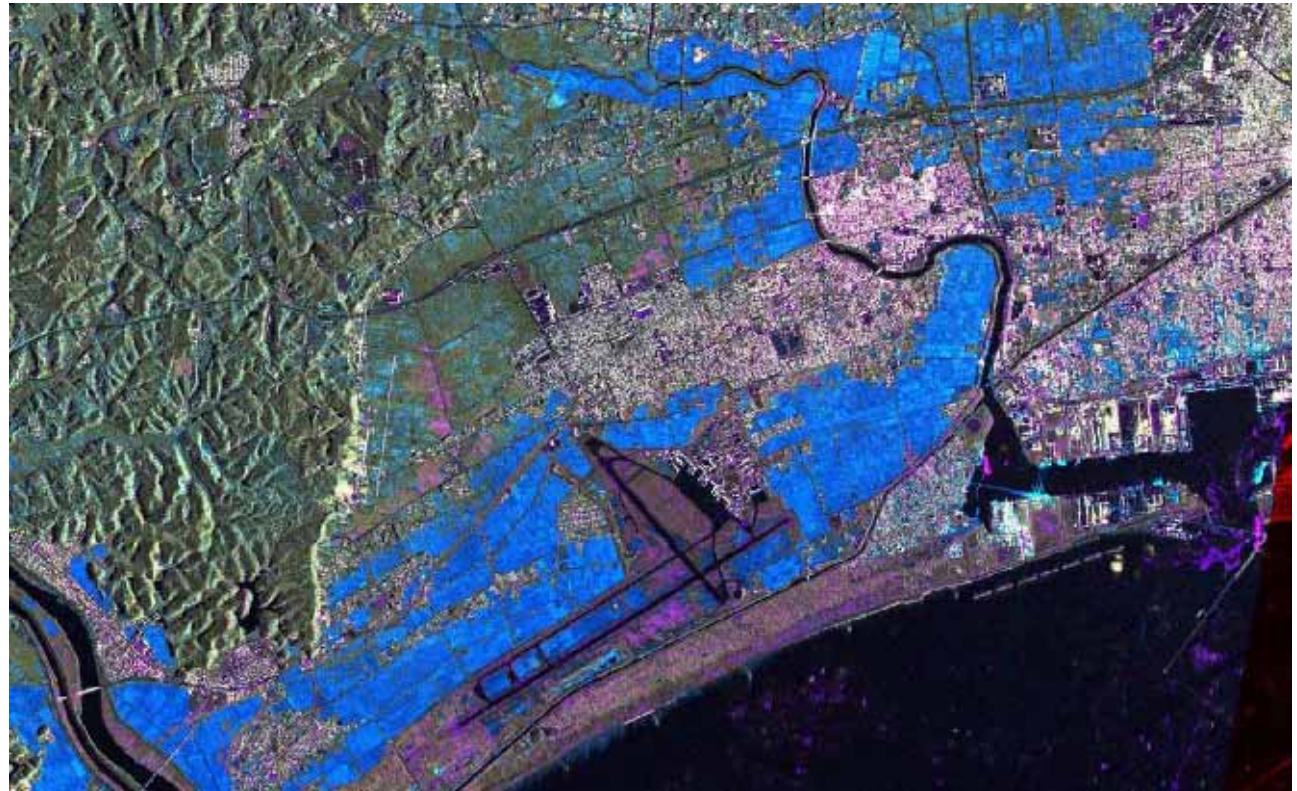

This TerraSAR-X image shows the effect of the tsunami on Higashi-Matsushima Airport and the port of Ishinomaki in the Sendai region on the east coast of Japan. The blue areas indicate flooding; the magenta-coloured areas reveal the extent of the destruction.

Early Response:

Eruption of
Soufrière Hills Volcano,
Montserrat Island,
Caribics, 2008-07-28

Red: 2007-10-09

Green: 2008-08-01

Blue: Difference

G. Wadge, University of Reading
T. Fritz, DLR

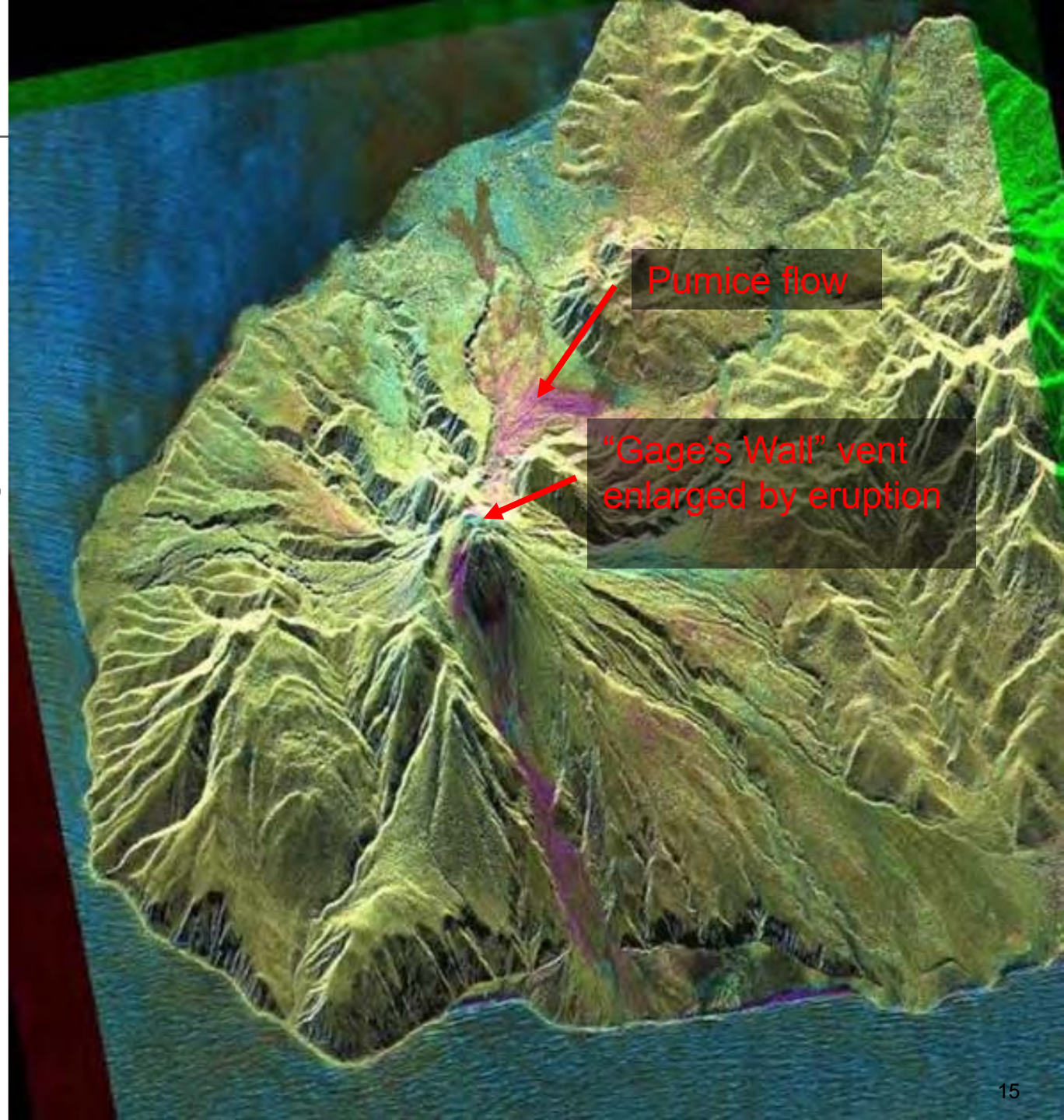

Glaciology

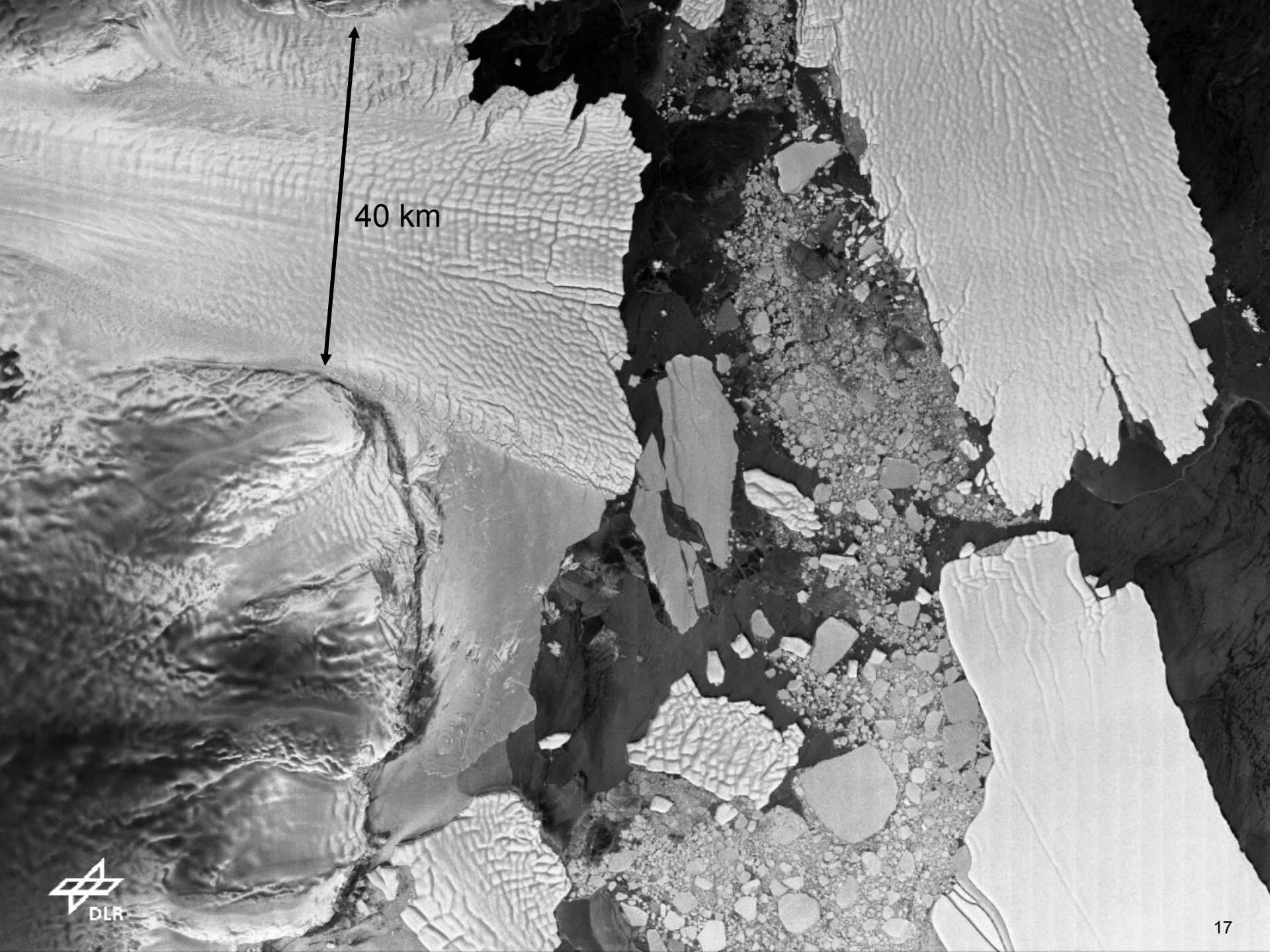

40 km



Ice export velocity doubled since 1995

M. Eineder, DLR

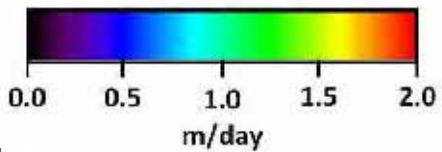
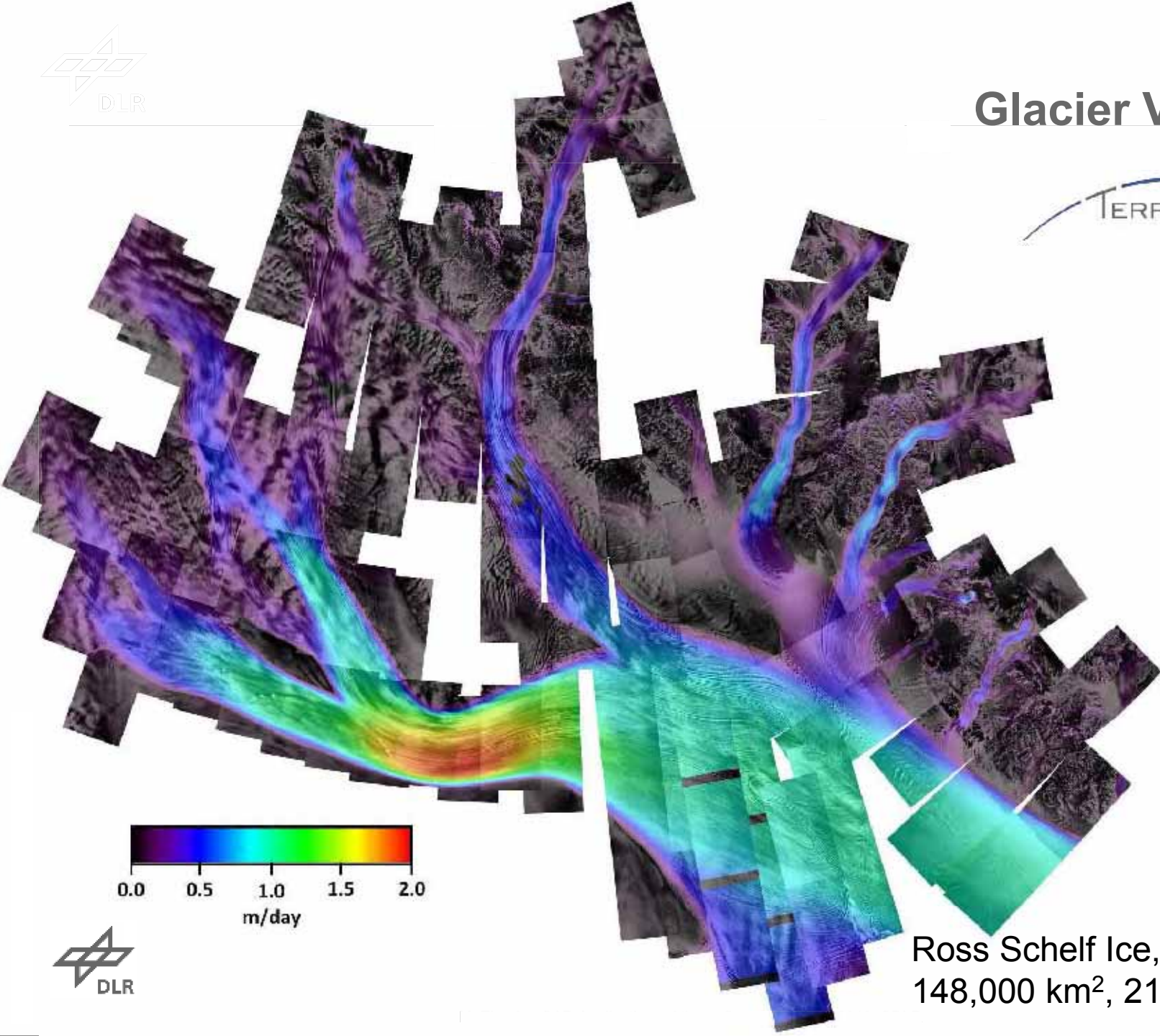

Geodesy

Point Positioning Accuracy: SAR versus GNSS

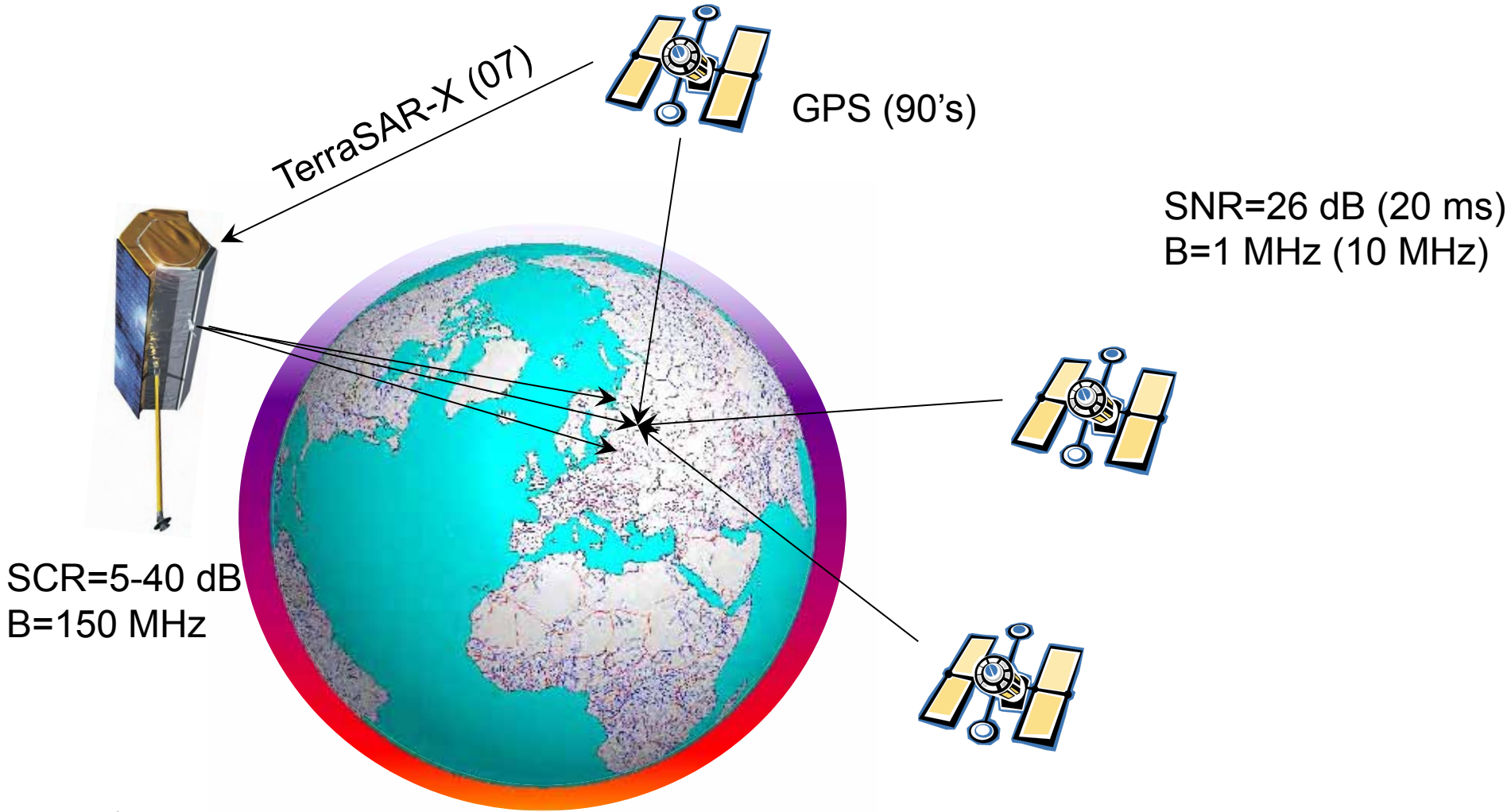

Yes, it is Possible to Localize Objects with cm Accuracy

Local TSX positioning accuracy of a CR, corrected for solid earth tides, atmospheric refraction (H₂O, TEC), pole tides etc.

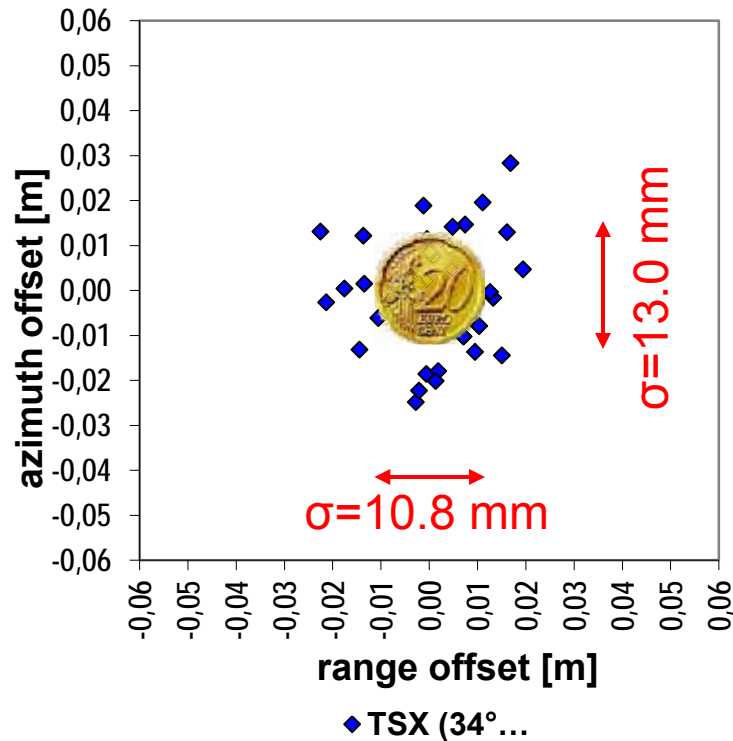

Literature:

- 1) Eineder, M., Minet, C., Steigenberger, P., Cong, X., Fritz, T., Imaging Geodesy—Toward Centimeter-Level Ranging Accuracy With TerraSAR-X. IEEE TGRS, 2011
- 2) Schubert, A., Jehle, M., Small, D., Meier, E., Mitigation of atmospheric perturbations and solid-Earth movements in a TerraSAR-X time-series, J. of Geodesy, 86(4), 2012.
- 3) Cong, X., Balss, U., Eineder, M., Fritz, T., Imaging Geodesy—Centimeter-Level Ranging Accuracy With TerraSAR-X: An Update. IEEE GRSL, 2012
- 4) Gisinger, C., Balss, U., Pail, R., Zhu, X.X., Montazeri, S., Gernhardt, S., Eineder, M., Precise Three-Dimensional Stereo Localization of Corner Reflectors and Persistent Scatterers With TerraSAR-X. IEEE TGRS, 2015
- 5) Schubert, A., Small, D., Miranda, N., Geudtner, D., Meier, E., Sentinel-1A Product Geolocation Accuracy: Commissioning Phase Results, Remote Sens, 2015



Application: 3D Coordinates from TerraSAR-X Stereo

→ DLR/HGF-Project DriveMark®



Lantern



Application: 3D Coordinates from TerraSAR-X Stereo

→ DLR/HGF-Project DriveMark®

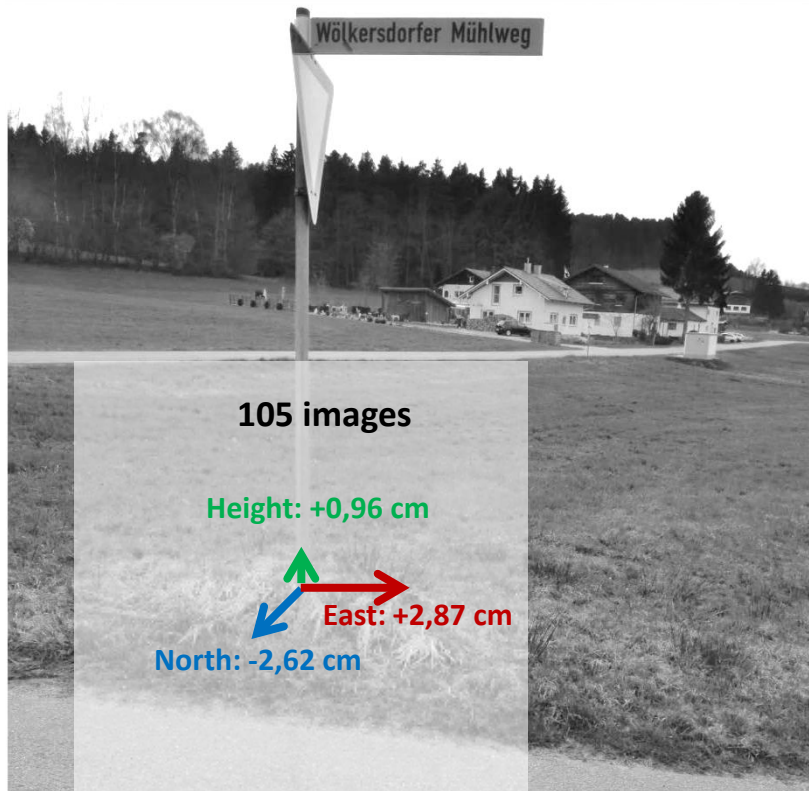

Lantern

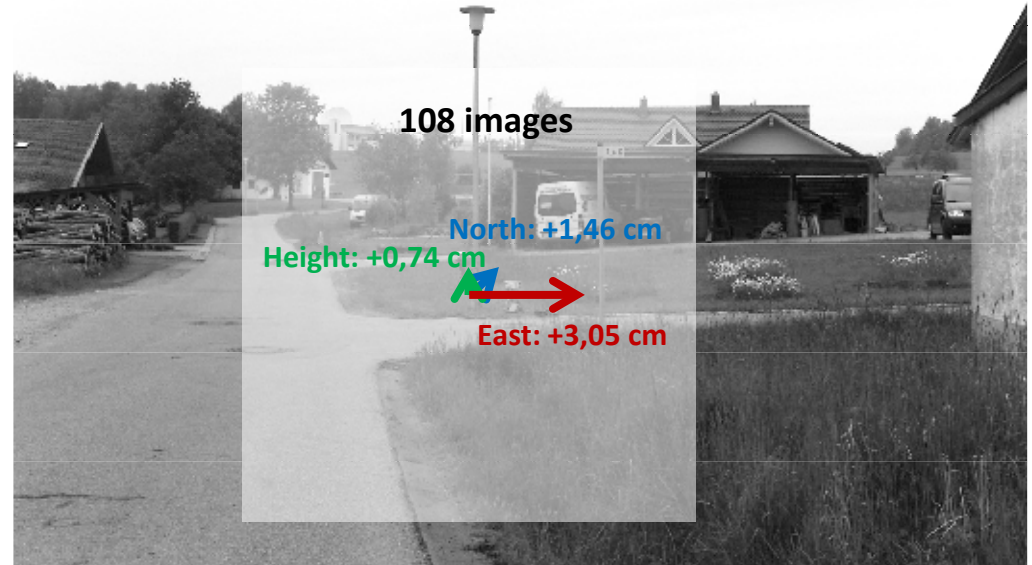

Urbanization

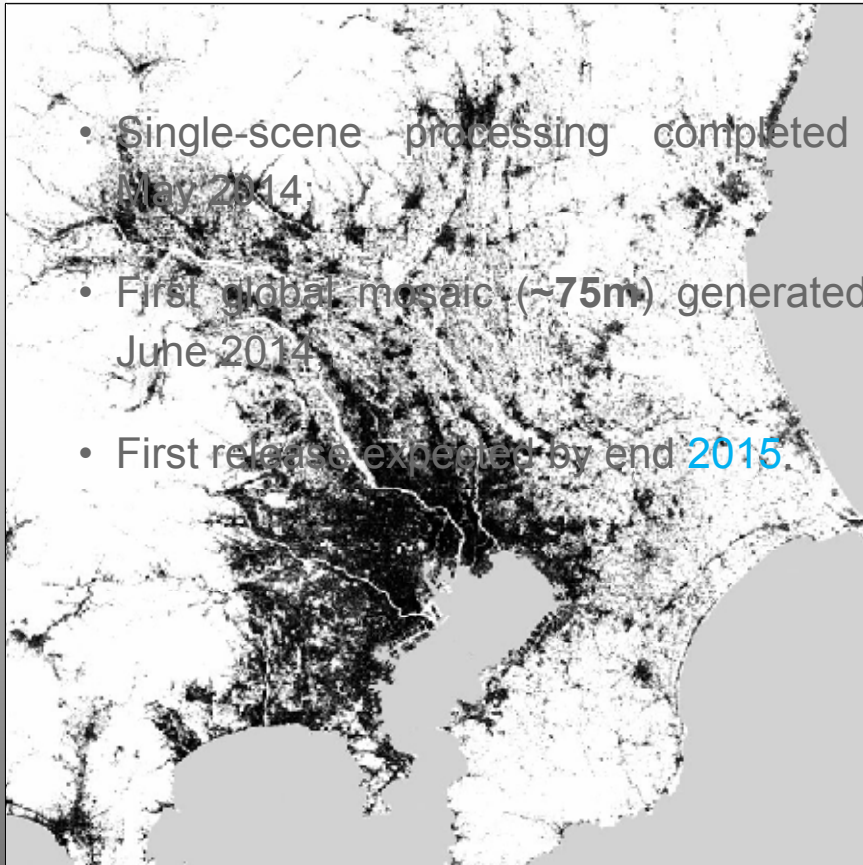

- Single-scene processing completed in May 2014
- First global mosaic (~75m) generated in June 2014
- First release expected by end 2015



www.dlr.de/guf

Agriculture



RGB-Composite of Polarisation to Identify Different Scatterers

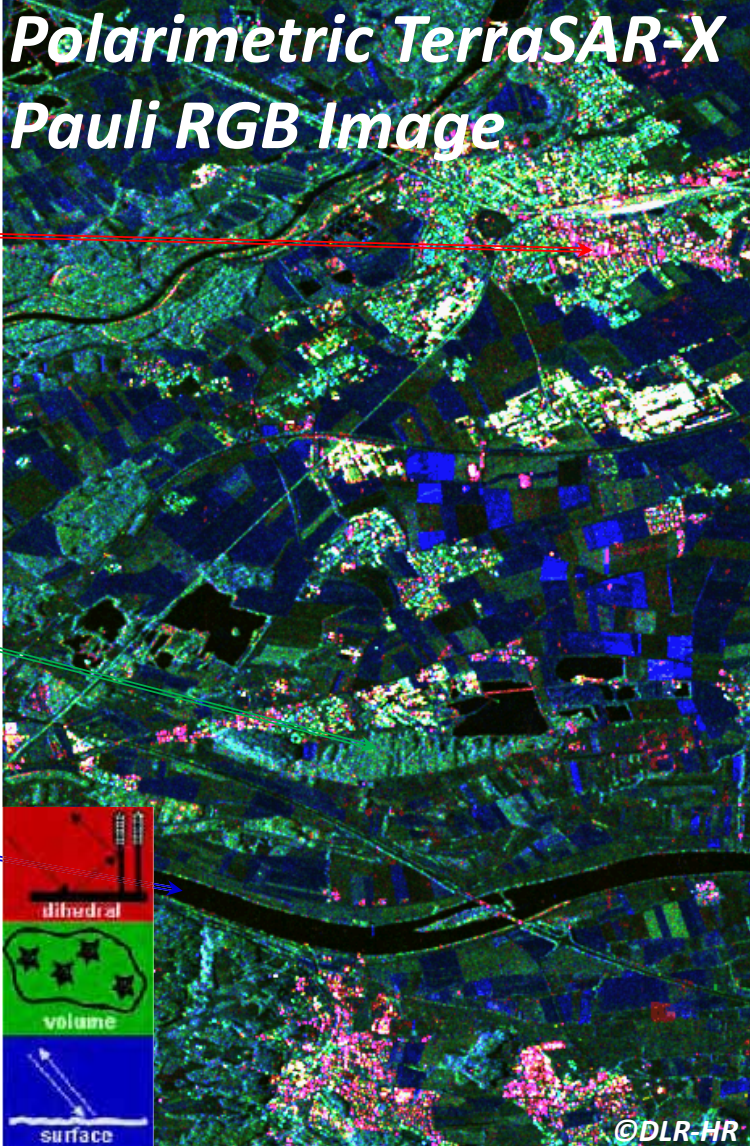
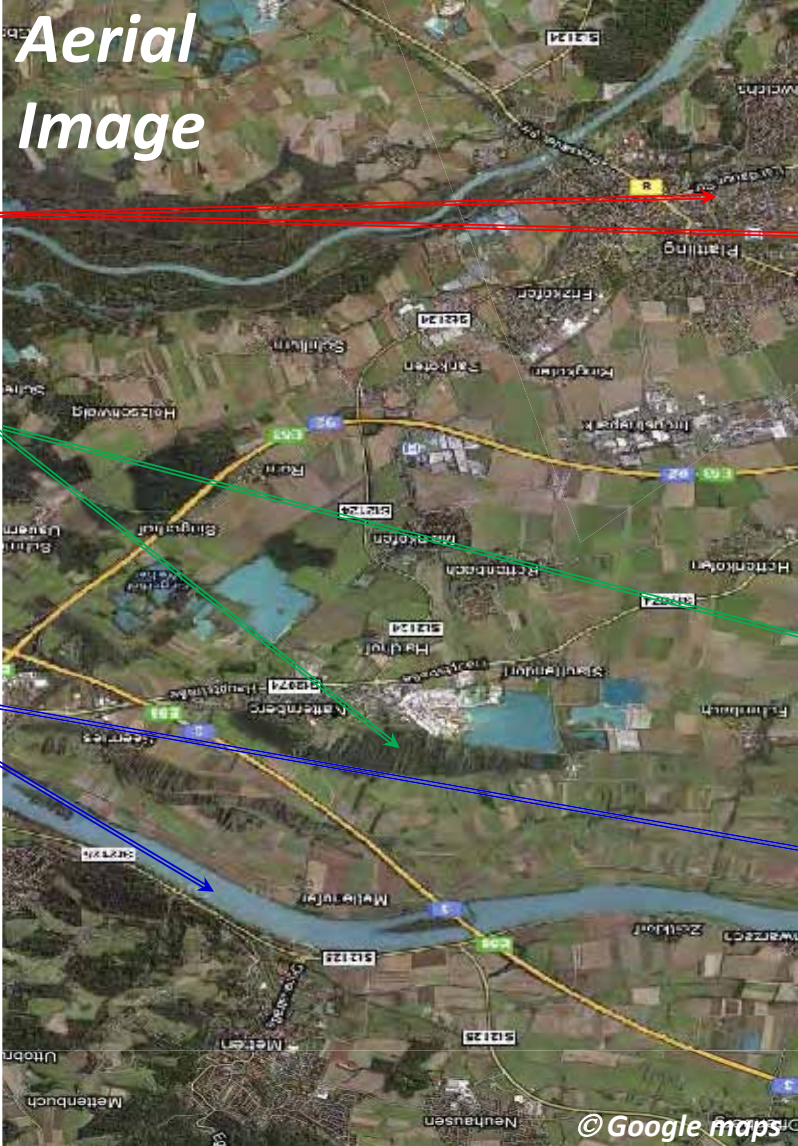

System parameters - polarisation

Airborne E-SAR data acquired on June 14, 2000 near Alling, Bavaria, Germany

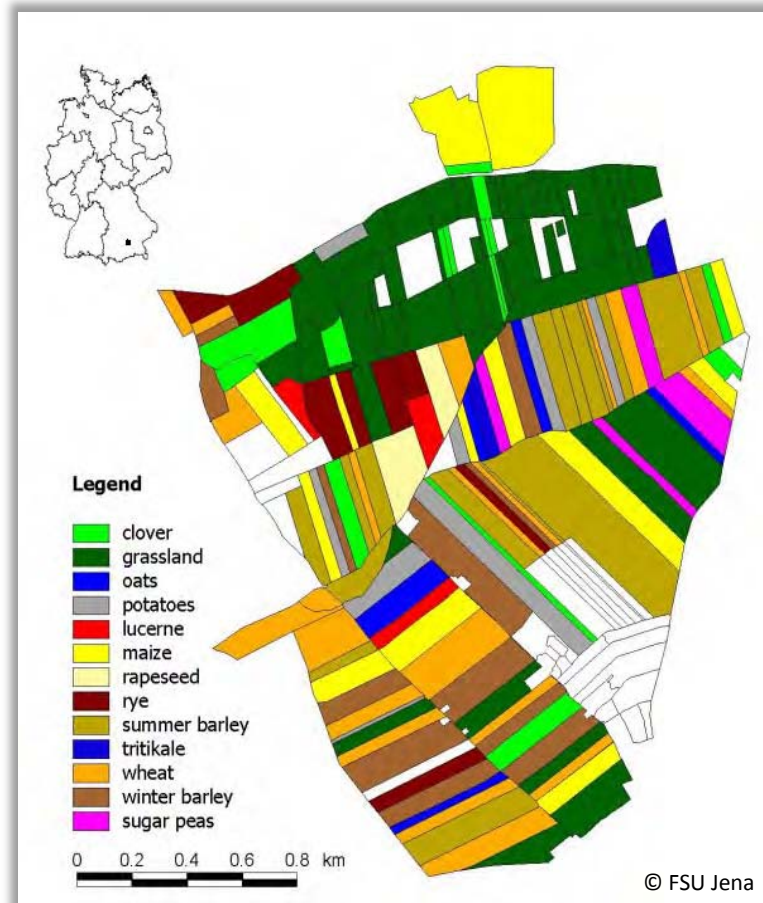
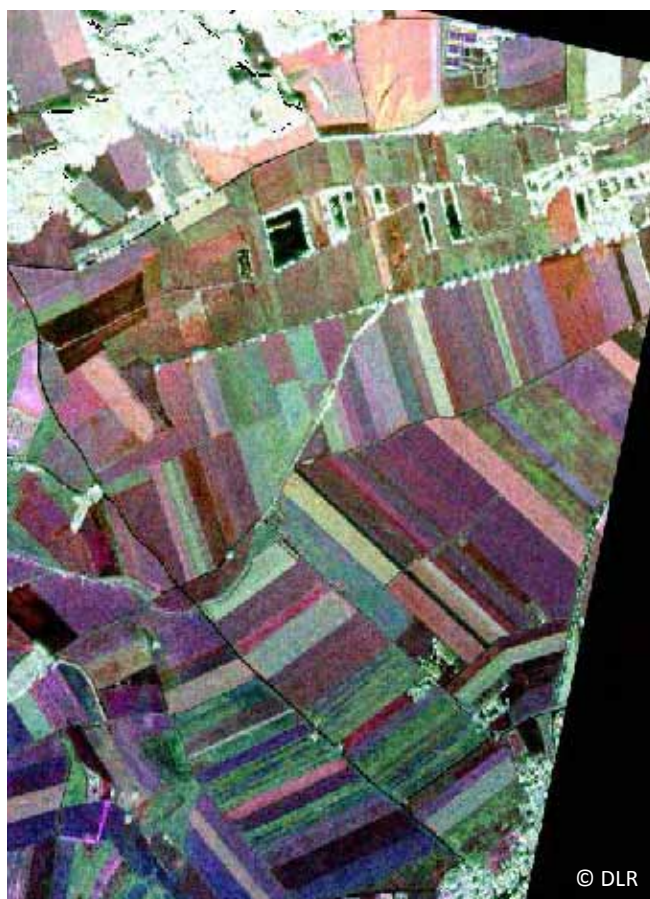
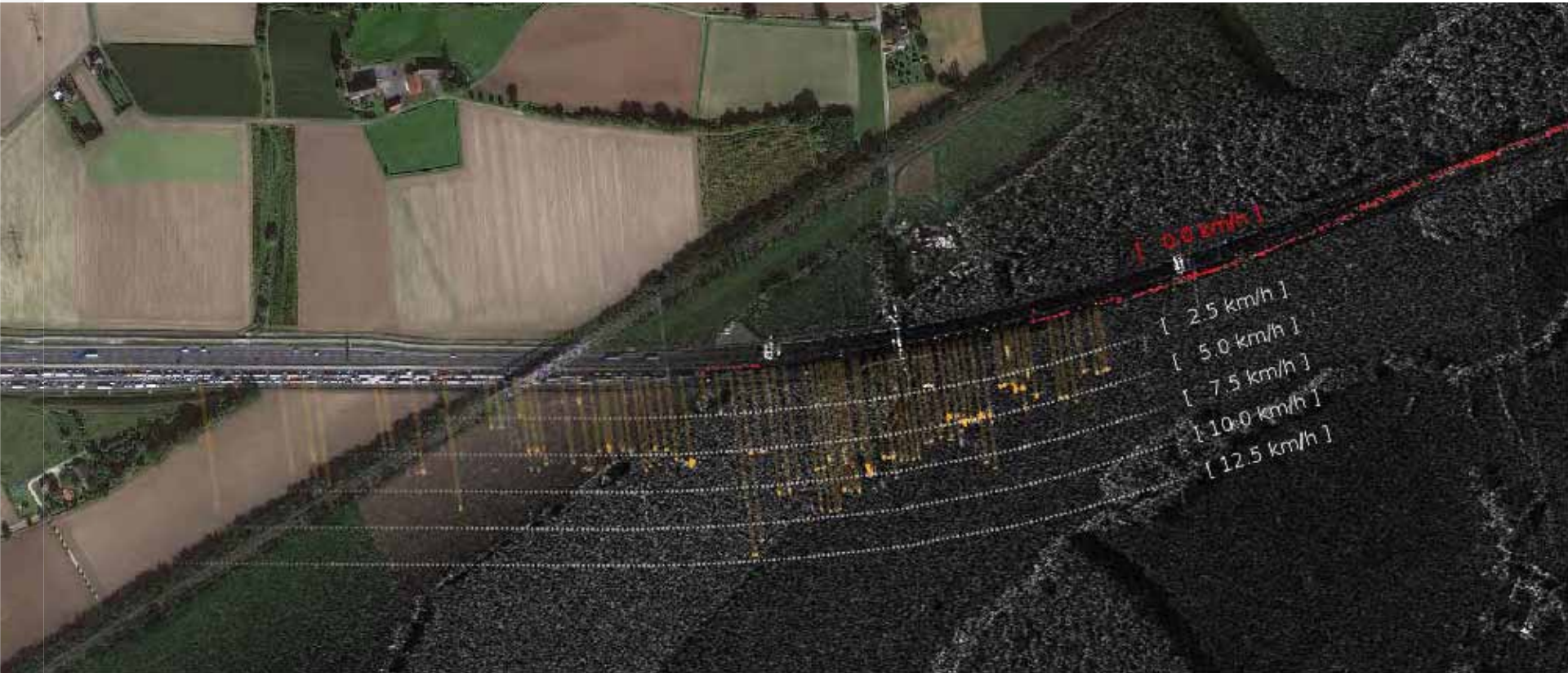

Fig.: L-VV-L-HV-L-HH composite (left) and crop map (right)

Traffic Monitoring



Measurement of traffic density and velocity (from displacement and along track interferometry) with TerraSAR-X

Further SAR-Education Ressources ...

ESPACE – Earth Oriented Space Science and Technology

International Master's Program

www.espace-tum.de

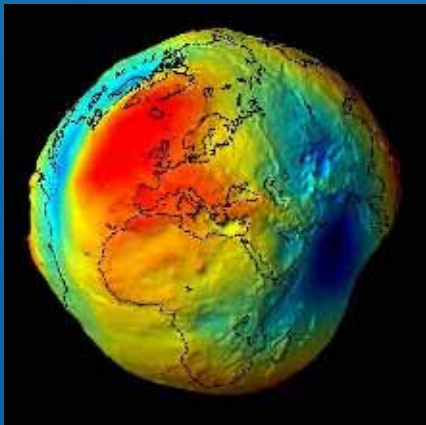

Main topics

Master's program SPACE combines elements of engineering and science in one single interdisciplinary program

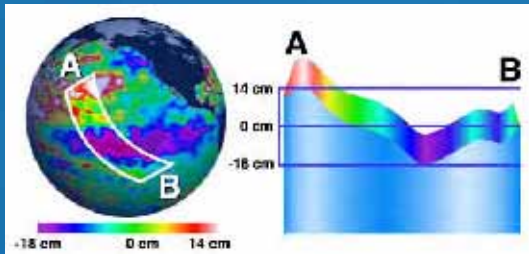

Earth System



Remote Sensing

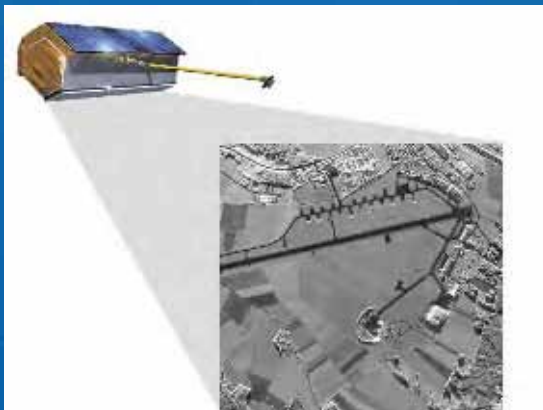

Satellite Technology

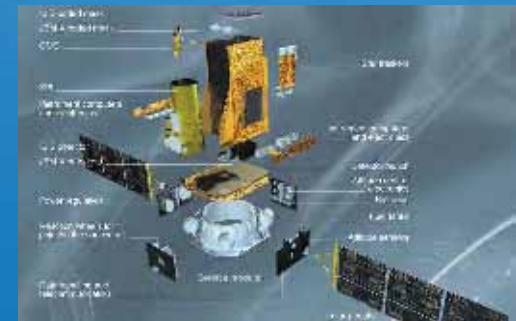

Navigation

Munich

Earth oriented satellite technology in industry, research institutes and at universities

- 3 Universities
- German Geodetic Research Institute
- German Aerospace Center (DLR)
- EADS-Astrium
- ...



Cooperating institutions



Location

CCG-Center, Technologiepark Argelsrieder Feld 11,
D-82234 Wessling-Oberpfaffenhofen

A list of nearby accommodations, a description of the location and hints for travel will be mailed to the participants upon registration. Please make your own hotel accommodation.

Fee

EUR 1.980,-

CCG is a non-profit organisation, exempt from value-added tax in Germany. For foreign seminar locations the local tax regulations are applicable.

Members of CCG receive a discount of 10 %. Where several employees from one company / office apply for the same course, each participant will receive a discount of 10 %. For students special rates are available on request. Discounts cannot be combined.

Please pay by non-cash means after receiving the invoice.

Registration

Please write or call (up to 3 weeks before the seminar) to
Cari-Cranz-Gesellschaft e.V., P.O. Box 11 12, D-82230 Wessling
Tel. +49 (0) 8153 / 88 11 98 -12, Fax -19, E-Mail: anmelden@cog-ev.de
Internet: www.cog-ev.de

After receipt of registration, a confirmation letter will be sent.

Further Information

For more information about our organization please do not hesitate to contact the CCG at Oberpfaffenhofen at the phone number given above.

For more information on the content of the seminar please contact

Prof. Dr. Irena Hajnsek, DLR, German Aerospace Center
Oberpfaffenhofen, D-82234 Wessling
Phone: +49 (0) 8153 / 28-2363, E-Mail: irena.hajnsek@dlr.de

Substitutions and Cancellations

Substitutions may be made at any time. Cancellation of an accepted registration made up to 7 days prior to the start of the seminar is subject to a EUR 25,- administrative fee. Participants canceling after that date are responsible for the entire seminar fee.

CCG reserves the right to cancel a course up to 10 days before the course's beginning in case of low number of participants or for other significant reasons. Furthermore, CCG reserves the right, against the announcement in the programme, to possibly replace at short notice a lecturer and also the lecturer's topic. Any claims for damages shall be excluded.

Focus

The course provides a thorough introduction to Synthetic Aperture Radar (SAR) and its applications, including basic SAR principles and practical design examples of both airborne and spaceborne SAR systems. The signal processing techniques and algorithms required to produce a radar image are fully described and various applications of SAR polarimetry, SAR interferometry, polarimetric SAR interferometry and differential SAR interferometry will be introduced. Tools and methods are presented for SAR data analysis and image interpretation. Further, new satellite concepts and DLR airborne SAR activities are presented.

Who Should Attend

Engineers and scientists from all branches of the aerospace and radar industry and geosciences research community interested in the theory, design and application of active imaging radar.

Material

Each attendant will be provided with detailed course material in English.

Language

English

Lecturers

R. Bamler	Prof. Dr.	Remote Sensing Technology, DLR, Oberpfaffenhofen
M. Eineder	Prof. Dr.	
Y.-L. Desnos		ESA, ESRIN, Frascati (I)
A. Ferretti	Dr.	Tele-Rilevamento Europa T.R.E. s.r.l., Milano (I)
G. De Grandi	Dr.	Aberystwyth University (UK)
Irena Hajnsek	Prof. Dr.	ETH Zürich (CH) DLR, Oberpfaffenhofen
Susanne Lehner	Prof. Dr.	DLR, Bremen
H. Rott	Prof. Dr.	University of Innsbruck (A)
A. Roth		German Remote Sensing Data Center, DLR, Oberpfaffenhofen
S. Baumgartner	Dr.	
R. Hom		Microwaves and Radar Institute, DLR, Oberpfaffenhofen
G. Krieger	Dr.	
A. Moreira	Prof. Dr.-Ing.	
K. Papathanassiou	Dr.	

Seminar SE 2.06**SAR Principles and
Application**

October 26 – 30, 2015
Oberpfaffenhofen near Munich

Scientific Coordination

Prof. Dr. Irena Hajnsek
DLR, German Aerospace Center
Oberpfaffenhofen

Seminar Outline

Monday, October 26, 2015
10.15 – 17.00

- 10.15 – 10.30 Introduction
- 10.30 – 12.00 **SAR Basics**
A. Moreira Basics of imaging radar incl. principle of SAR signal and image formation · Overview of applications and existing air- and spaceborne systems
- 13.00 – 14.30 **SAR Theory**
A. Moreira Basic theory for SAR signal modeling and processing · Point and distributed targets, SAR signal and image properties · Overview of SAR systems and technologies
- 15.00 – 17.00 **Advanced and Future SAR Systems**
A. Moreira Advanced SAR Imaging modes · Overview of future SAR developments and applications

Tuesday, October 27, 2015
08.30 – 16.30

Techniques and Applications

- 08.30 – 10.00 **SAR Interferometry I**
R. Bamler Different principles of SAR interferometry and the concept of coherence, DEM generation
- 10.30 – 12.00 **SAR Interferometry II**
R. Bamler M. Eineder Achievable accuracy, error sources, fundamental limits, e.g. critical baseline, basics of D-InSAR, SAR tomography
- 13.00 – 14.30 **SAR Polarimetry I**
I. Hajnsek Background of SAR polarimetry in terms of fundamentals of wave polarimetry, scattering polarimetry and decomposition theorems · Practical examples
- 15.00 – 16.30 **SAR Polarimetry II**
I. Hajnsek Examples of the potential of SAR polarimetry for quantitative bio/geo-physical parameter estimation
- approx. 17.30 **Social Event**
Guided tour through the city center of Munich (voluntary)

Wednesday, October 28, 2015
08.30 – 17.15

- 08.30 – 10.00 **Polarimetric SAR Interferometry I**
K. Papathanassiou Interferometric observables at different polarizations over natural scatters · Main principles and the basic techniques for the coherent combination
- 10.30 – 12.00 **Polarimetric SAR Interferometry II**
K. Papathanassiou Application of Pol-InSAR for model based quantitative estimation of physical parameters of different natural scatters by means of various experimental data sets
- 13.00 – 13.45 **ESA SAR missions and their exploitation**
Y.L. Desnos ERS, Envisat ASAR · Science and Applications development · Introduction to ESA sentinel 1 · Earth Explorers Biomass scientific SARs · Space Science SARs
- 14.00 – 15.30 **SAR Moving Target Techniques**
S. Baumgartner Moving target signal properties, influence on SAR imagery, position and motion parameter estimation, single- and multi-channel SAR-GMTI techniques (ATI, DPCA, STAP, ...)
- 15.45 – 17.15 **SAR-Geocoding**
A. Roth SAR inherent geometric distortions, algorithms, techniques and how these distortions can be corrected · Basics on map projection and cartography as well as different applications

Thursday, October 29, 2015
08.30 – 16.30

Applications

- 08.30 – 10.00 **Differential SAR Interferometry**
A. Ferretti Impressive precision figures from spaceborne systems · D-InSAR data examples: seismic fault, landslide, volcano, subsidence, monitoring individual buildings and structures

10.30 – 12.00
H. Rott

Glaciology

Basics of radar backscattering of snow and ice · InSAR and image correlation techniques for ice motion mapping · Applications of SAR for ice flow dynamics and mass balance of glaciers and ice sheets

13.00 – 14.30
S. Lehner

Oceanography

Theoretical aspects and practical applications · Latest results on interferometric measurements of waves and ocean currents for coastal applications

15.00 – 16.30
G. De Grandi

Vegetation and Classification

Continental Scale Forest Mapping Using Radar Data: Selected Topics

Friday, October 30, 2015
08.30 – 12.30

Satellite Concepts and DLR Airborne SAR Activities

08.30 – 10.30
G. Krieger

Innovative SAR Missions and Sensor Concepts

Capabilities and limitations of present-day spaceborne SAR systems and missions · New concepts for high-resolution wide-swath SAR imaging · Bistatic and multistatic SAR · TanDEM-X

11.00 – 12.30
R. Horn

DLR Airborne SAR Activities

System presentation, capabilities and results

Additional Courses

- „Radar Signal Processing: Fundamentals, Applications, and Advanced Topics“, 22.–26.6.2015 (Code SE 2.08)
- „Passive und multistatische Radare“, 17.–18.11.2015 (Code SE 43)
- „Automotive und industrielle Radarsensoren“, 2.–4.12.2015 (Code SE 2.45)

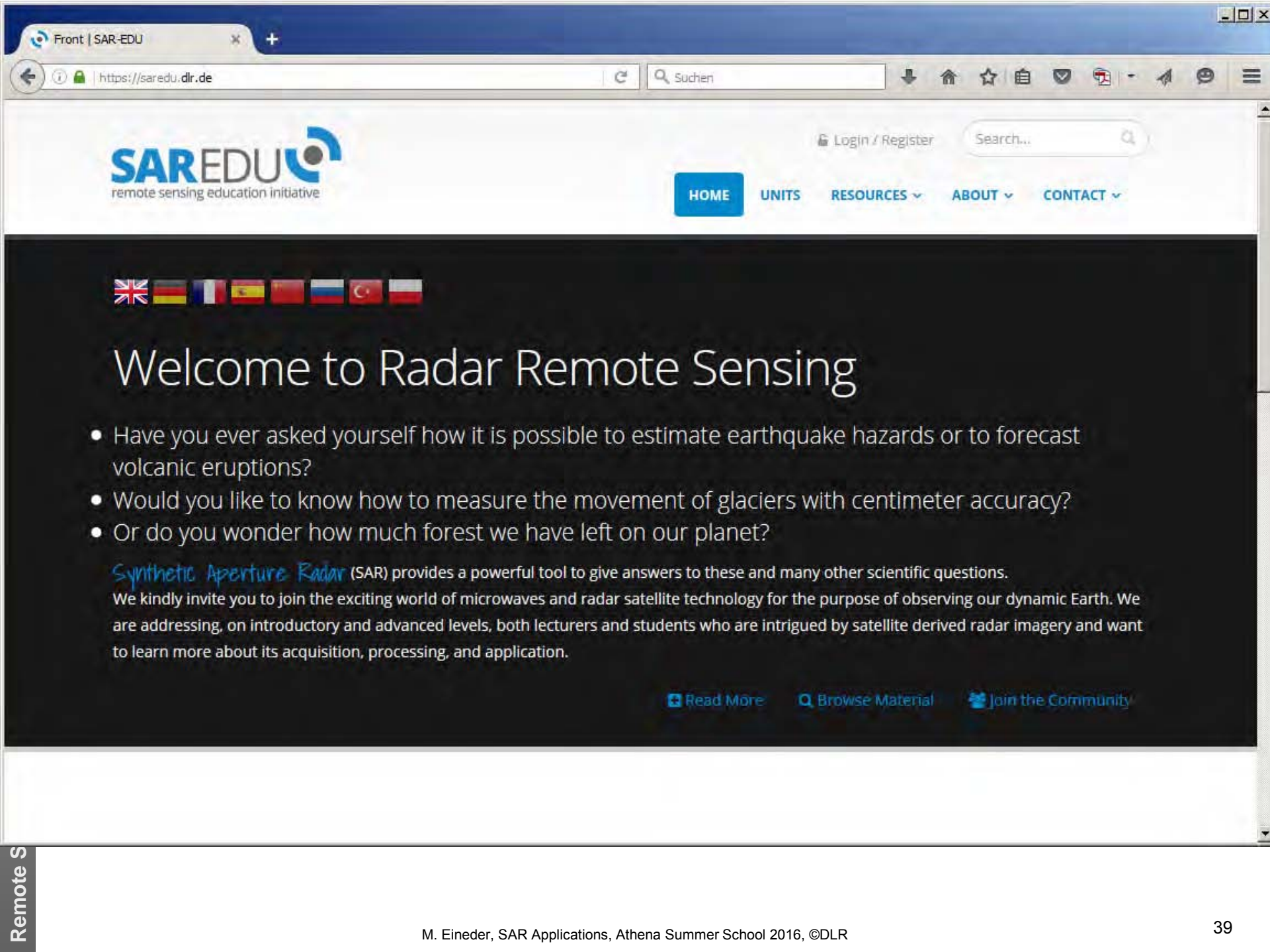

Welcome to Radar Remote Sensing

- Have you ever asked yourself how it is possible to estimate earthquake hazards or to forecast volcanic eruptions?
- Would you like to know how to measure the movement of glaciers with centimeter accuracy?
- Or do you wonder how much forest we have left on our planet?

Synthetic Aperture Radar (SAR) provides a powerful tool to give answers to these and many other scientific questions.

We kindly invite you to join the exciting world of microwaves and radar satellite technology for the purpose of observing our dynamic Earth. We are addressing, on introductory and advanced levels, both lecturers and students who are intrigued by satellite derived radar imagery and want to learn more about its acquisition, processing, and application.

[Read More](#)

[Browse Material](#)

[Join the Community](#)

Units | SAR-EDU

https://saredu.dlr.de/unit

SAREDU

HOME UNITS RESOURCES ABOUT CONTACT

MATHEMATICS

lesson #1101

15 Dec, 2014
TUM
6.75
no comments

TIME & FREQUENCY

lesson #1102

15 Dec, 2014
TUM
6.5
no comments

FILTER & ALIASING

lesson #1103

15 Dec, 2014
TUM
6.5
no comments

RADAR PHYSICS

lesson #1104

15 Dec, 2014
TUM
4.0
2 comments

ESTIMATION THEORY

lesson #1105

15 Dec, 2014
TUM
4.0
no comments

PROBABILITY THEORY

lesson #1106

15 Dec, 2014
TUM
no ratings
no comments

DETECTION

lesson #1107

15 Dec, 2014
TUM
no ratings
no comments

PARAMETER ESTIMATION

lesson #1108

15 Dec, 2014
TUM
no ratings
no comments

OPTIMAL LINEAR ESTIMATION

lesson #1109

15 Dec, 2014
TUM
1.0
no comments

STEFAN AUER: MATHEMATIK

talk #1110

10 Dec, 2014
TUM
7.5
2 comments

INTRODUCTION TO NEST

tutorial #1201

15 Dec, 2014
PSU
8.5
no comments

INTRODUCTION TO SARScape

tutorial #1202

18 Dec, 2014
PSU
8.5
0 comments

https://saredu.dlr.de/unit/parameter



IV. SAR-EDU Sommerschule zur angewandten Radarfernerkundung

„Exploring SAR data“



[mehr Infos](#)

[Jetzt Bewerben](#)



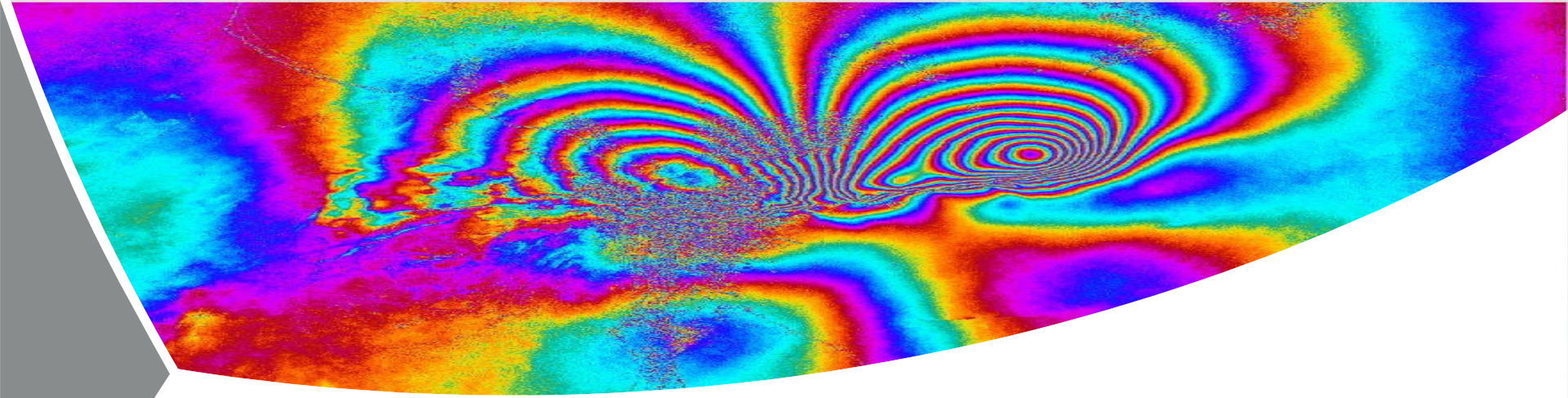

Athena Summer School – SAR SAR Interferometry – Basics May 2016

Material:

Michael Eineder, Richard Bamler

Remote Sensing Technology (TUM/DLR)

Content of SAR Interferometry

- Basics
- Error sources

Educational Objectives

- Understand the SAR interferometry (InSAR) principle
- Know the most important InSAR applications
- Learn about phase ambiguity problem and phase unwrapping techniques

Further Reading

Books

- Hanssen, R. F. (2001). *Radar Interferometry: Data Interpretation and Error Analysis* (Remote Sensing and Digital Image Processing Series, Vol. 2). Dordrecht: Springer Netherlands.
- Kampes, B. M. (2006). *Radar Interferometry: Persistent Scatterer Technique*. (Remote Sensing and Digital Image Processing Series, Vol. 12). Dordrecht: Springer Netherlands.

Papers

- Bamler, R., & Hartl, P. (1998). Synthetic aperture radar interferometry. *Inverse Problems*, 14, R1-R54.
- Rosen, P., Hensley, S., Joughin, I. R., Li, F. K., Madsen, S. N., Rodriguez, E., & Goldstein, R. M. (2000). Synthetic Aperture Radar Interferometry. *Proceedings of the IEEE*, 88(3): 333-382.

Structure

- First milestones of SAR interferometry
- Interferogram formation
- Techniques
- InSAR data processing sequence
- Phase unwrapping
- InSAR satellites and examples

Structure

- First milestones of SAR interferometry
- Interferogram formation
- Techniques
- InSAR data processing sequence
- Phase unwrapping
- InSAR satellites and examples

First milestones of SAR interferometry (=InSAR)



Graham, Synthetic Interferometer Radar for Topographic Mapping, Proceedings of the IEEE, vol. 62 no. 6, 1974.

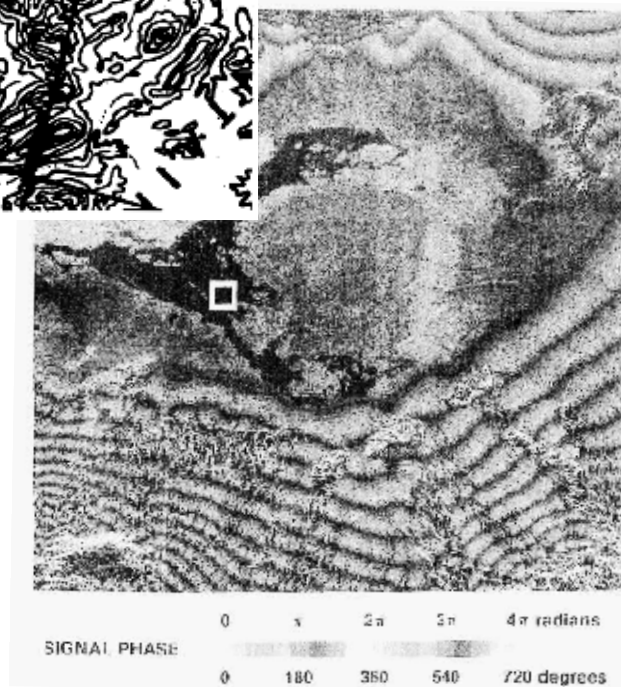

Goldstein et al., Satellite radar interferometry: Two-dimensional phase unwrapping, Radio Science, vol. 23, no. 4, 1988.

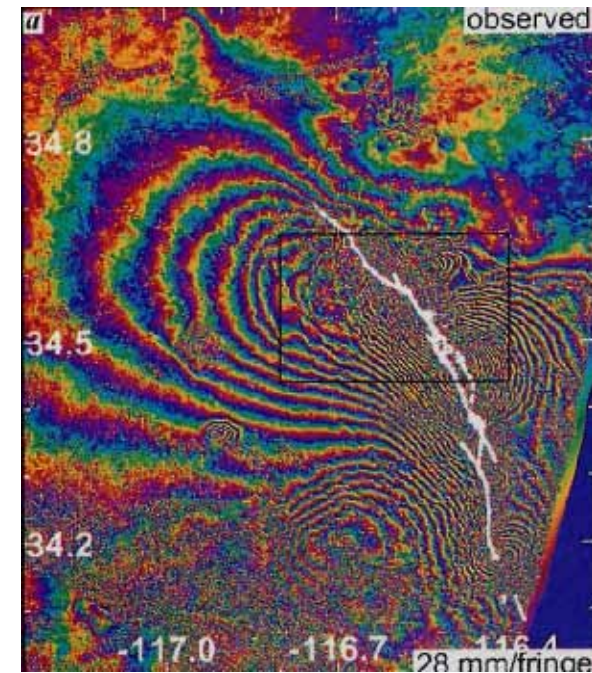

Massonnet et al., The displacement field of the Landers earthquake mapped by radar interferometry, Nature 364, 1993.

Structure

- First milestones of SAR interferometry
- Interferogram formation
- Techniques
- InSAR data processing sequence
- Phase unwrapping
- InSAR satellites and examples

Phase of a Pixel in a SAR Image

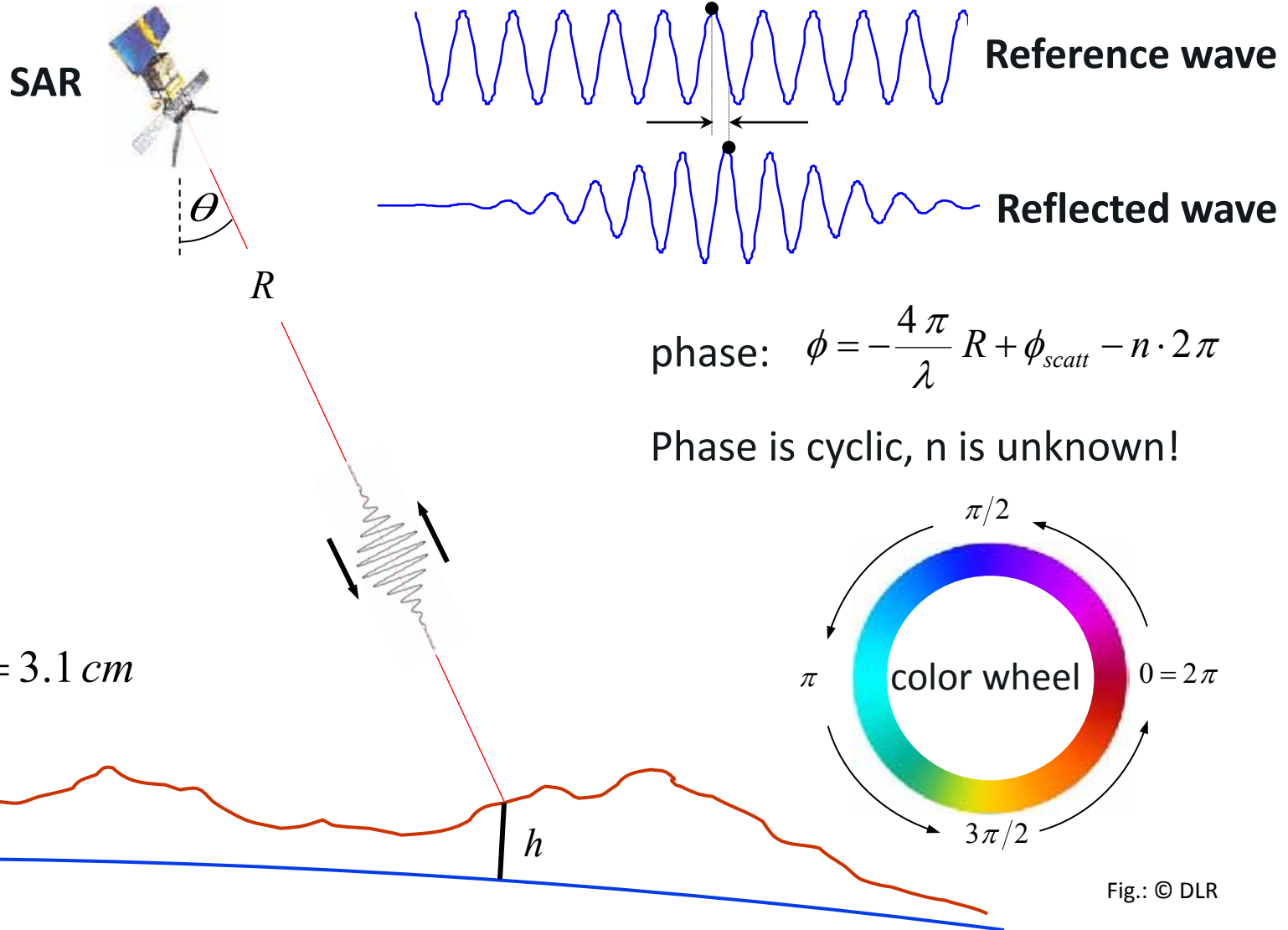
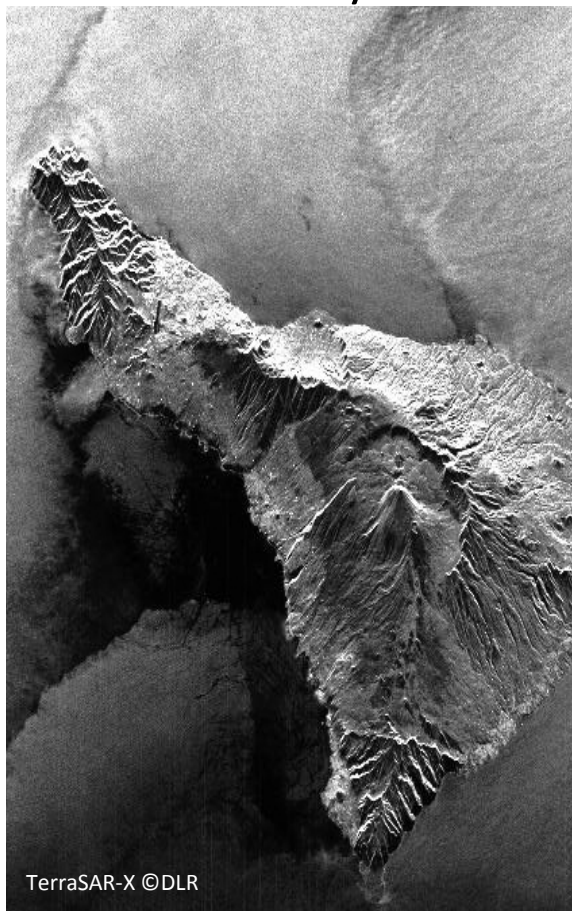

Fig.: © DLR

A complex SAR image can be decomposed into ...

Intensity



and

Phase

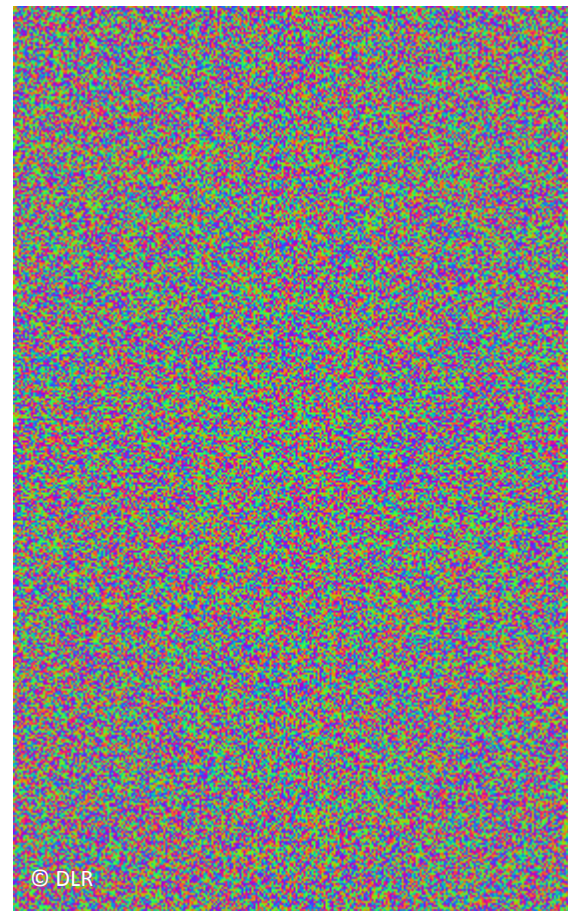

SAR Interferogram Formation

phase of a complex SAR image pixel: $\phi_i = -\overbrace{\frac{4\pi}{\lambda} R_i}^{\text{range}} + \overbrace{\phi_{scatt,i}}^{\text{scattering}}$ note: non-ambiguous phase!

complex SAR image #1: $u_1[i, k] = |u_1[i, k]| \cdot \exp(j \phi_1[i, k])$

complex SAR image #2: $u_2[i, k] = |u_2[i, k]| \cdot \exp(j \phi_2[i, k])$

interferogram: $v[i, k] = u_1[\cdot] u_2^*[\cdot] = |u_1[\cdot]| |u_2[\cdot]| \exp(j \phi[\cdot])$

interferometric phase: $\phi[\cdot] = \phi_1[\cdot] - \phi_2[\cdot]$

Structure

- First milestones of SAR interferometry
- Interferogram formation
- **Techniques**
- InSAR data processing sequence
- Phase unwrapping
- InSAR satellites and examples

Across-Track Interferometry - Digital Elevation Models

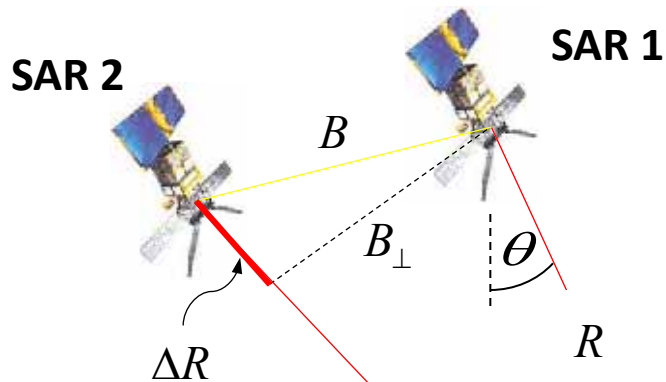

Phase of a Pixel in ...

$$\dots \text{ SAR-Image \#1: } \phi_1 = -\frac{4\pi}{\lambda} R + \phi_{scatt,1}$$

$$\dots \text{ SAR-Image \#2: } \phi_2 = -\frac{4\pi}{\lambda} (R + \Delta R) + \phi_{scatt,2}$$

$$\dots \text{ Interferogram: } \phi = \phi_1 - \phi_2 = \frac{4\pi}{\lambda} \Delta R$$

↑

(if $\phi_{scatt,1} = \phi_{scatt,2}$!)

X-band: $\lambda = 3.1 \text{ cm}$

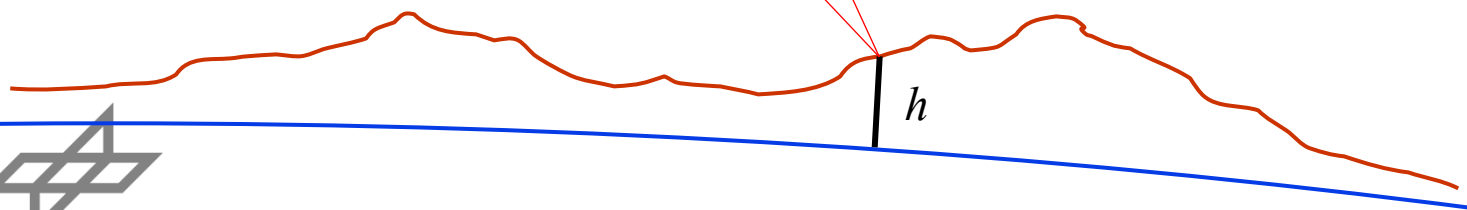
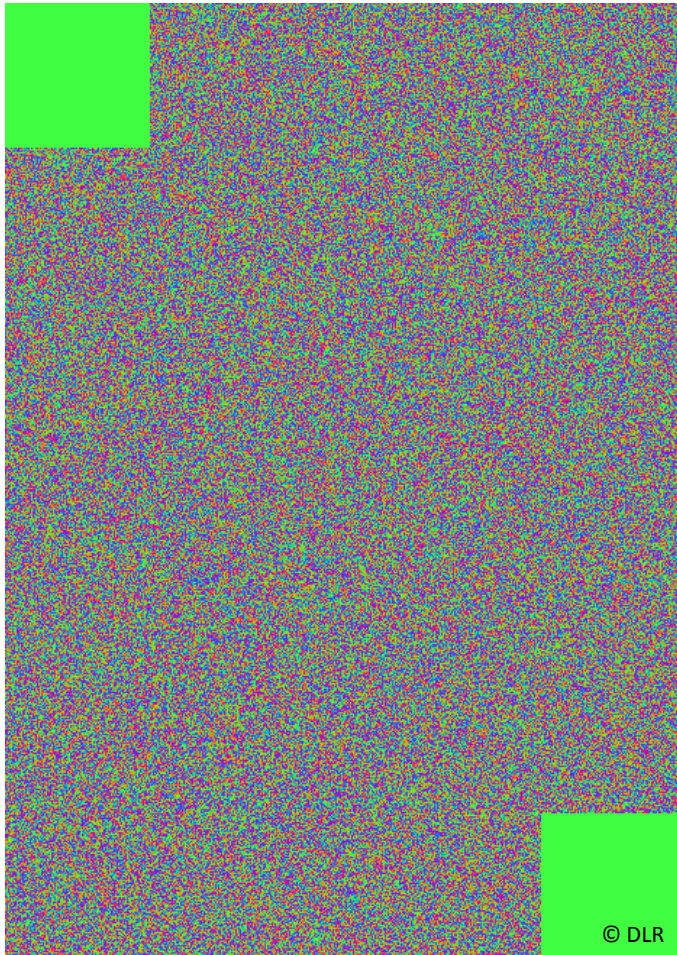

Fig.: © DLR

Phase Difference of Two SAR Images



Phase in one SAR image looks random (→speckle effect!).
Only after accurate co-registration the phase difference reveals the interferogram.

(Video Animation)



ERS SAR Image

Bachu, China

approx. 100 km × 80 km

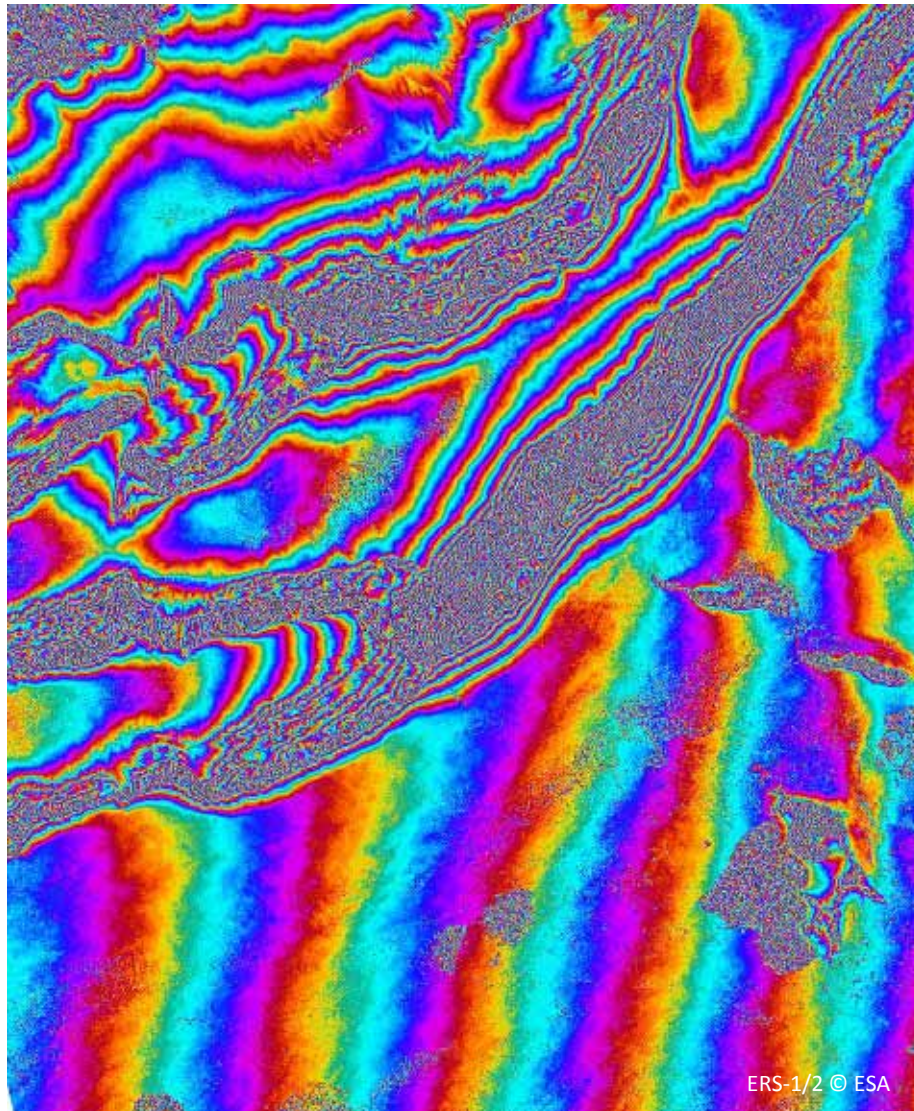

Interferometric Phase

Bachu, China

approx. 100 km × 80 km

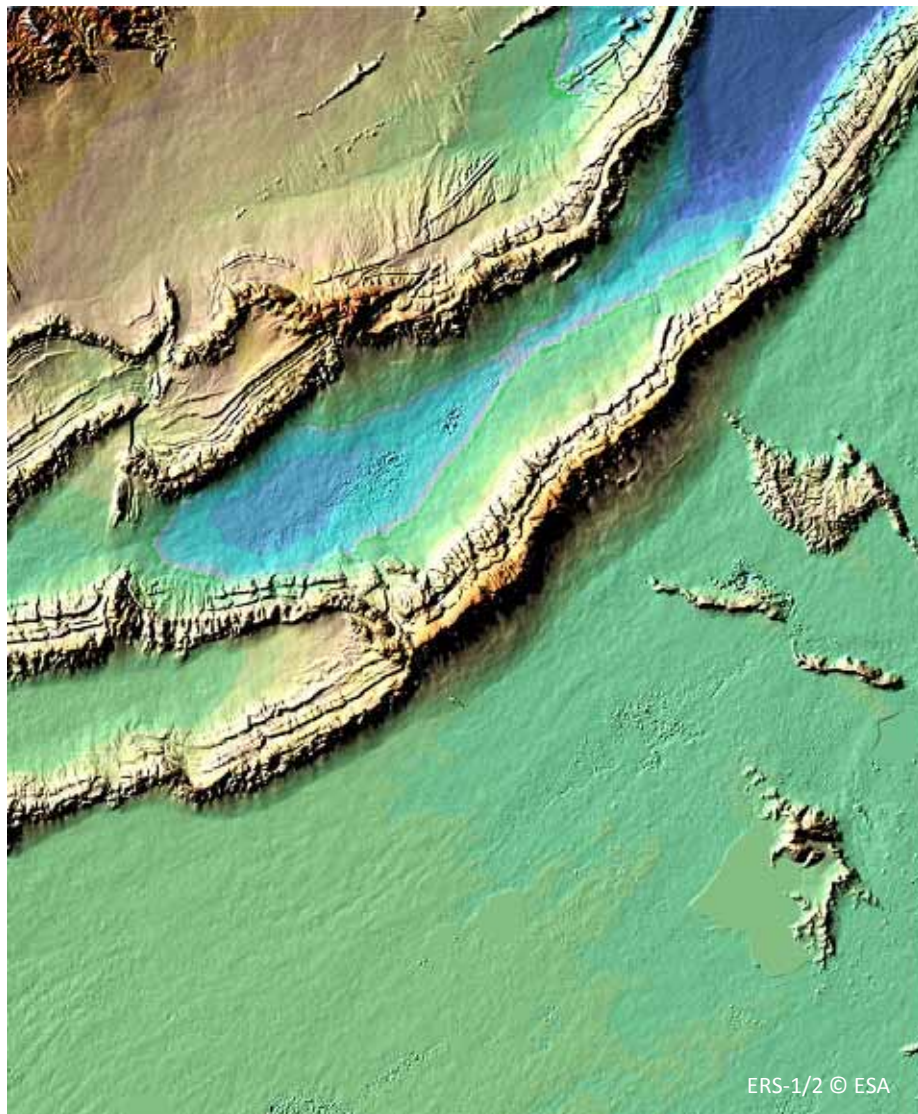

InSAR DEM (ERS-1/2)

Bachu, China

approx. 100 km × 80 km

Interferometric Sensitivity as a Function of Wavelength

$$\phi = \phi_1 - \phi_2 = \frac{4\pi}{\lambda} \Delta R$$

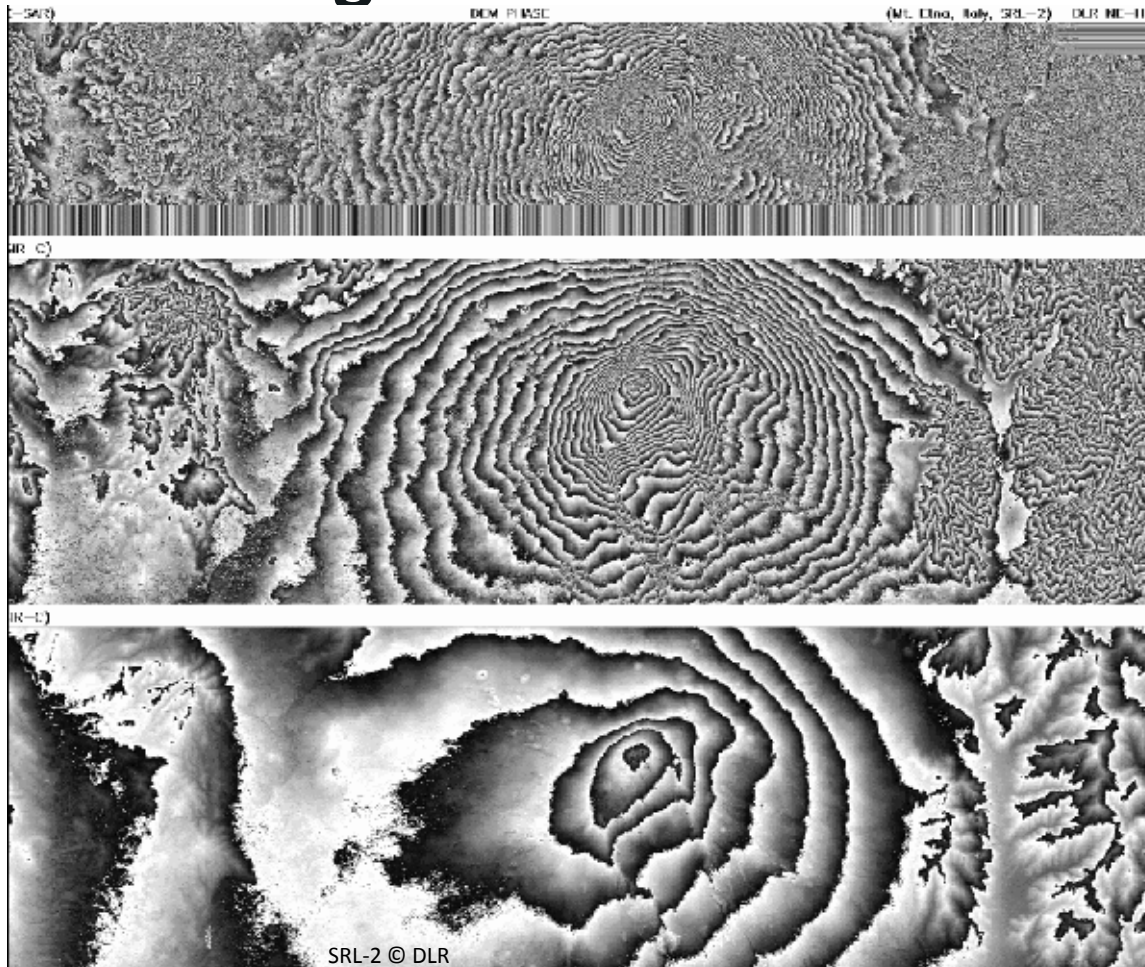

X-band

C-band

L-band

Fig.: Mt. Etna
data: SRL-2 (© DLR)

Differential Interferometry

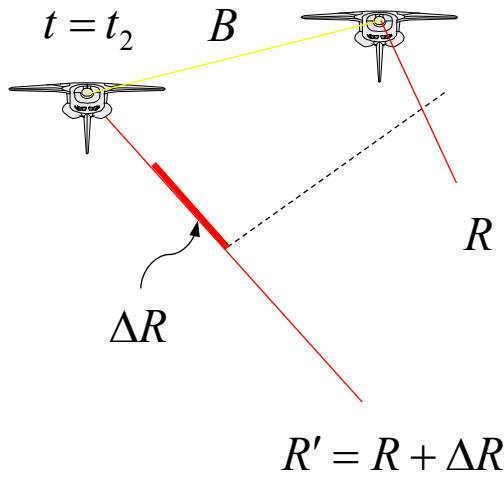
 $t = t_1$

Interferometric phase:

$$\phi = \phi_{topo}(z; B) + \phi_{diff}$$

$$\phi_{diff} = \frac{4\pi}{\lambda} \Delta R_{diff}$$

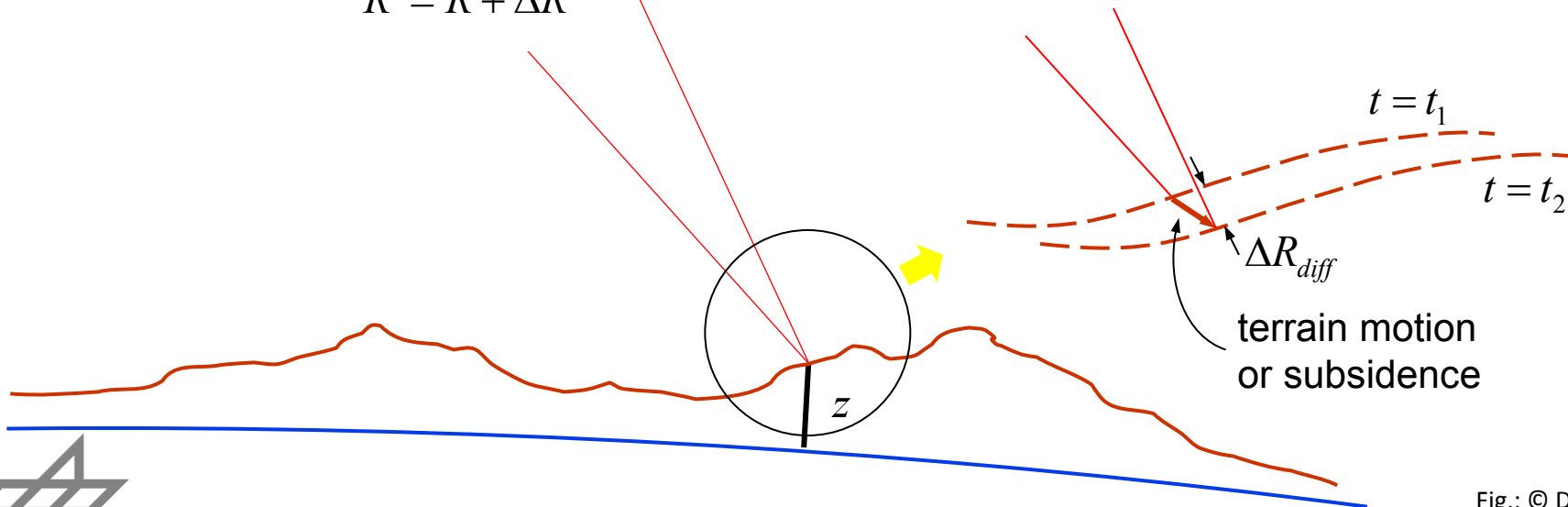
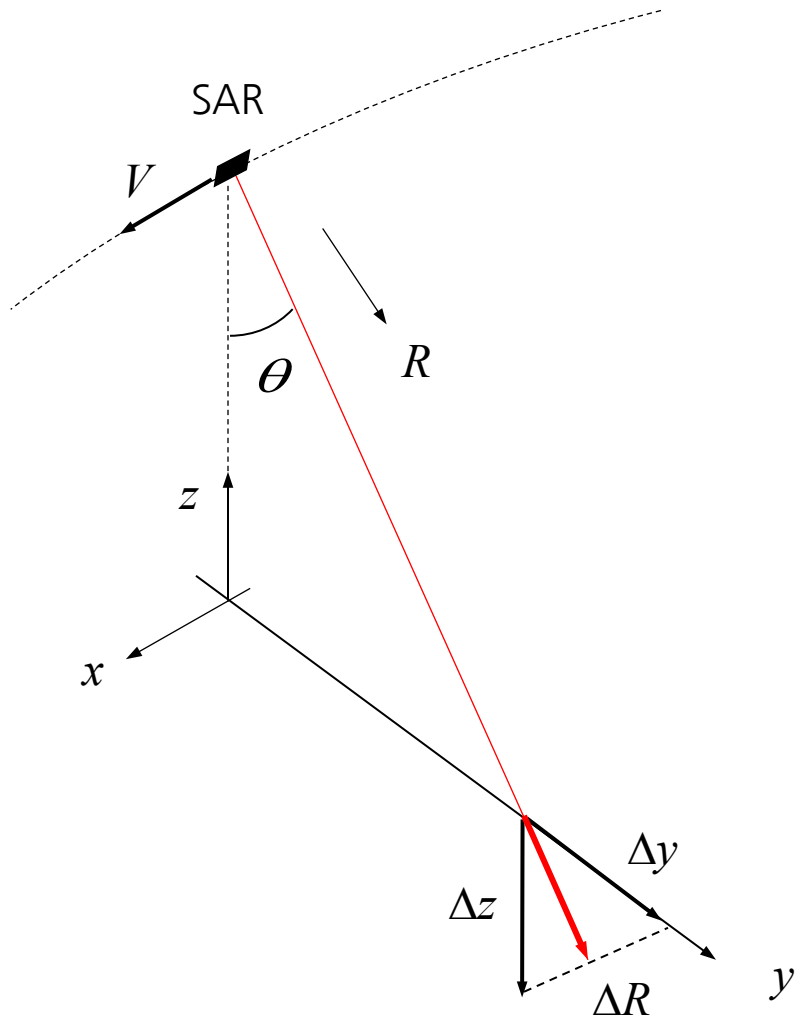

Fig.: © DLR

Sensitivity for Displacement



$$\Delta R = \Delta y \sin \theta - \Delta z \cos \theta$$

for ERS ($\theta = 23^\circ$):

1 fringe (2π) corresponds to

2.8 cm in R ($\lambda/2$)

3.0 cm in z (e.g. subsidence)

7.2 cm in y (horizontal motion)

Coseismic Deformation of Bam Earthquake 26 Dec 2003

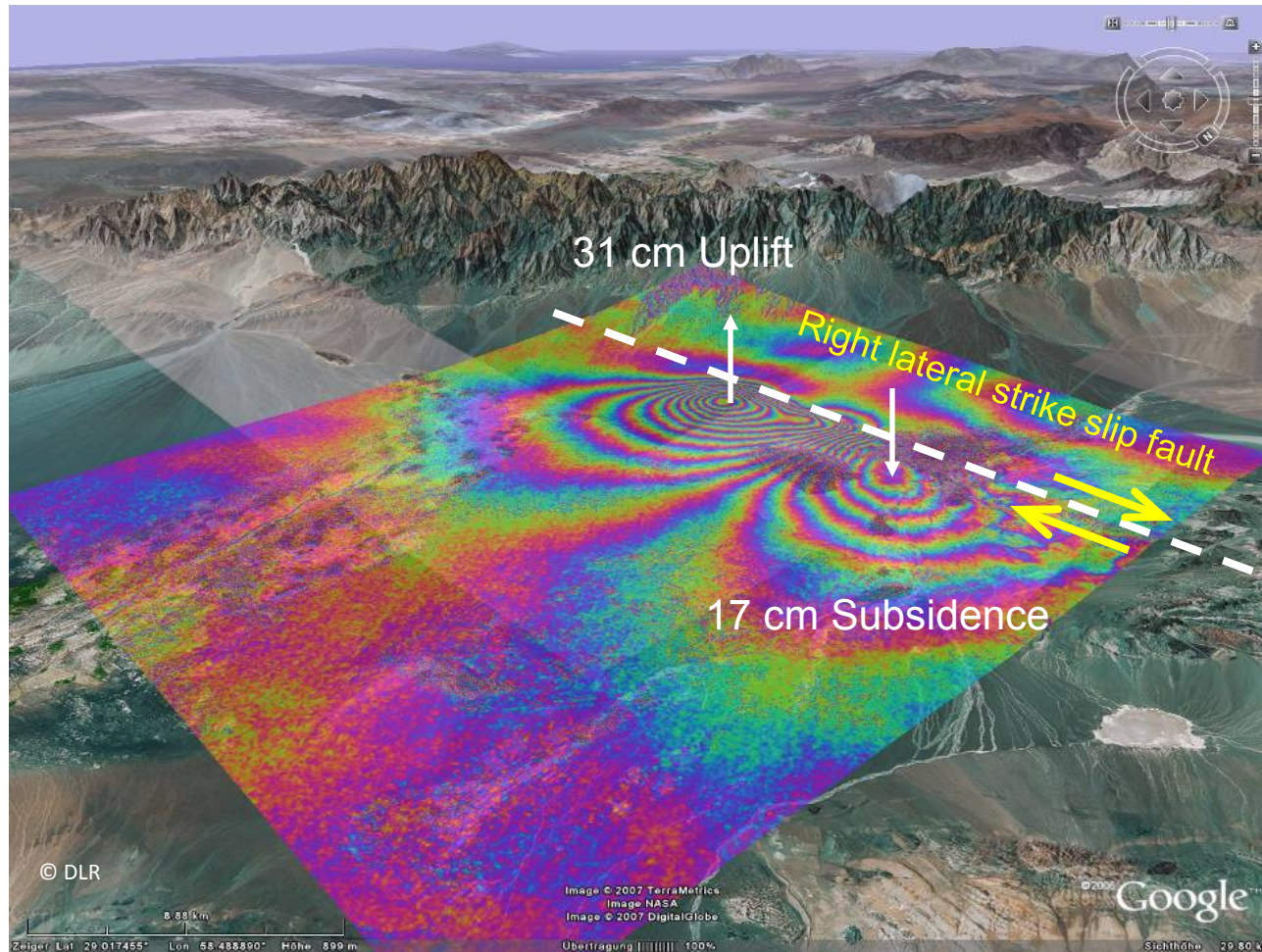

Monitoring of Landslides by D-InSAR



La Valette/South France

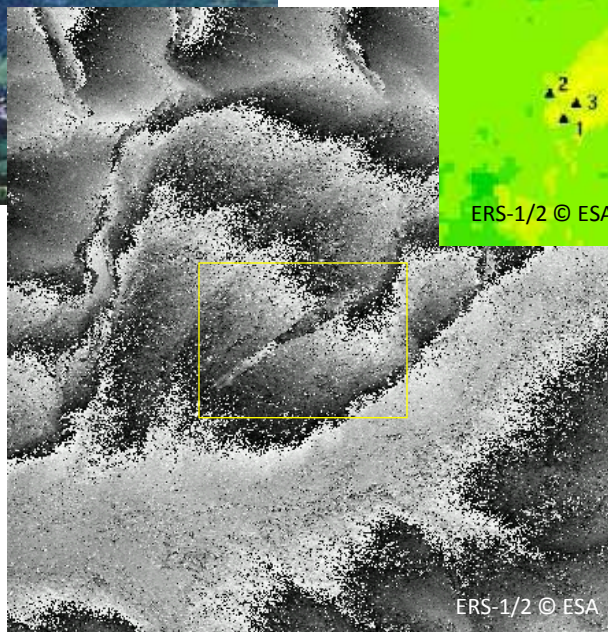

Interferogram

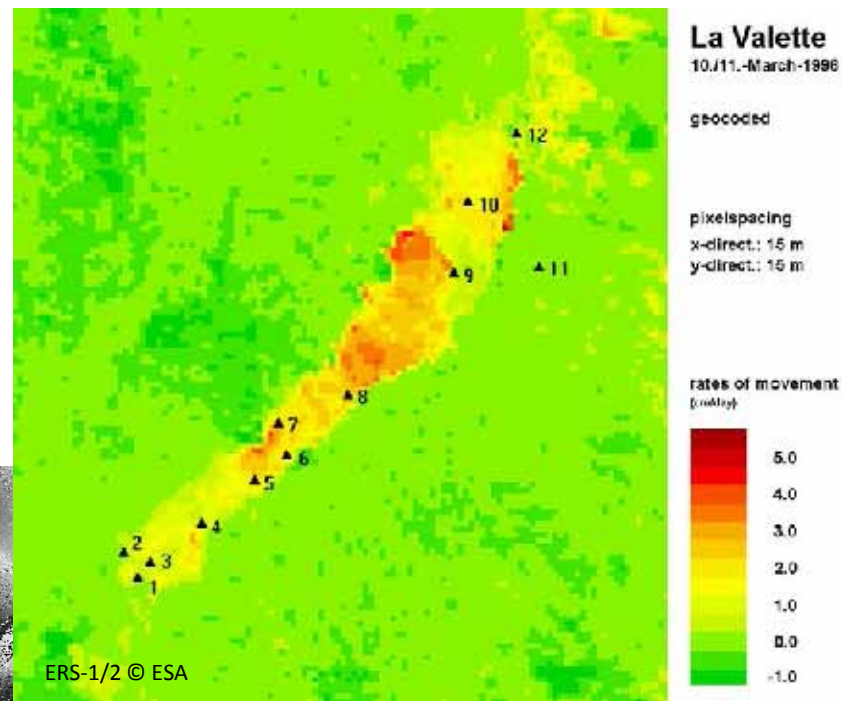

Motion map after removal of topographic phase

(Vietmeier, 2000)
Data: ERS-1/2, ©ESA

Glacier Flow Field Derived from D-InSAR

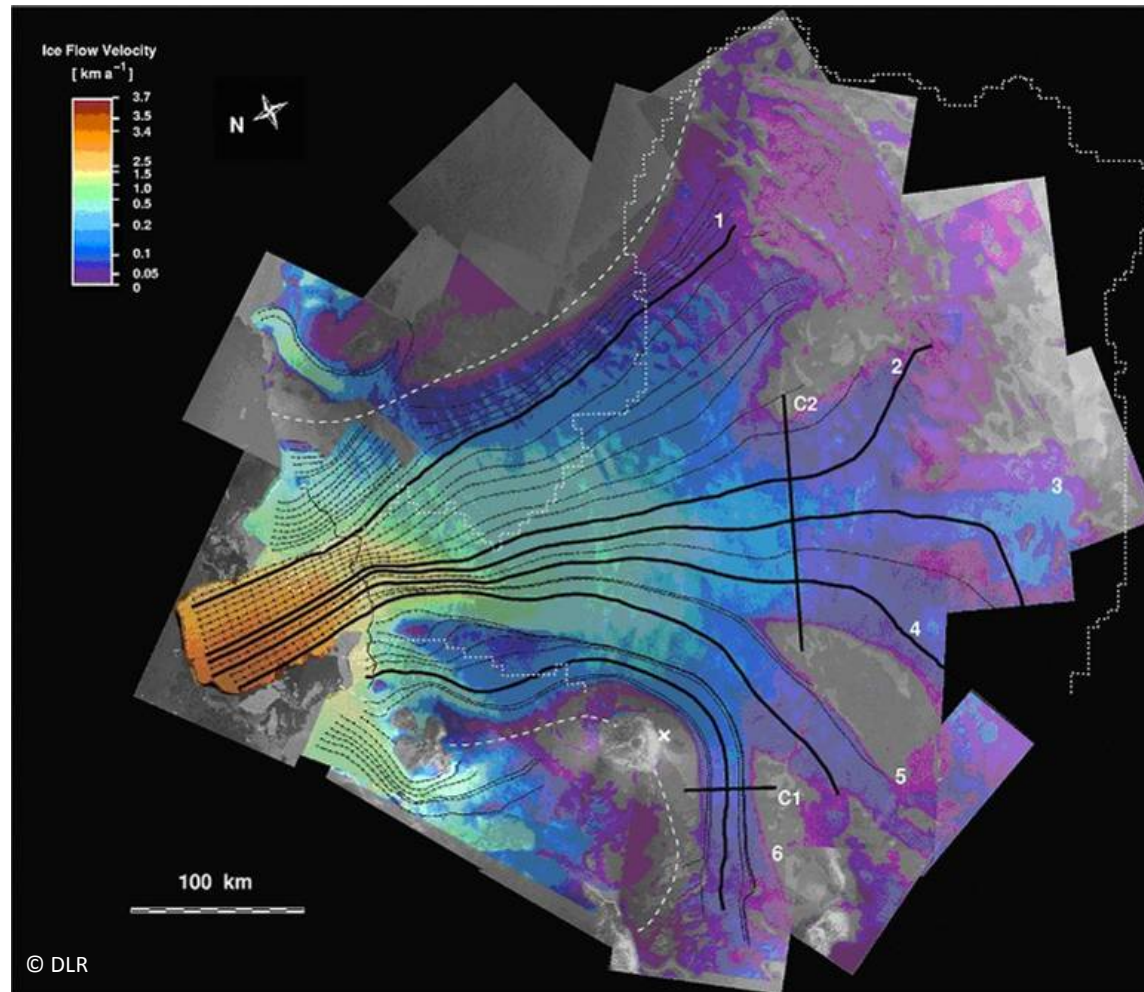

Antarctic
Thwaites
glacier
Data: ERS-1/2,
©ESA

approx.
500 km x 500 km

(Lang et al., 2004)

Along Track Interferometry (ATI)

- Use of two antennas at different along track positions
 - ➔ images taken at different times $\Delta t = \Delta x / (2v)$
 - ➔ range component v_r of ground motion causes phase difference between antennas: $\Delta \phi = 2\pi \Delta t * v_r * / \lambda$
- Examples: SRTM antenna displacement or TerraSAR-X in Dual Receive Mode

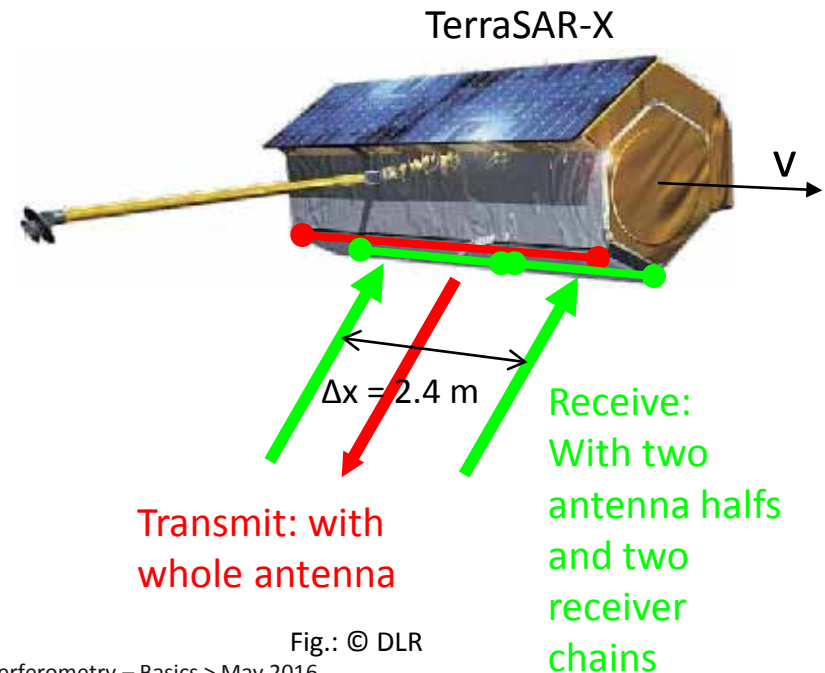
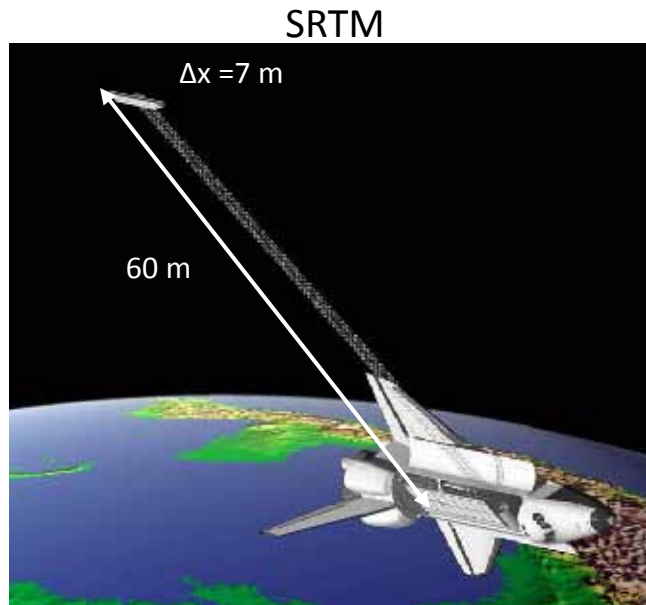
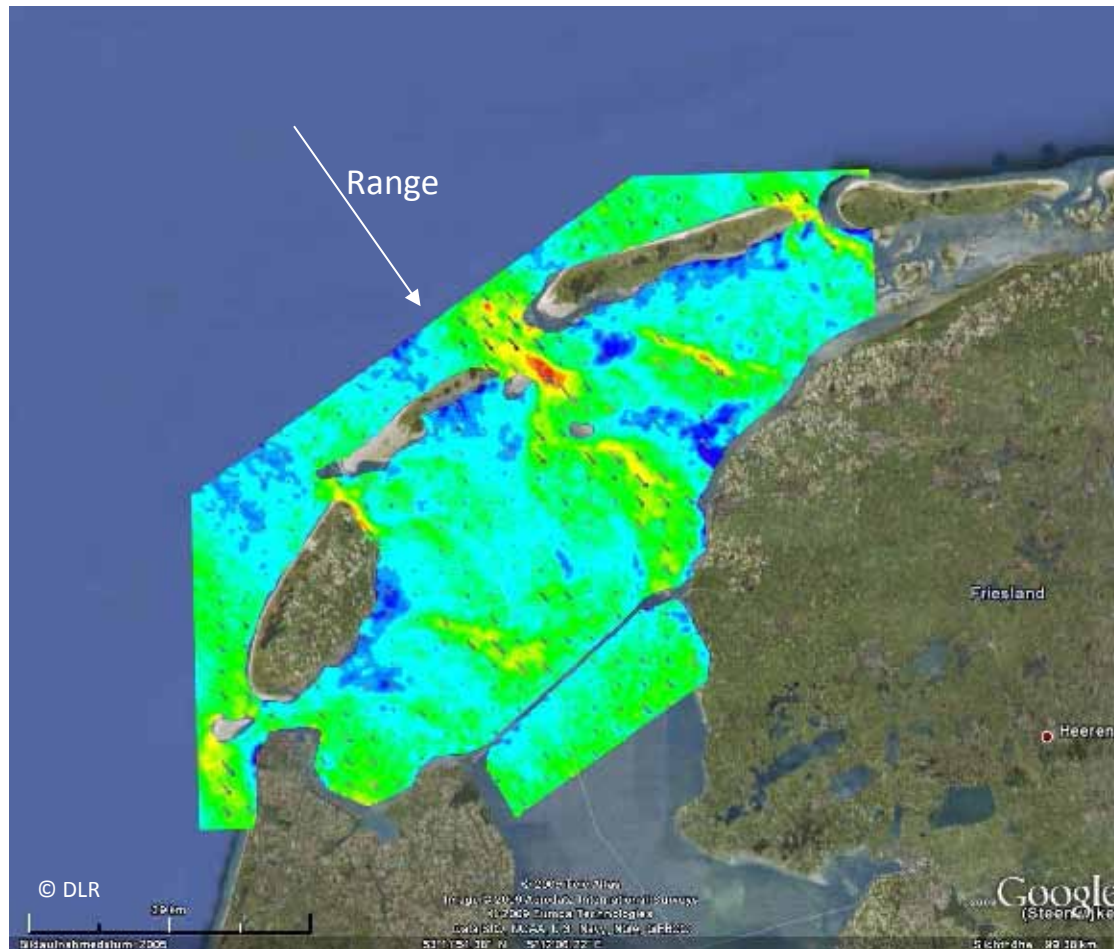

Fig.: © DLR

Tidal Currents Measured by SRTM/X-SAR ATI



Dutch Wadden Sea
3:16 hours
before high tide

radial velocity

-0.8 m/s + 1.2 m/s

(Romeiser et al., 2003)

Along Track Interferometry (ATI) ($\Delta t = \text{ms}$)

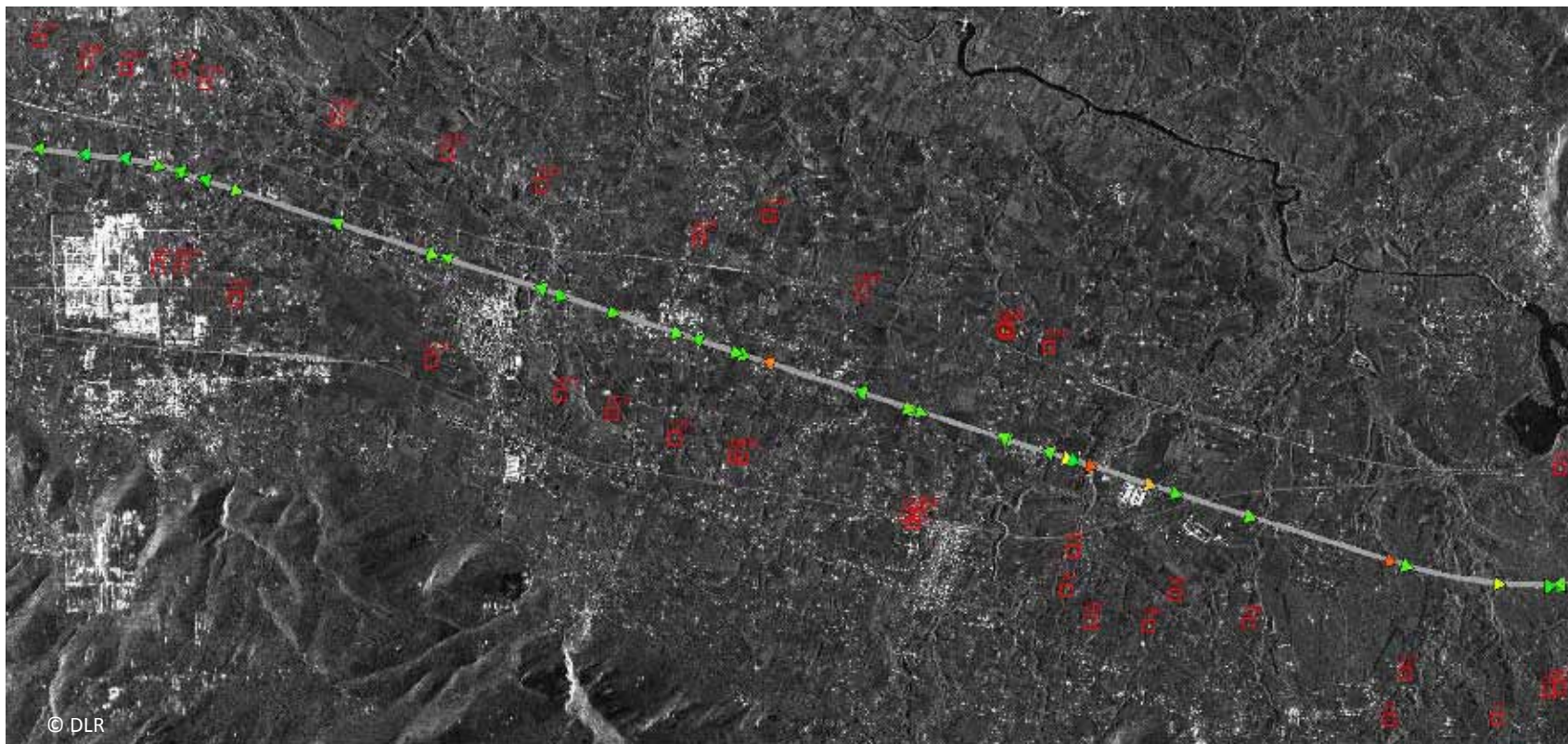

Vehicle velocity estimation using along track phase difference and azimuth displacement („train off the track effect“).

Example: Autostrada del Sole south of Rome (Suchandt, 2008). Data: TerraSAR-X.

Summary: SAR Interferometry ...

... combines two or more complex-valued SAR images to derive geometric information about the imaged objects (compared to using a single image) by exploiting **phase differences**.

⇒ Images must differ in at least one aspect (= “baseline”)

baseline type	known as ...	applications: measurement of ...
$\Delta\theta$	across-track	topography, DEMs
$\Delta t = \text{ms to s}$	along-track	ocean currents, moving object detection, MTI
$\Delta t = \text{days}$	differential	glacier/ice fields/lava flows, Snow Water Equivalent (SWE), hydrology
$\Delta t = \text{days to years}$	differential	subsidence, seismic events volcanic activities, crustal displacements
$\Delta t = \text{ms to years}$	coherence estimator	sea surface decorrelation times land cover classification

Structure

- First milestones of SAR interferometry
- Interferogram formation
- Techniques
- InSAR data processing sequence
- Phase unwrapping
- InSAR satellites and examples

InSAR Processing - Data Selection (I)

- Select two (or more) single-look complex SAR images according to application:
 - Usually repeat pass, i.e.
 - Same orbital track, same incidence angle, same mode, same polarization
 - Different time, different position (baseline)

- Apply spectral (wavenumber) shift filtering (see later)

InSAR Processing - Coregistration (II)

➤ Reasons for misregistration:

- Parallel baseline B_{\parallel} → relative image shift
- Divergent orbits → image rotation (mostly negligible)
- Orthogonal baseline B_{\perp} → range stretch due to flat Earth and topography

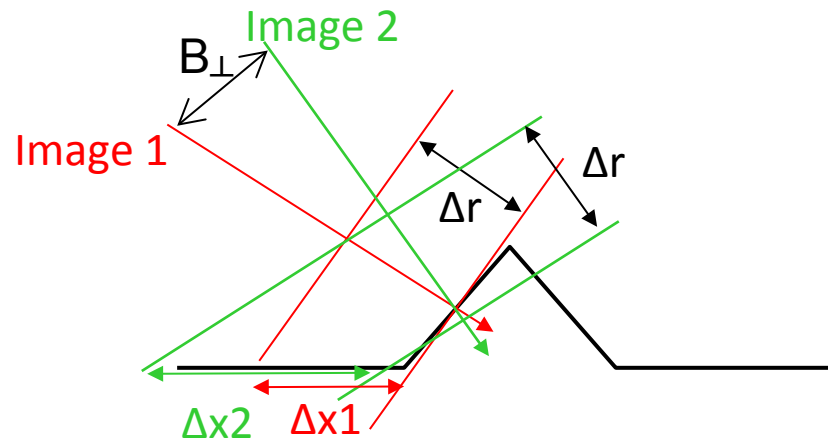

Fig.: © DLR

InSAR Processing - Coregistration (III)

- **Determine co-registration parameters:**
 - Cross-correlate >100 image chips spread over image
 - A-priori shift parameters can be calculated from annotation (orbit, timing) and a DEM
 - Use over-sampling and interpolation to locate correlation peaks
 - Apply regression to parameterize co-registration (e.g. affine transform)

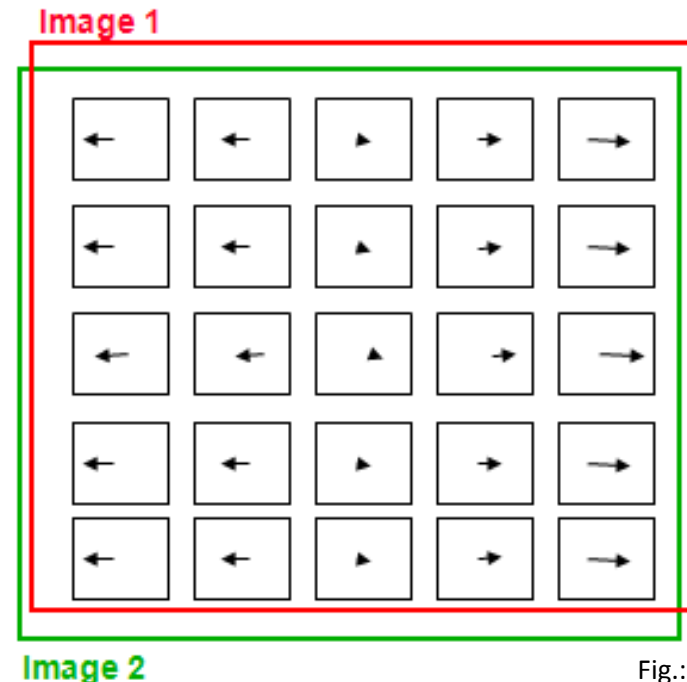

Fig.: © DLR

InSAR Processing - Resampling (IV)

➤ Co-register images:

- Resample slave image(s) to match master image
- Required accuracy: $\ll 1/10$ resolution element for low squint-case
- 4 point cubic (or better) to minimize interpolation errors
- Interpolation in azimuth requires *band-pass* interpolator in case of non-zero Doppler centroid frequency
- Effect of mis-registration $\delta R, \delta t$: $\delta\phi = 2\pi f_{DC} \delta t$
 - loss of coherence
 - phase bias in high squint case:

InSAR Processing – Interferogram (V)

- Form interferogram(s) by taking local average; estimate local coherence
- Simulate phase of flat Earth or available (even coarse) DEM and subtract from interferogram
- Reduce phase noise by low-pass filtering of interferogram (e.g. by averaging of adjacent samples)
- Derive local quality measures to support phase unwrapping (**coherence**, slope estimates, lay-over probability, ...)

InSAR Processing – Interferogram Formation

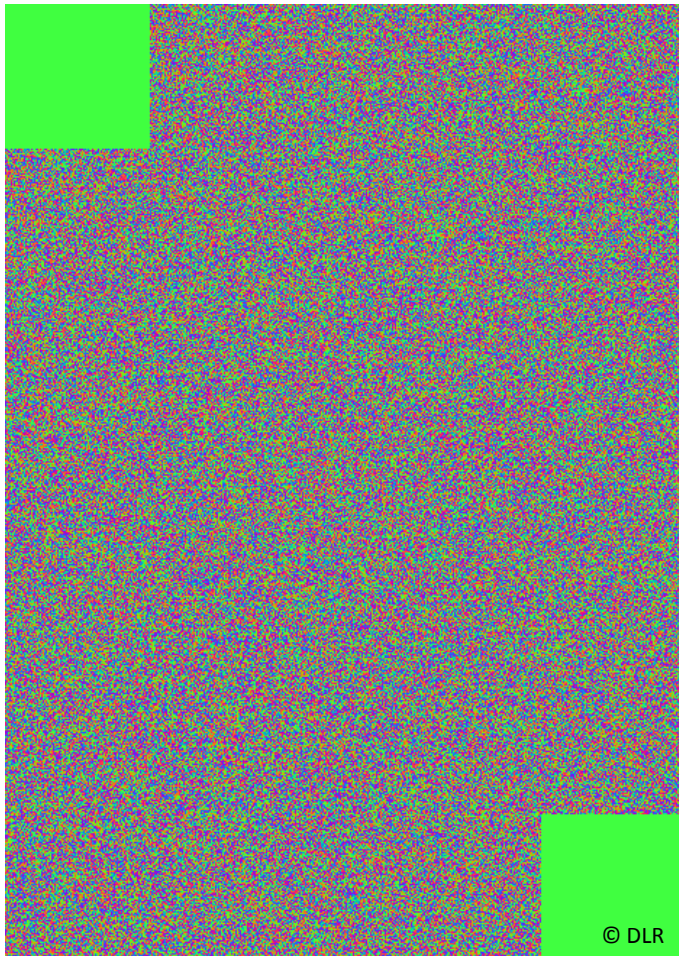

Phase in one SAR image looks random (→speckle effect!).
Only after accurate co-registration the phase difference reveals the interferogram.

(Video Animation)

Coherence - A Measure of Interferogram Quality

- Normalized Correlation coefficient between the two complex SAR images u_1 u_2

$$\gamma = \frac{E\{u_1 u_2^*\}}{\sqrt{E\{|u_1|^2\}} E\{|u_2|^2\}}$$

- Coherence estimate:

$$|\hat{\gamma}[i,k]| = \frac{\left| \sum_W u_1[i,k] u_2^*[i,k] \right|}{\sqrt{\sum_W |u_1[i,k]|^2 \sum_W |u_2[i,k]|^2}}$$

W : small window centered around pixel $[i,k]$

Typical window size: 5 – 100 pixels

Stationarity within window assumed!

Typical InSAR Processing Sequence (VI)

- **Apply phase unwrapping**
- Add flat Earth phase to obtain absolute phase
- Use ground control points (GCPs) to improve orbit and baseline

Typical InSAR Processing Sequence (VII)

- Compute DEM in map projection by geo-coding pixels from satellite range/azimuth geometry

Options:

- Forward mapping:
 - Compute 3-D co-ordinates of every interferogram pixel
 - Interpolate the resulting 3-D irregular point cloud to a regular grid
- Backward mapping:
 - Start from regular ground grid in desired co-ordinate system
 - Increase height of every ground grid point until it matches range and phase of an interferogram pixel (interpolation in interferogram required)

Structure

- First milestones of SAR interferometry
- Interferogram formation
- Techniques
- InSAR data processing sequence
- **Phase unwrapping**
- InSAR satellites and examples

Interferometric Phase is Ambiguous

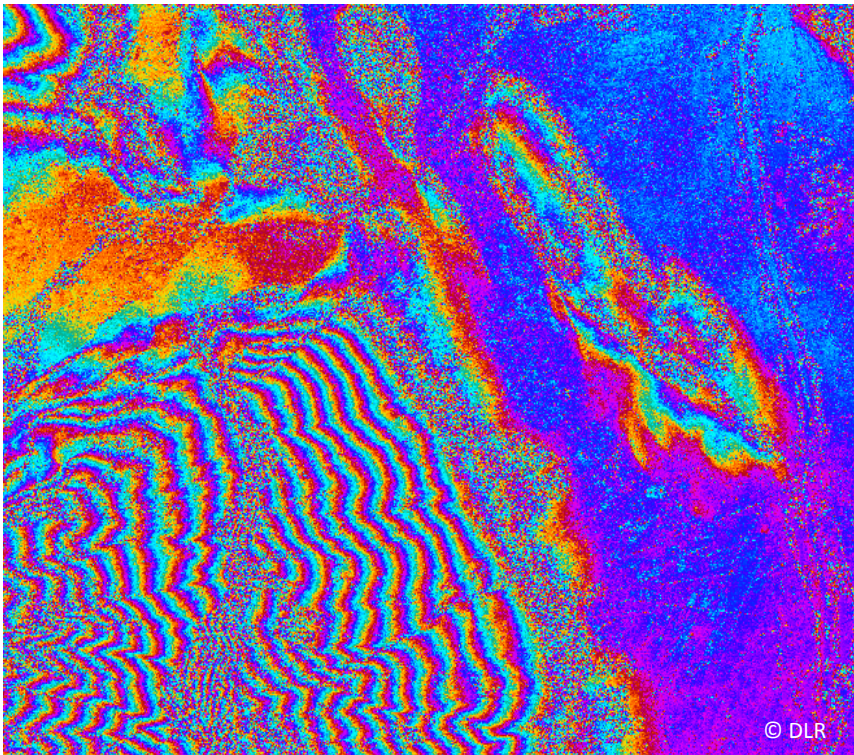

good fringe quality

ERS-1/2, 13/14 Jan. 1996

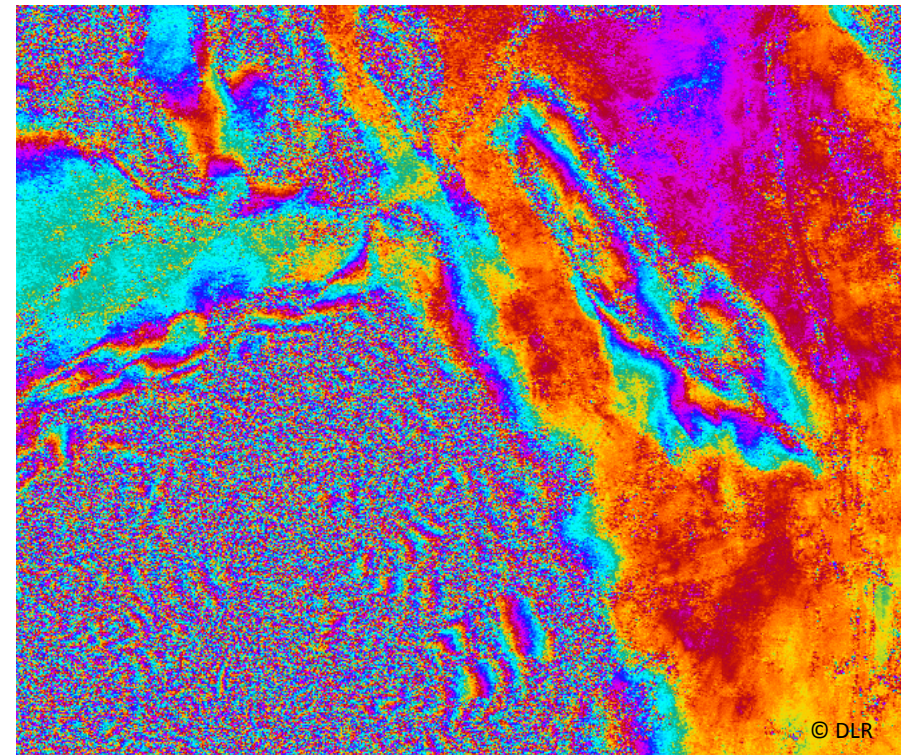

bad fringe quality

ERS-1/2, 23/24 March 1996

Intro: 2D Wrapping Problem (I)

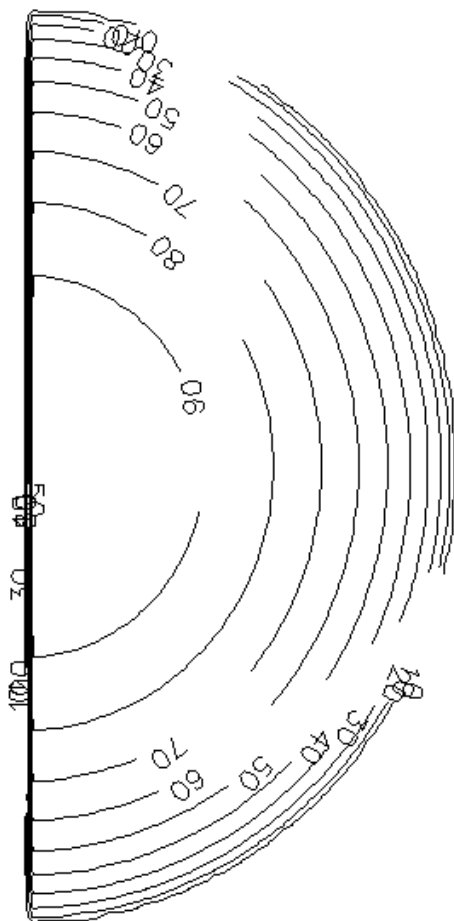

Reality: a Half-Dome Mountain

Contour plot of heights

Fig.: © DLR

Intro: 2D Wrapping Problem (II)

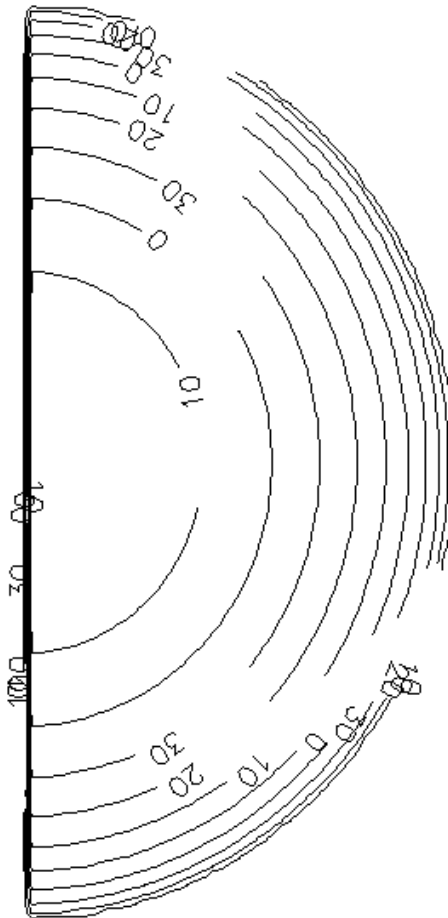

InSAR phase is wrapped!

→ proportional to wrapped height

How to reconstruct absolute heights from that?

Intro: 2D Wrapping Problem (III)

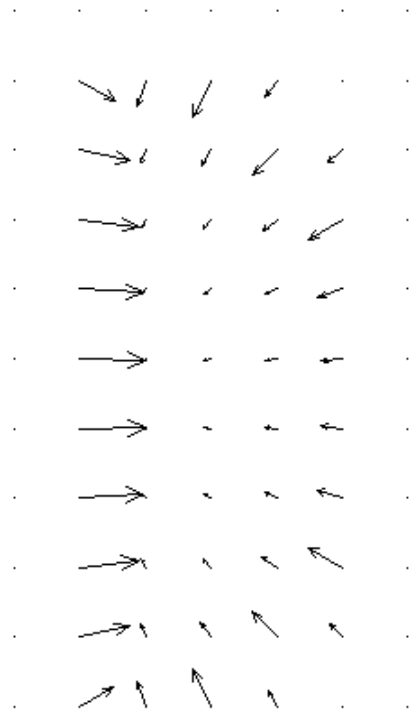

Key: gradient field of original heights

Fig.: © DLR

Intro: 2D Wrapping Problem (IV)

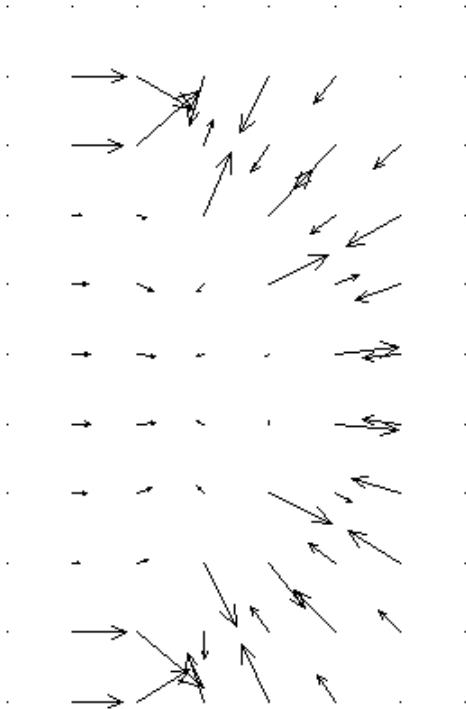

What we have:
gradient field of wrapped heights

Fig.: © DLR

Phase Unwrapping Problem Statement

interferometric phase: $\phi(i, k) = \underbrace{\phi_T(i, k)}_{\text{useful (e.g. topography induced) phase}} + \underbrace{\phi_N(i, k)}_{\text{phase noise}}$ “absolute” phase

useful (e.g. topography induced) phase phase noise

wrapped phase: $\psi(i, k) = W\{\phi(i, k)\}$ with $W\{\cdot\}$: wrapping operator
 and $-\pi < \psi \leq \pi$ [rad]
 or $-\frac{1}{2} < \psi \leq \frac{1}{2}$ [phase cycles]

phase unwrapping problem: Given $\psi(i, k)$ find an estimate $\hat{\phi}(i, k)$ or even $\hat{\phi}_T(i, k)$

many solutions possible \Rightarrow additional constraints required (smoothness, ...)

\Rightarrow find „most likely“ phase

Find the “Most Likely” Solution

this is much more likely ...

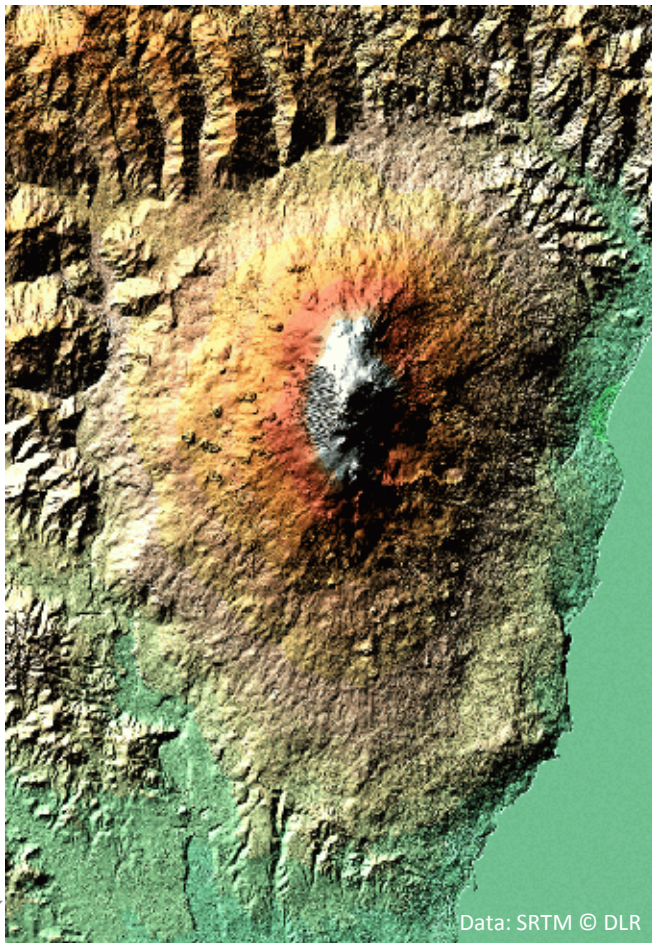

... than this



Wrapped Interferometric Phase

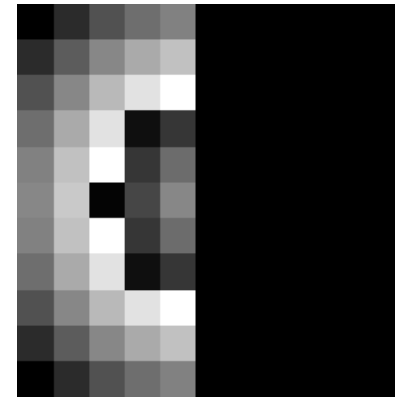
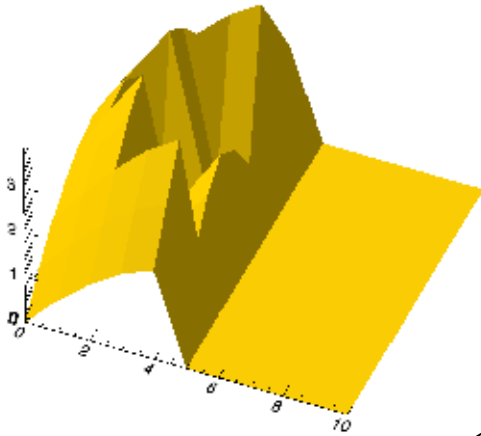

Wrapped height matrix

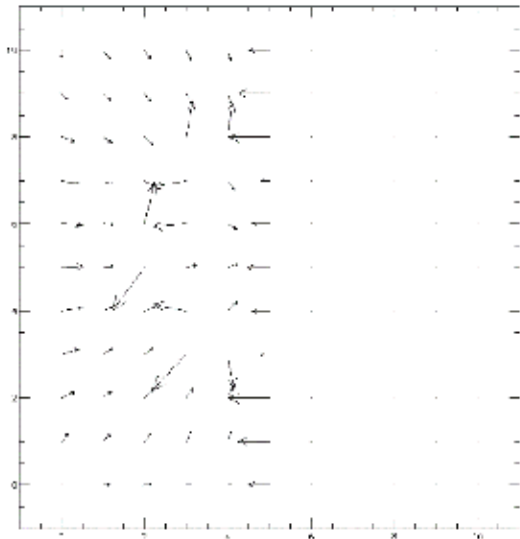

Gradient field of wrapped height matrix (=conservative)

Integration of gradient field of wrapped height matrix will give wrapped height matrix

→ this is **not** what we want

A Simple and Common Gradient Estimator

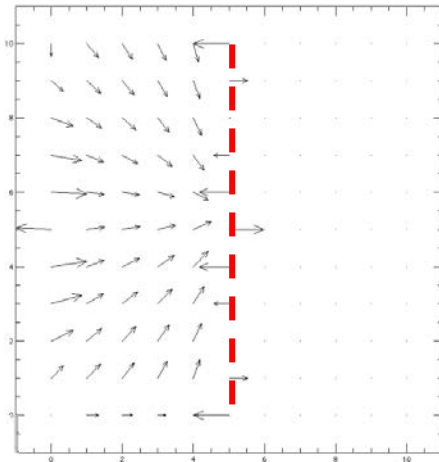
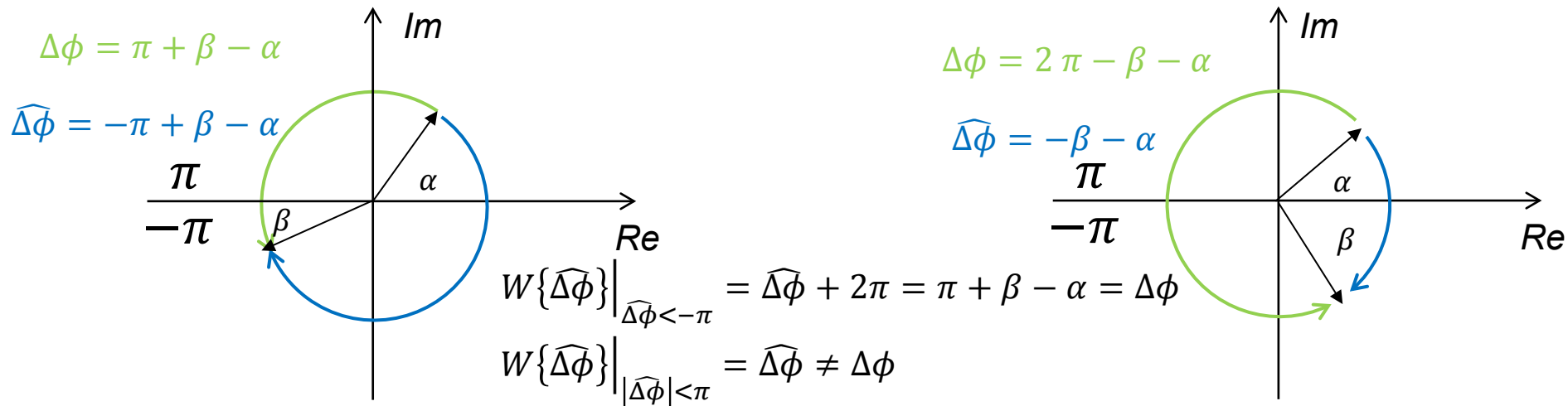

Wrapped gradient field (not conservative)

Integration of wrapped gradient field gives **almost** the unwrapped height matrix, but **strong gradients** ($> \pi$, $< -\pi$) are underestimated.

Where are those distortions?

→ Analysis of local “conservativeness”

Unwrapping of a 1-D Phase Ramp: High Coherence

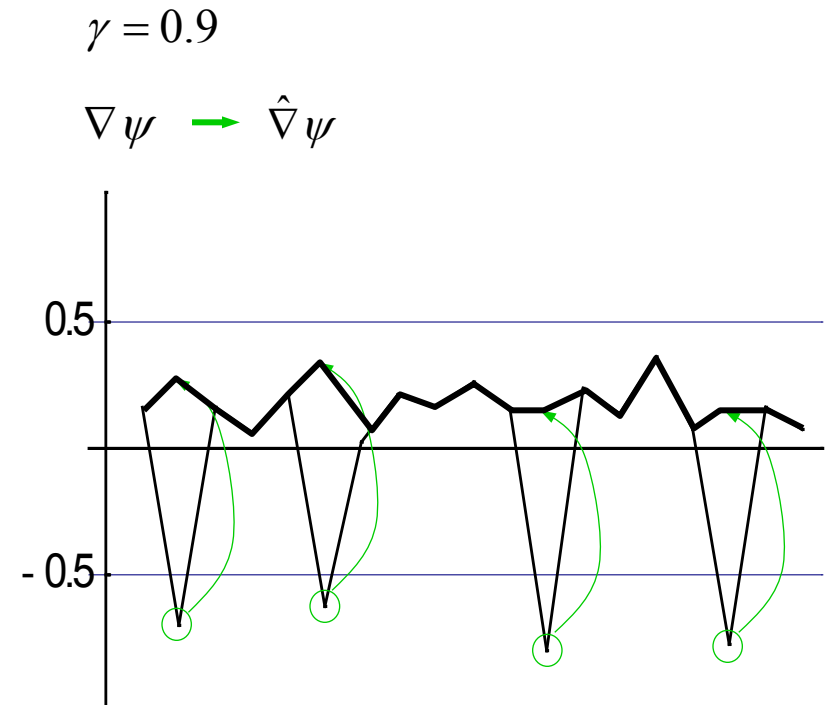
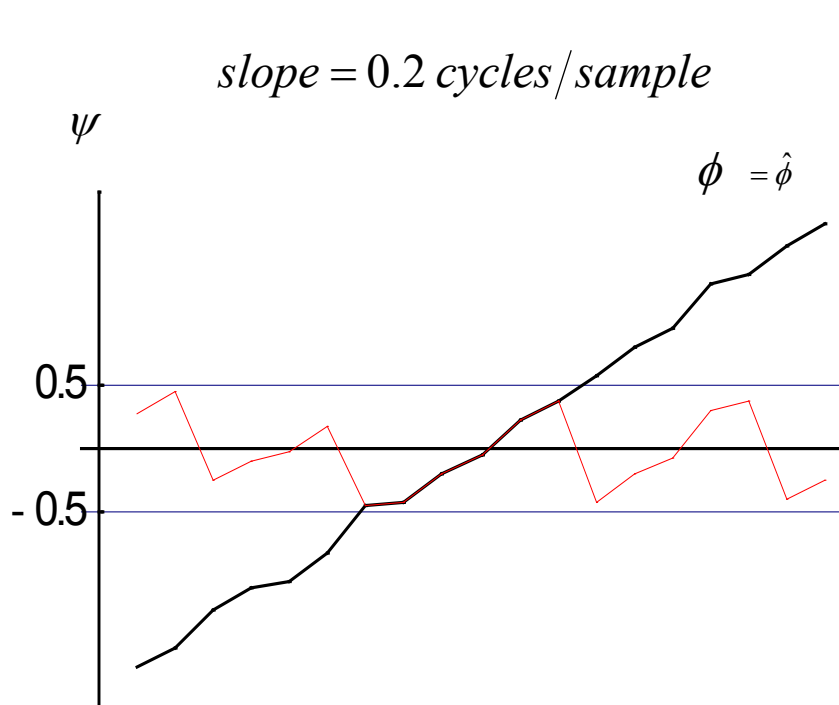

Integration of $\hat{\nabla} \psi$ gives the correct solution $\hat{\phi}$



Fig.: © DLR

Unwrapping of a 1-D Phase Ramp: Medium Coherence

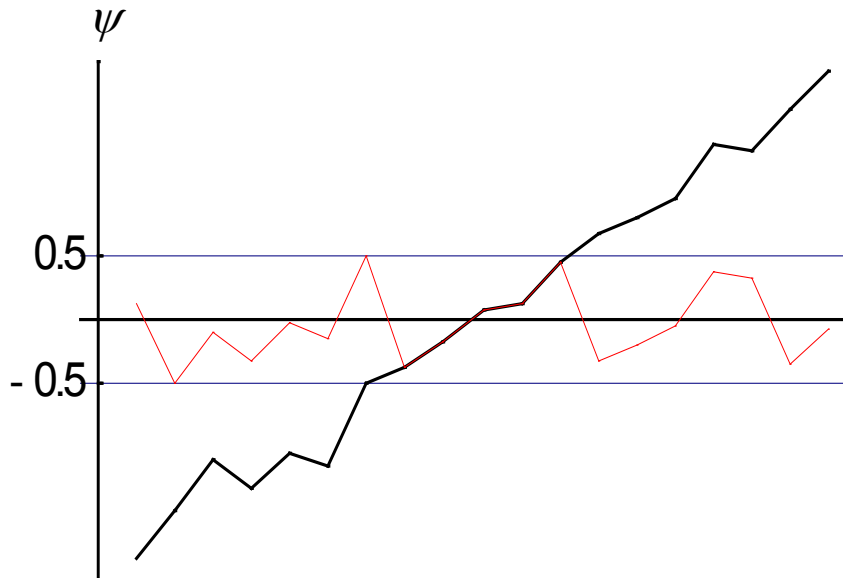

Integration of wrong $\hat{\nabla} \psi$ results in unwrapping error: 1 cycle lost

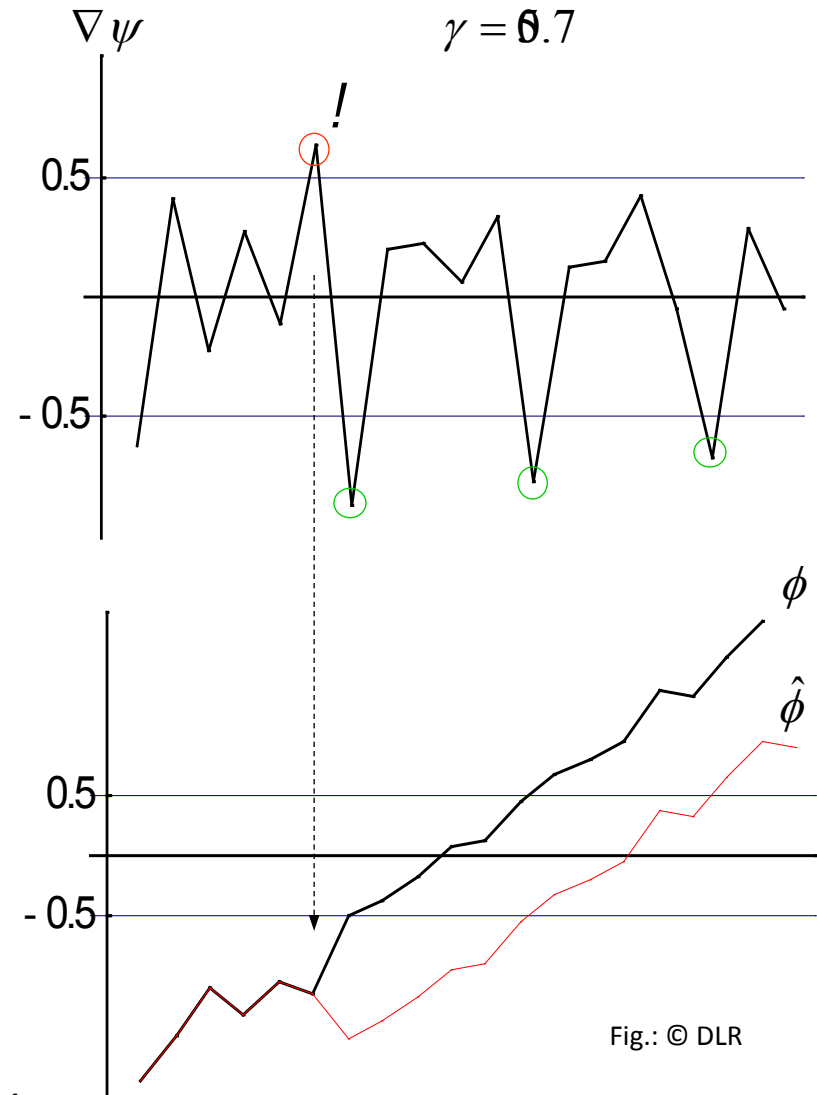

Fig.: © DLR

Derivatives of 2-D Functions on a Regular Discrete Grid: Gradient

2-D scalar
field:

$$F(i, k)$$

partial
derivatives:

$$\Delta_i F(i, k) = F(i+1, k) - F(i, k)$$

$$\Delta_k F(i, k) = F(i, k+1) - F(i, k)$$

gradient:

$$\nabla F(i, k) = \begin{pmatrix} \Delta_i F(i, k) \\ \Delta_k F(i, k) \end{pmatrix}$$

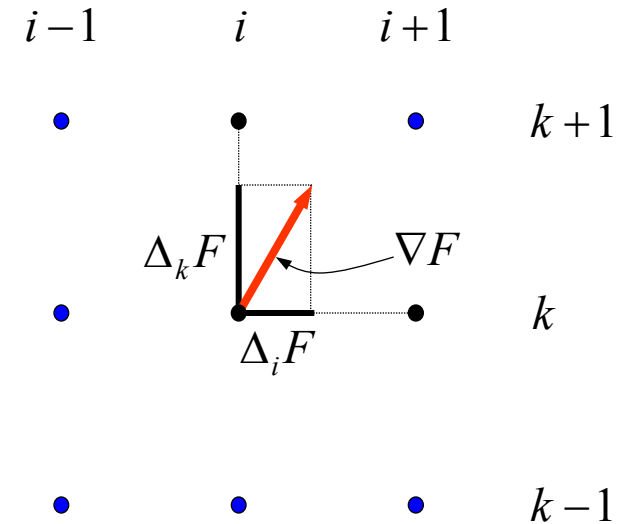

Fig. 16: © DLR

Derivatives of 2-D Functions on a Regular Discrete Grid: Curl

2-D vector field: $\vec{A}(i, k) = \begin{pmatrix} A_i(i, k) \\ A_k(i, k) \end{pmatrix}$

curl:

$$\begin{aligned} \nabla \times \vec{A}(i, k) &= \Delta_i A_k(i, k) - \Delta_k A_i(i, k) \\ &= A_k(i+1, k) - A_k(i, k) - A_i(i, k+1) + A_i(i, k) \\ &= \oint_{C_4} \vec{A}(i, k) \cdot d\vec{c} \end{aligned}$$

vector
product

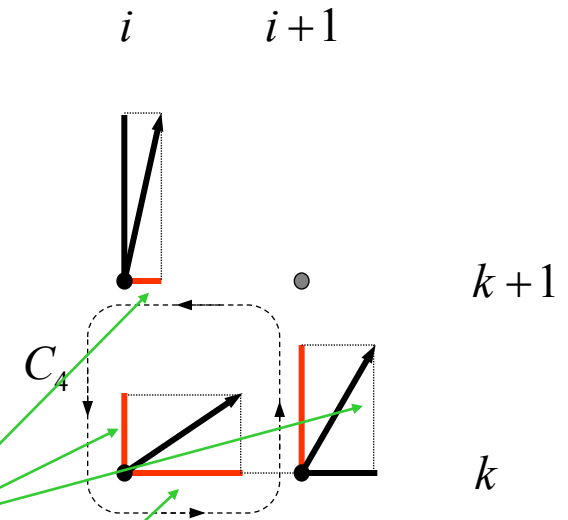

note: curl of a 2-D vector field is a scalar

Gradient-Based Phase Unwrapping

1. Find an estimate of $\nabla\phi(i,k)$ based on $\psi(i,k)$: $\hat{\nabla}\psi(i,k)$

2. Integrate $\hat{\nabla}\psi(i,k)$ to get $\hat{\phi}(i,k)$

simple gradient estimate: $\hat{\nabla}\psi(i,k) = \begin{pmatrix} W\{\Delta_i\psi(i,k)\} \\ W\{\Delta_k\psi(i,k)\} \end{pmatrix}$ „wrapped gradient of wrapped phases“

If $|\Delta_i\psi(i,k)| < \pi$ and $|\Delta_k\psi(i,k)| < \pi \Rightarrow \hat{\nabla}\psi(i,k) = \nabla\phi(i,k)$

in reality: $\hat{\nabla}\psi(i,k) \neq \nabla\phi(i,k) \Rightarrow \nabla \times \hat{\nabla}\psi(i,k) \neq 0$

i.e. $\hat{\nabla}\psi(i,k)$ is in general not conservative and the integration result depends on the path

(note: $\nabla \times \nabla\phi(i,k) = 0$ per definition)

Residues

For a conservative field any closed integration path must give zero integral value.

⇒ Test field $\hat{\nabla} \psi(i, k)$ for conservativeness by computing the smallest closed integrals C_4 for every quadrupel of pixels

⇒ Residue field

$$\text{res}(i, k) = \oint_{C_4} \hat{\nabla} \psi(i, k) \cdot d\vec{c} = \nabla \times \hat{\nabla} \psi(i, k) = \begin{cases} 0 & \text{no residue} \\ +2\pi & \text{or: } 1 \text{ (cycle)} & \text{positive residue} \\ -2\pi & \text{or: } -1 \text{ (cycle)} & \text{negative residue} \end{cases}$$

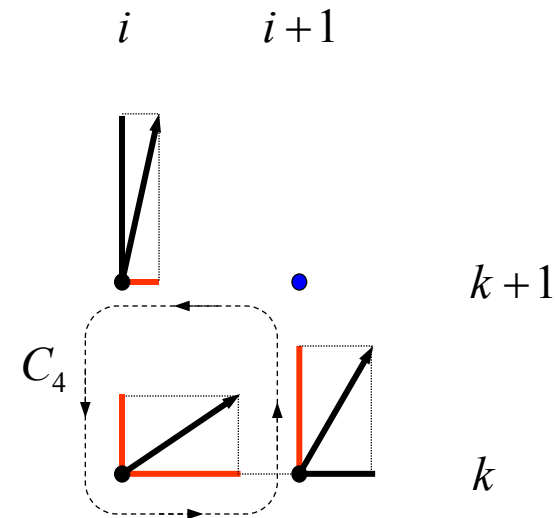

Residues in nature?

M.C. Escher Waterfall (1961)

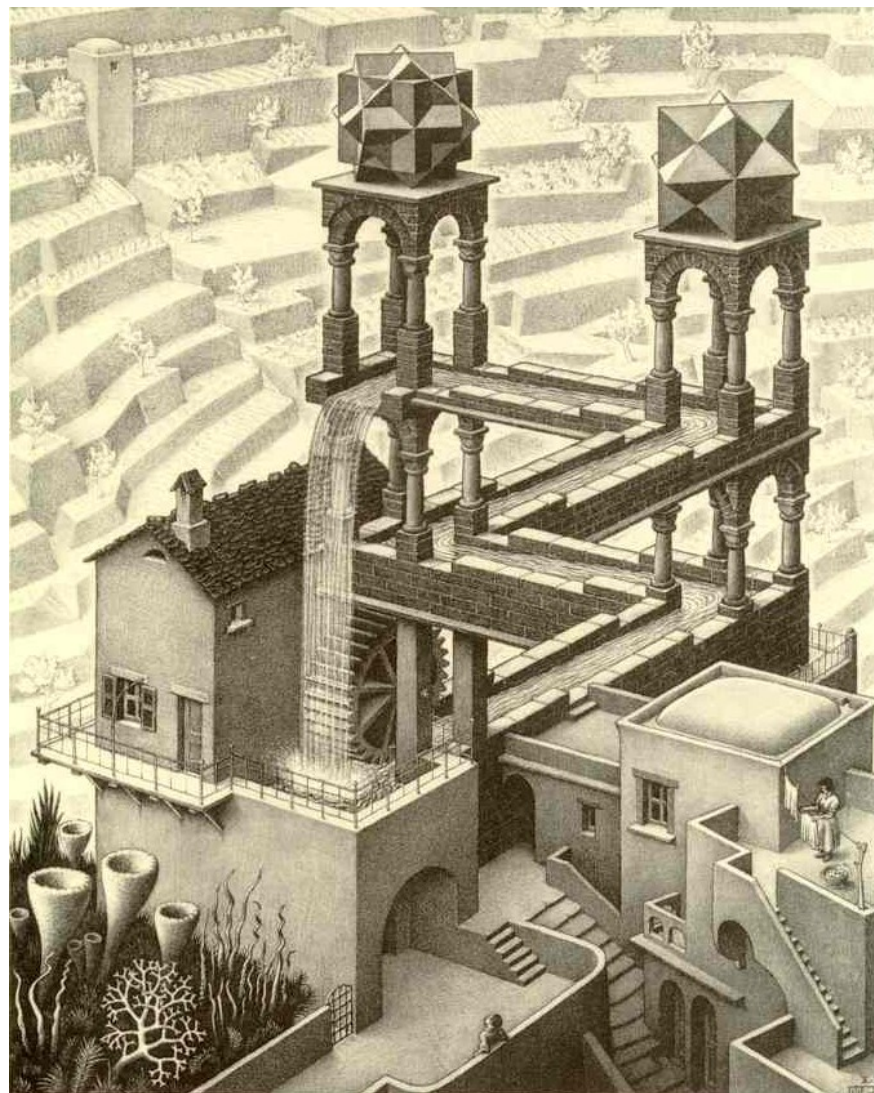

Typical Residue Distribution

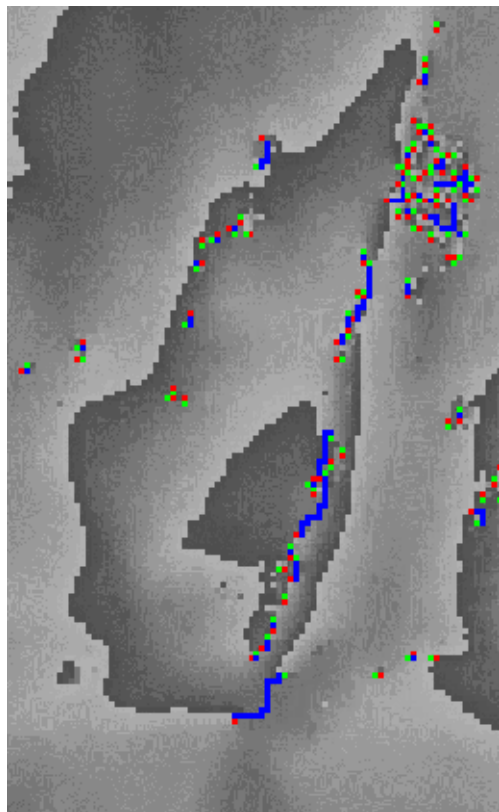

red: positive residue
green: negative residue
blue: branch cut

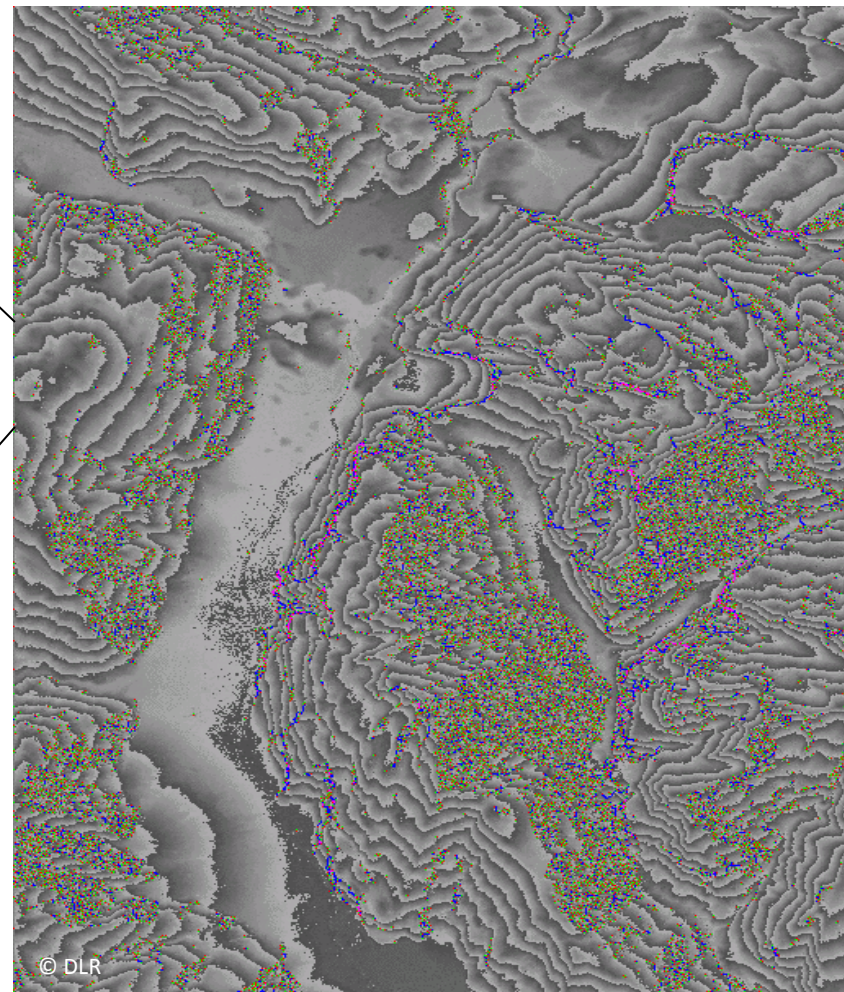

© DLR
Data: SRTM X-SAR

Structure

- First milestones of SAR interferometry
- Interferogram formation
- Techniques
- InSAR data processing sequence
- Phase unwrapping
- InSAR satellites and examples

SAR Satellites

Satellite:

- 500-900 km altitude
- **11-45 days repeat orbit**

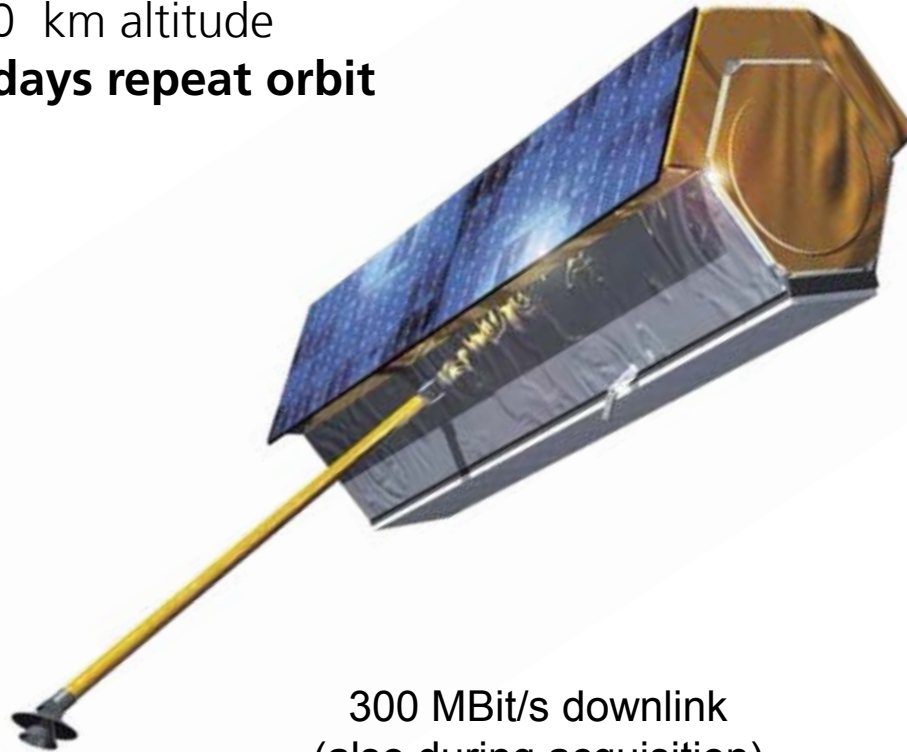

300 MBit/s downlink
(also during acquisition)

Active array SAR antenna

- 384 sub-arrays
- right looking / left looking
- **elevation beams**
 - ScanSAR
- **azimuth beams**
 - Spotlight
- transmit and receive in H or V
 - Dual polarization
- Experimental „dual receive antenna“ +redundant receiver
 - GMTI

SAR Satellites Orbits

Ascending

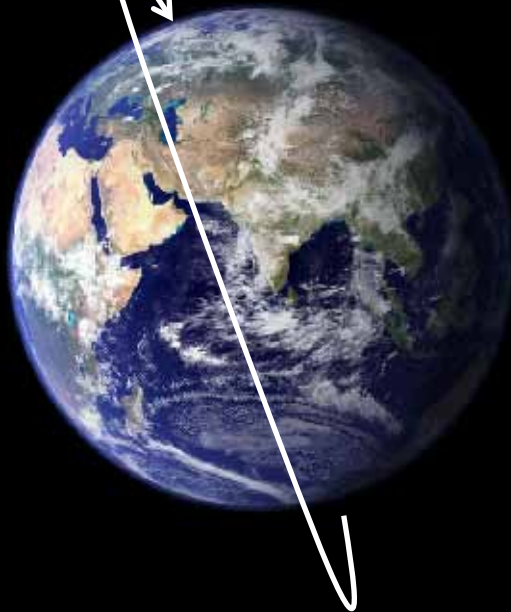

Descending

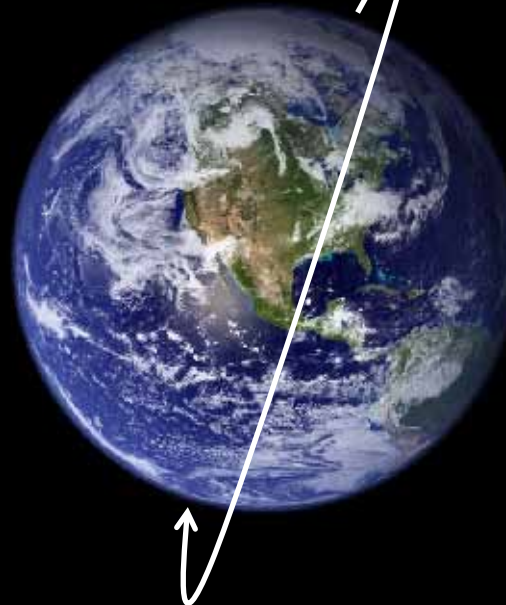

Credit: NASA Goddard Space Flight Center Image by Reto Stöckli : <http://visibleearth.nasa.gov>

- Height 500 – 900 Km
- Velocity ~7.5 Km/s
- Orbit Period 90-100 min.
- Scene Dimensions 10-250 Km
- Sun Synchronous Orbit

Satellites for SAR Interferometry: ERS-1



1990

1995

2000

2005

2010

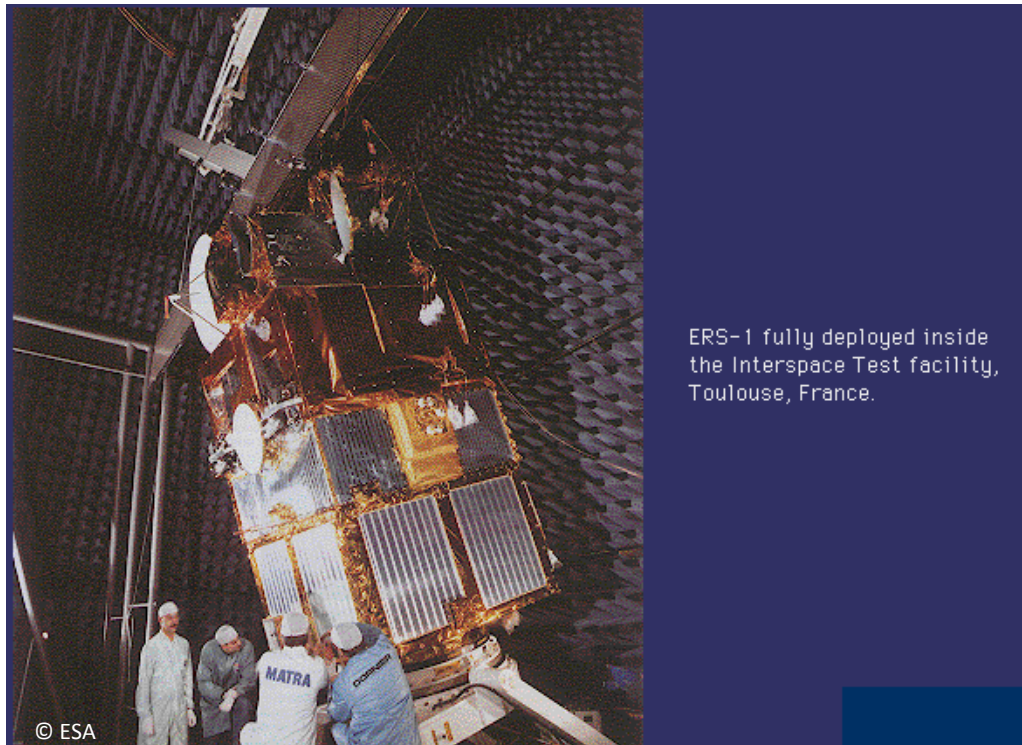

ERS-1 fully deployed inside the Interspace Test facility, Toulouse, France.

© ESA

<http://earth.esa.int/ers/satconc/satconc.html>

- Operated by ESA
- Launched 1991 (†2000)
- C-Band (5.6 cm)
- 15.5 MHz bandwidth
- 35 day repeat polar orbit,
 - 3 day repeat ice phase
- Highly successful mission
- Initiated cross track and along track SAR interferometry

ERS-1 Highlight

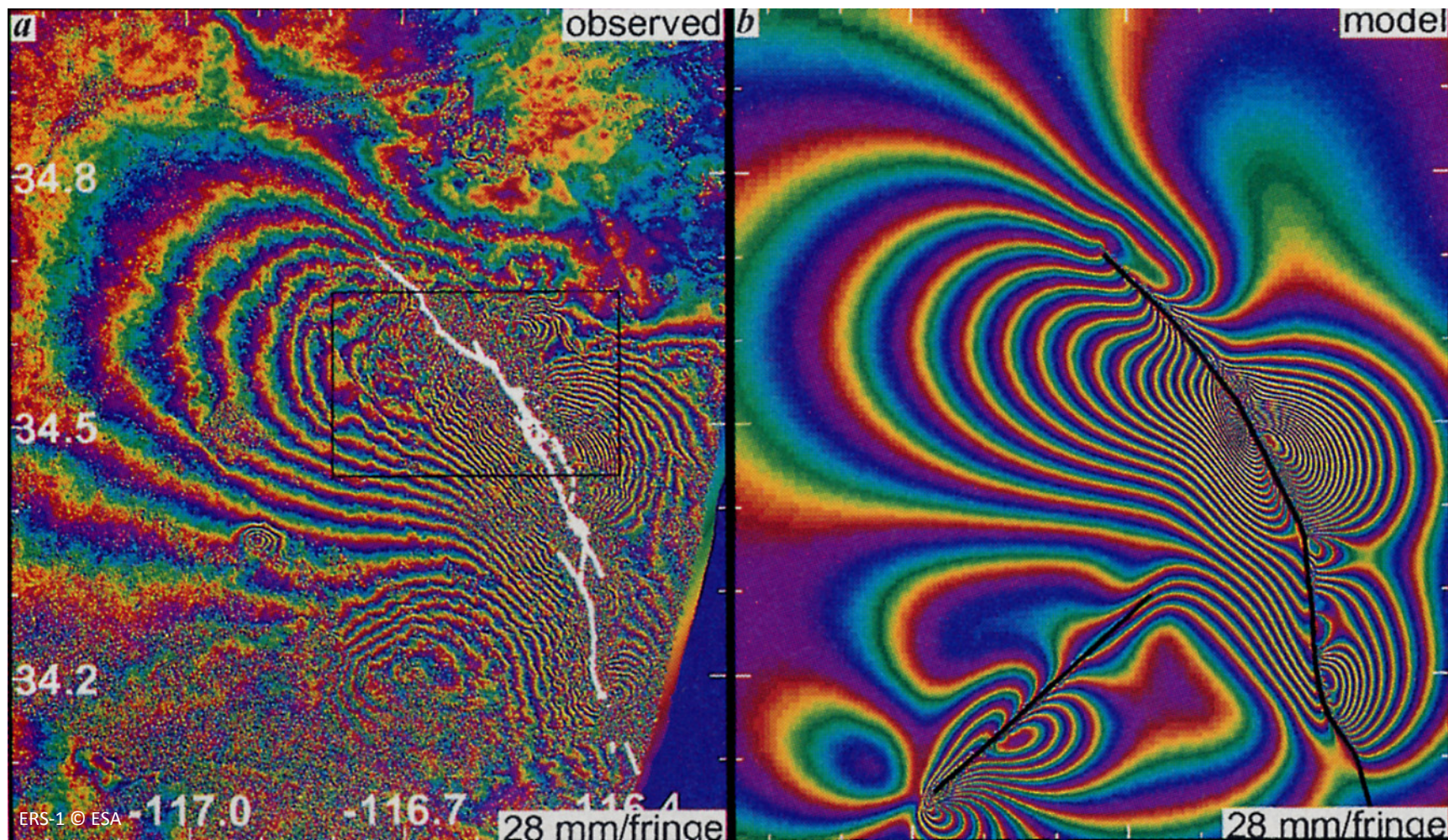
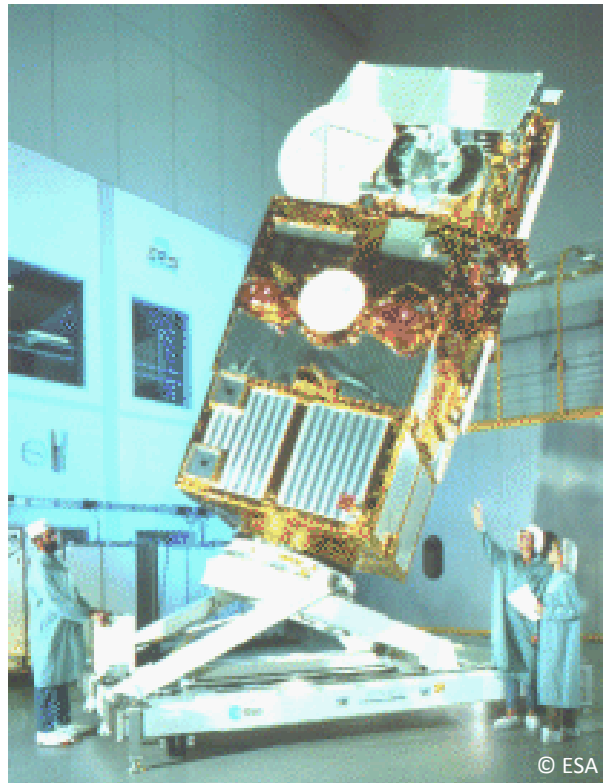
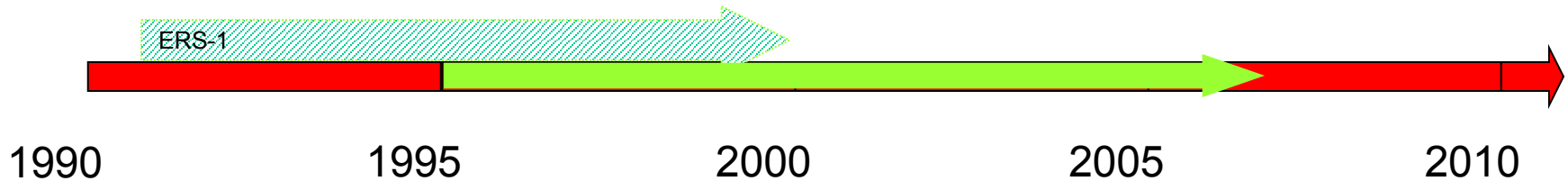

Fig.: The displacement field of the Landers earthquake mapped by radar interferometry (Massonnet et al., 1993)

Satellites for SAR Interferometry: ERS-2



http://earth.esa.int/rootcollection/e eo/_foto21b.gif

- Operated by ESA
- Launched 1995
- SAR instrument and orbit identical to ERS-1
 - 1 day time delay
- ERS-1/2 tandem operation 1995-1998
 - controlled baseline
- 1 day time lag → low decorrelation → DEM generation

ERS-1/2 Tandem Mission Result: DEM of Europe processed at DLR

- Acquisition time:
1995-2000
- Size of area:
610.000 km²
- Projection:
UTM zone 32
ellipsoid & datum: WGS84
- Pixel size:
25 m x 25 m
- Height error (1σ):
flatlands 4-8 m
moderate relief 8-30 m
alpine relief >>30 m

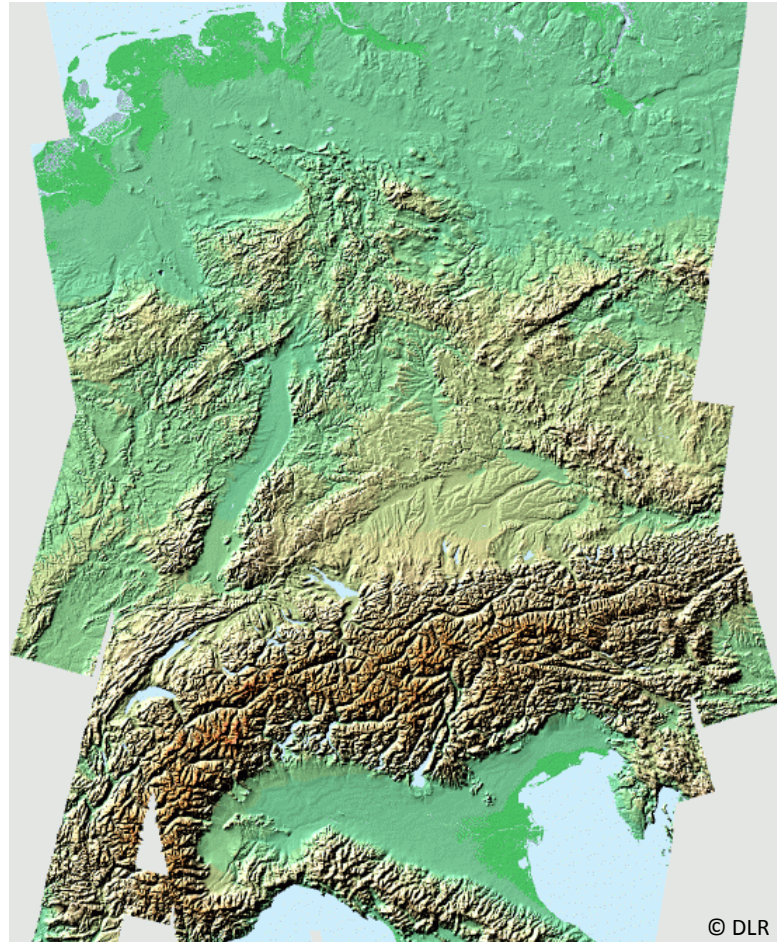

Persistent Scatterer Interferometry with ERS-1/ERS-2

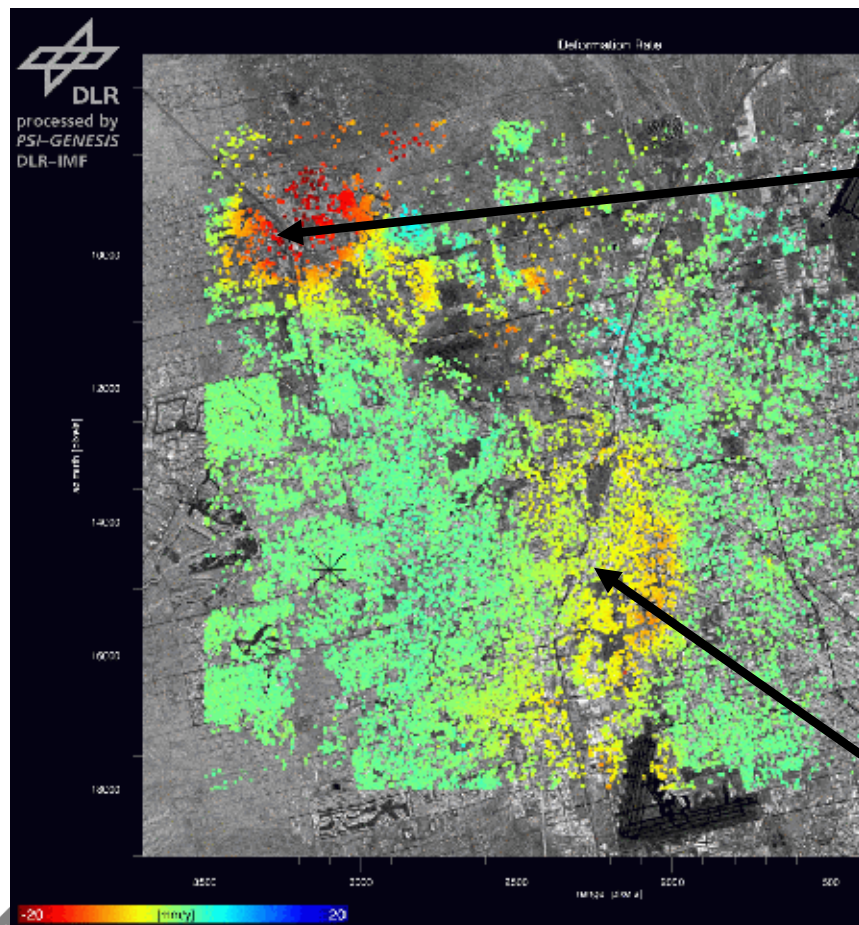

Area: Las Vegas

subsidence of point 81491: -18.5 ± 0.1 mm/a

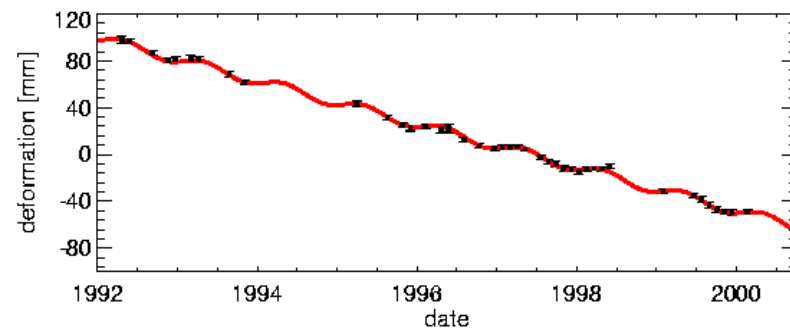

subsidence of point 167088: -4.1 ± 0.2 mm/a

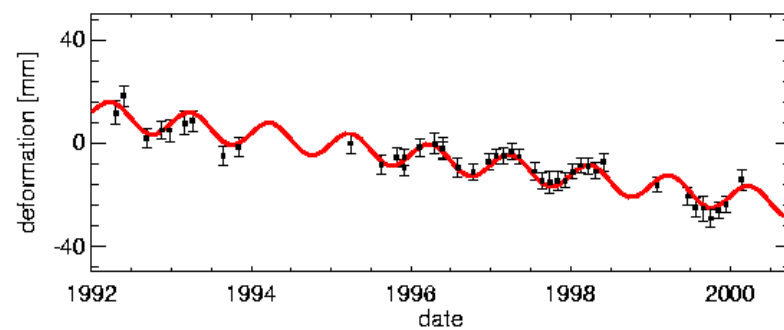

Satellites for Interferometry: ENVISAT/ASAR

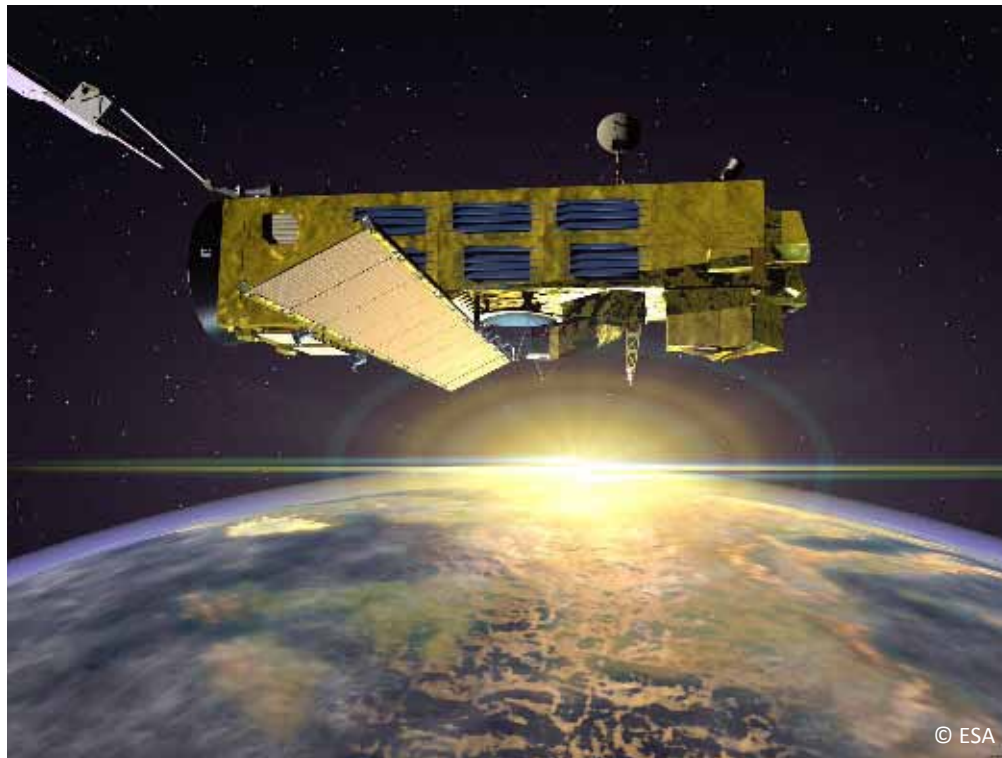
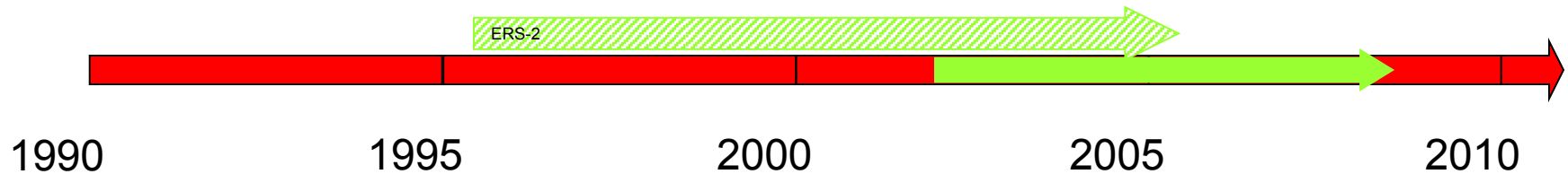

© http://www.esa.int/export/esaSA/ESAJZA8VTTC_earth_1.html

- ESA, Launch 2002
- Orbit like ERS-1/2
- More imaging modes
 - **ScanSAR (!)**
 - Polarimetric
- C-Band, shifted w.r.t. ERS-1/2 by +31 MHz
- **Not directly InSAR compatible with ERS**
- **Out of InSAR orbit since Oct. 2010**

First ERS-2 / ENVISAT ASAR Cross Interferogram

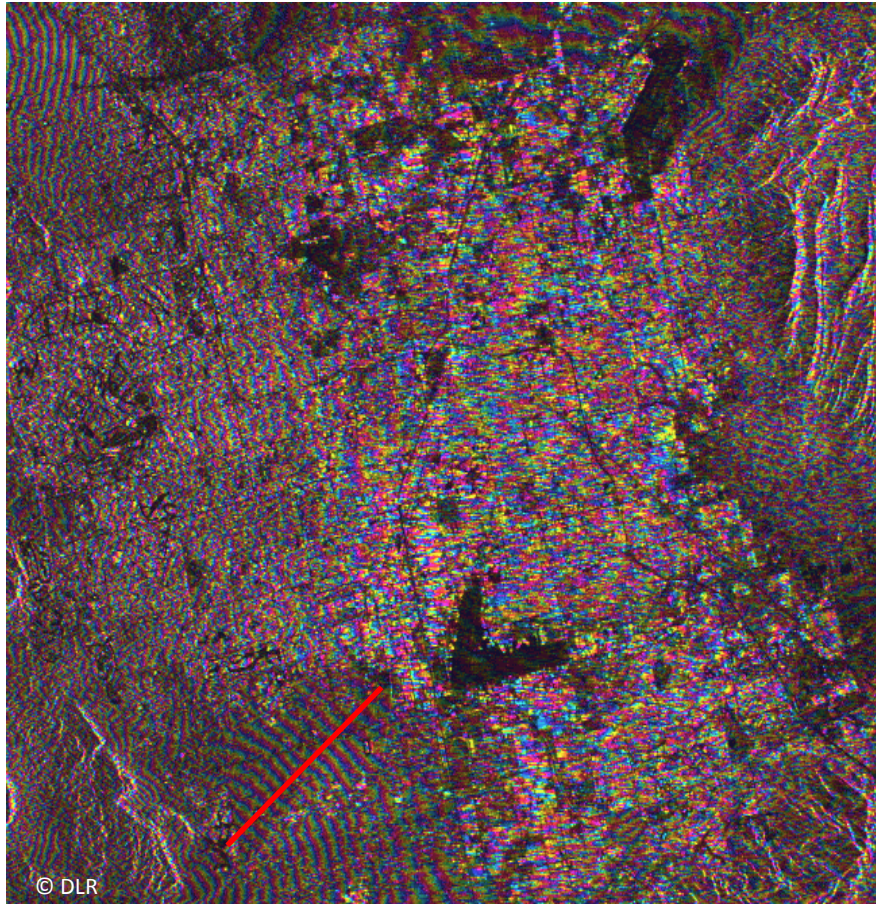

Las Vegas, processed by N. Adam / DLR

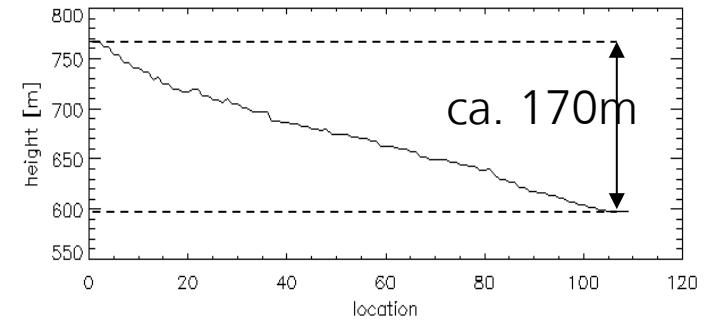

ca. 20 fringes $\Rightarrow 20 \times 8.43 = 168 \text{ m}$

Fig.: © DLR

ENVISAT Wide Swath Mode / Wide Swath Mode

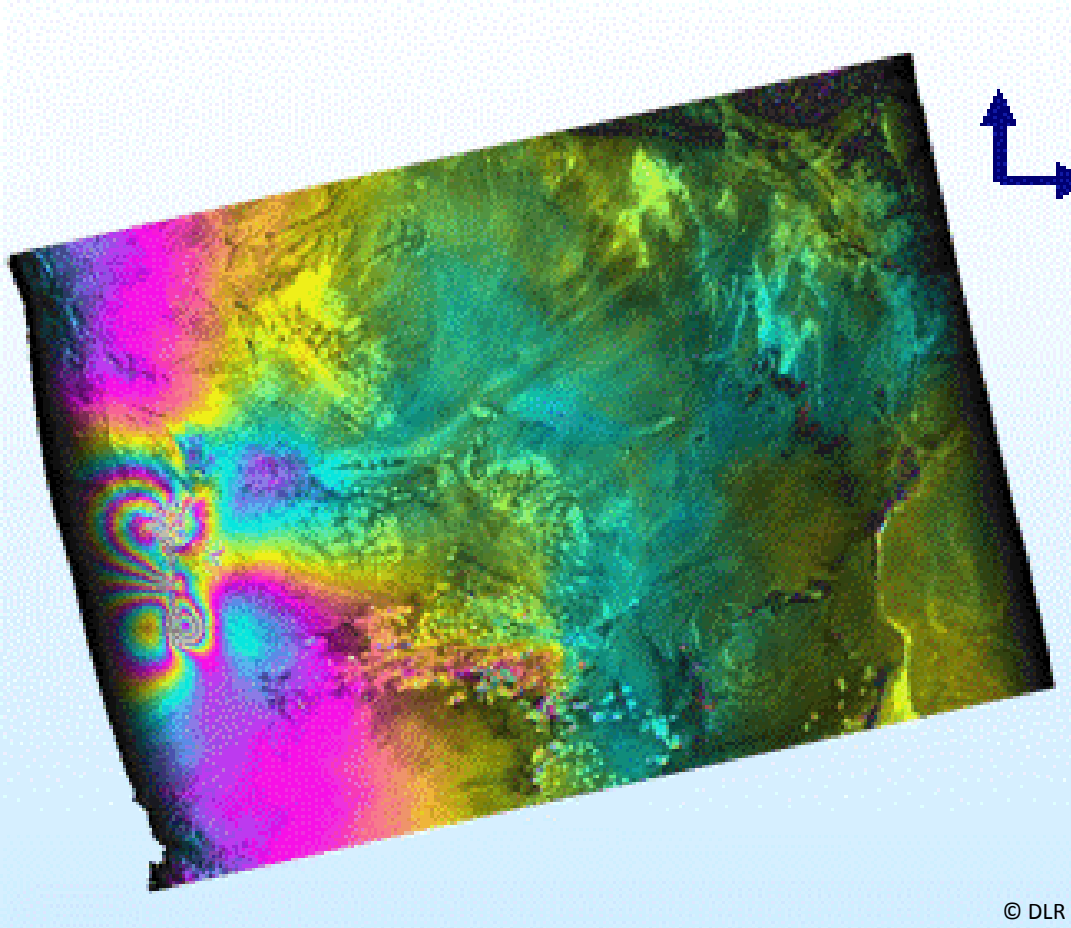

Wide swath (405km)
interferogram of Bam
earthquake Dec 2003

5 subswaths
60-100km subswath width
405km swath width
150m ground resolution

Small et al., 2005

Satellites for Interferometry: RADARSAT-1

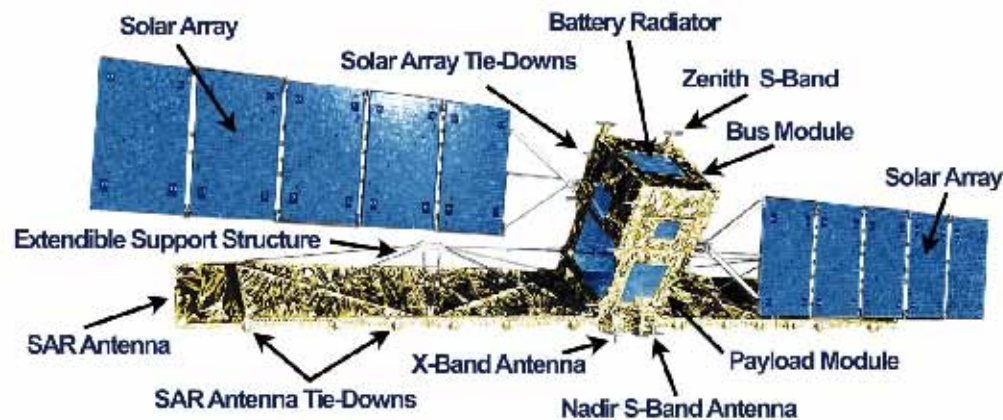
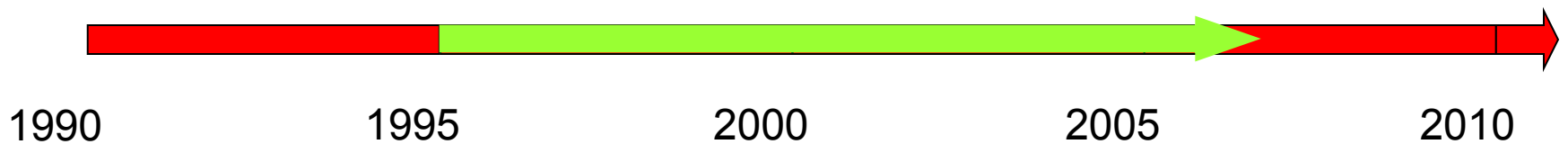

© Canadian Space Agency

- Canada, launched 1995
- C-Band
 - Incompatible with ERS, ASAR
- Many modes
 - ScanSAR
 - Higher resolution (30 MHz)
- Interferometry more difficult due to
 - Weak orbit control
 - Lower orbit precision

Satellites for Interferometry: JERS-1, ALOS / PALSAR

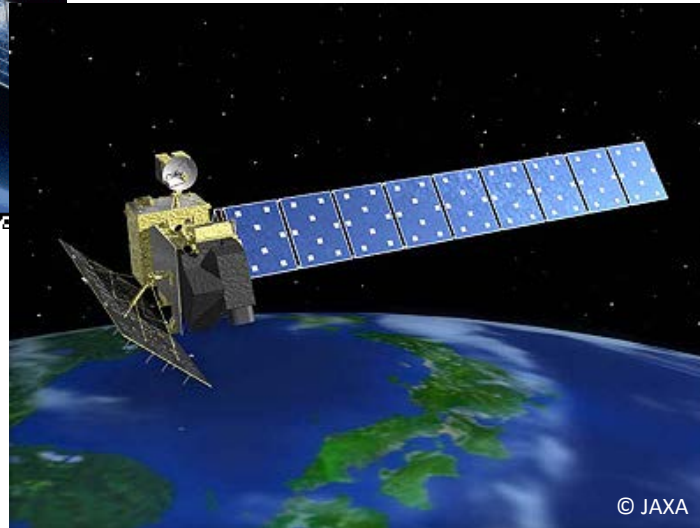
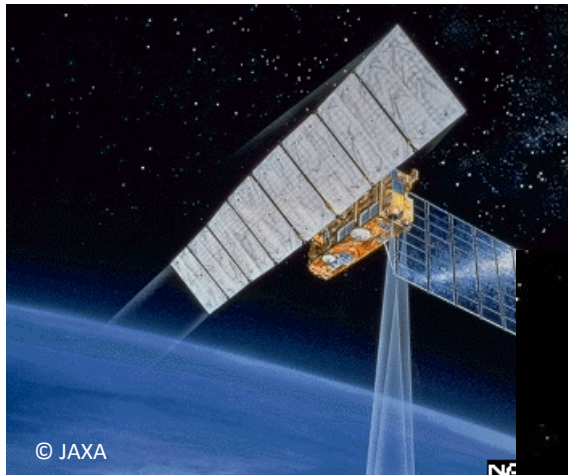
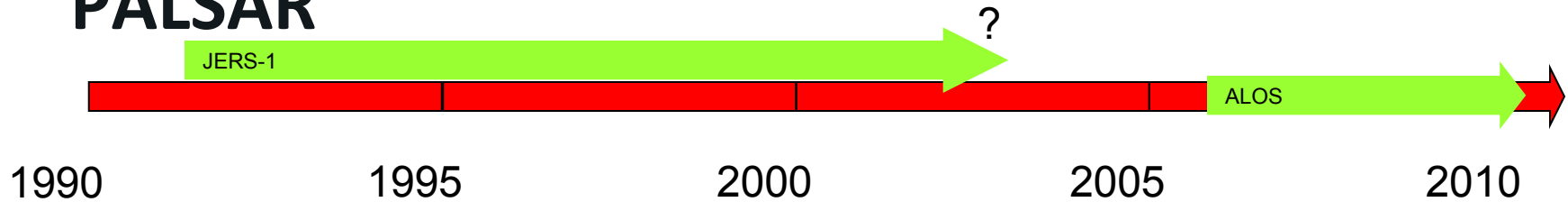

- JERS-1
 - Japan, 1992
 - L-Band
 - Initially little support for interferometry
 - Increasingly being used with good coherence
- ALOS/PALSAR
 - **Launched 2006**
 - Polarimetry
 - DInSAR-Mission
 - Long term coherence
 - **Failed 2011**
 - ALOS-2 in orbit

ALOS Interferogram

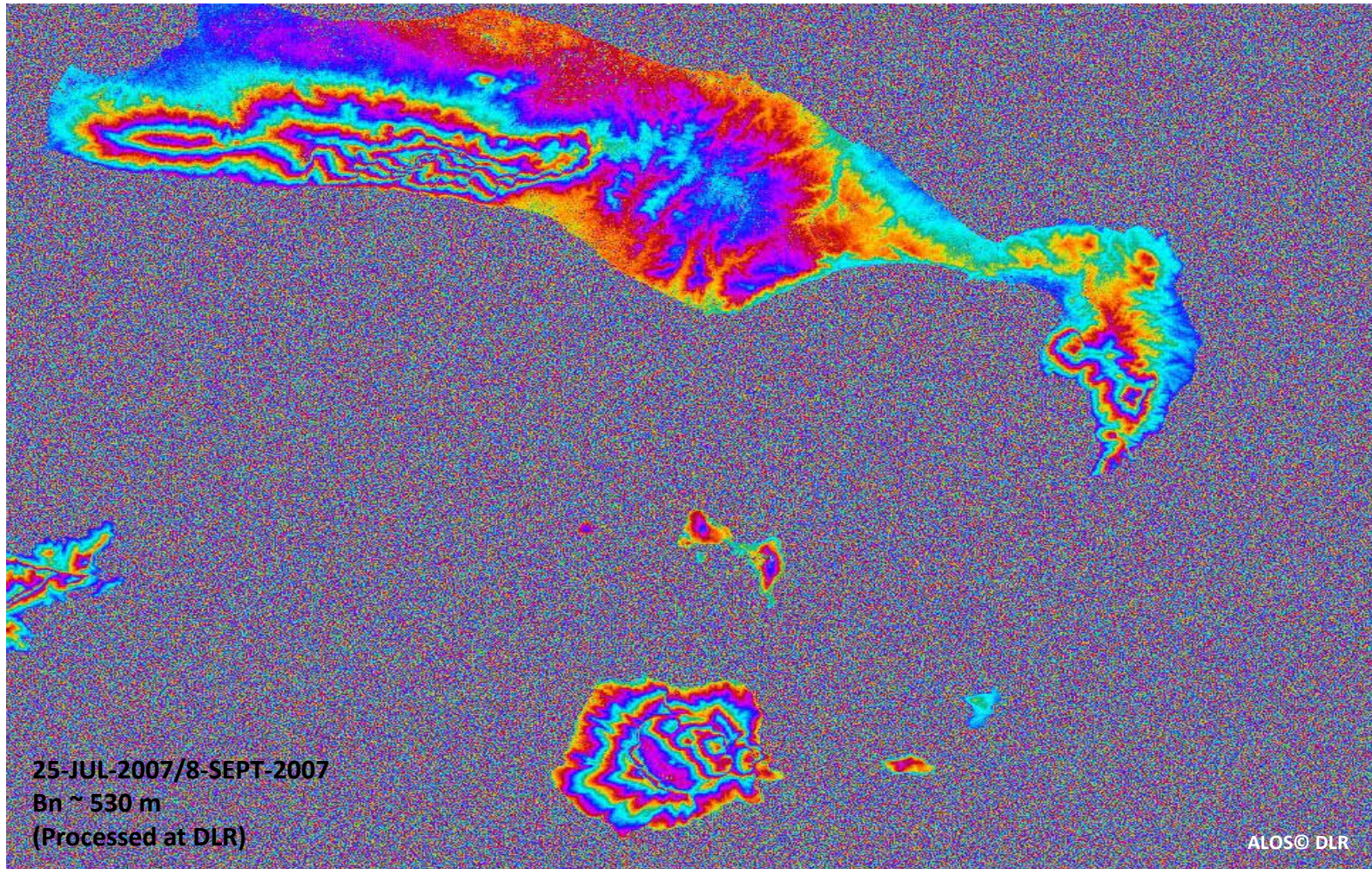

Satellites for Interferometry: TerraSAR-X

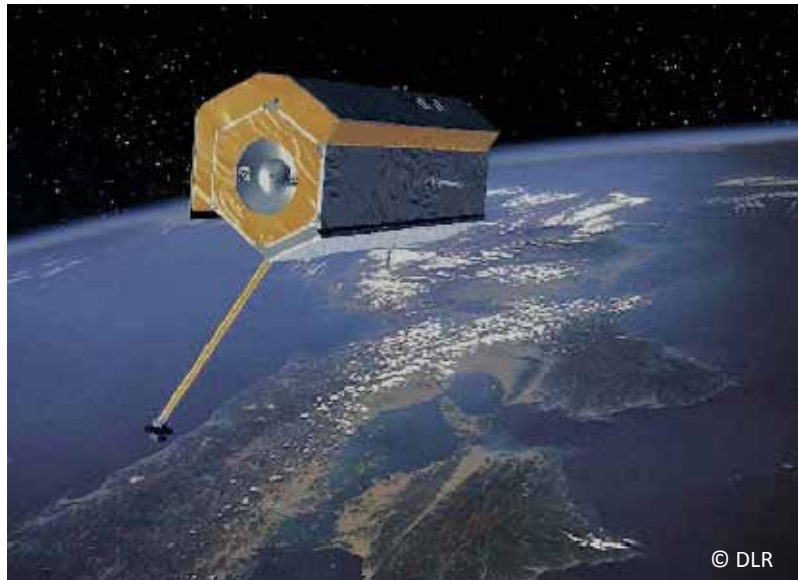
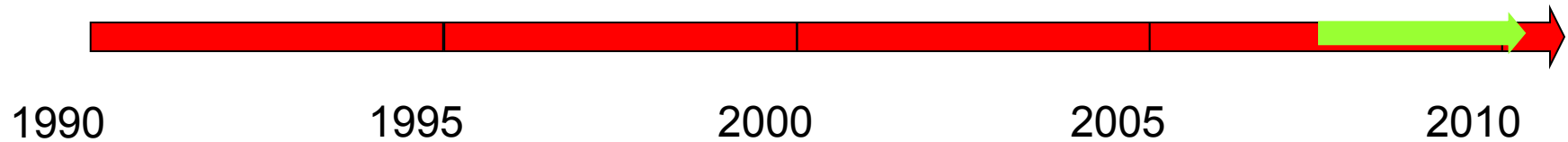

- Germany
 - TSX1 launched 2007
 - TDX1 launched 2010
- X-Band
- Many modes
Spotlight, ATI
- Polarimetric
- 11 day repeat
- High resolution (150 MHz, 1 m class)
 - Large baselines
- Fast decorrelation on vegetation

TerraSAR-X: Tokyo @ 300 MHz High Resolution Spotlight
 $B=158$ m, 43.8 m/fringe

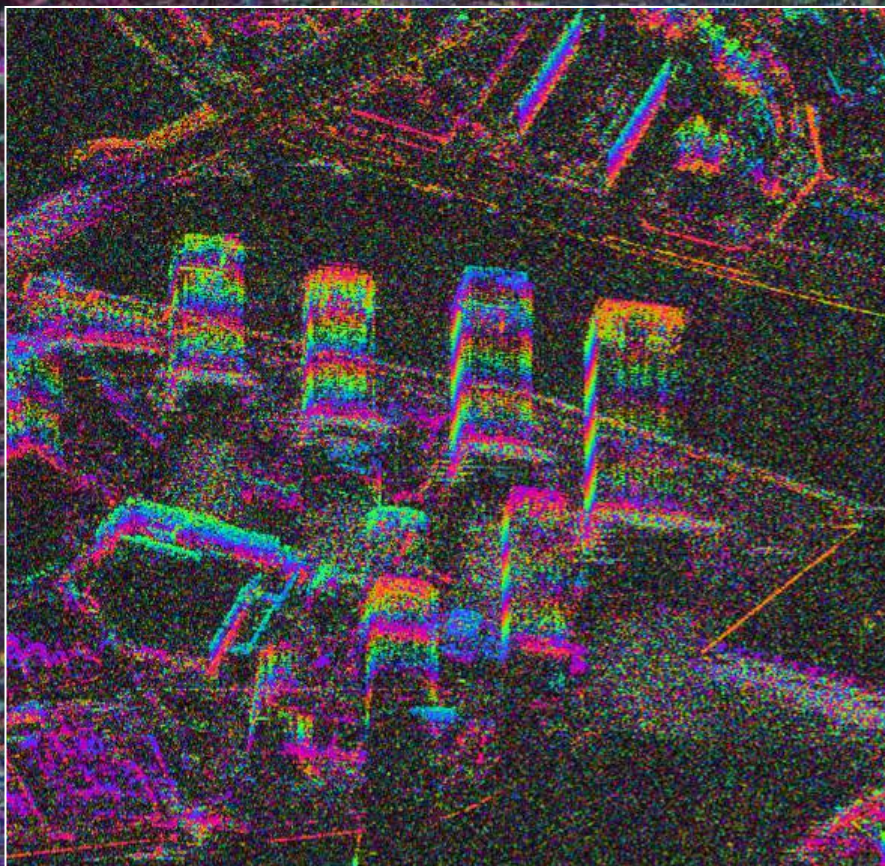

TerraSAR-X © DLR

Single Pass Missions

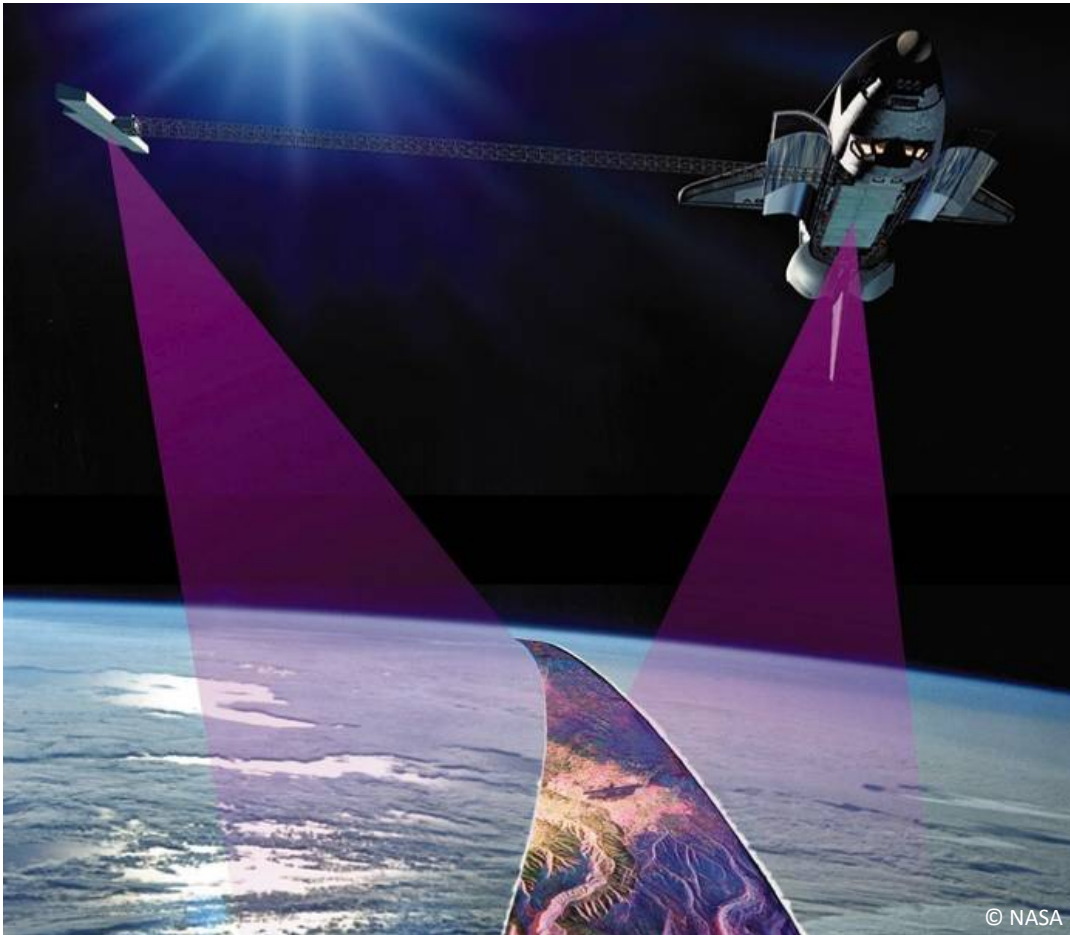

SRTM

- USA/Germany/Italy, 11 days in 2000
- X+C-Band,
- Dedicated single pass interferometer
- Global DEM between $\pm 60^\circ$

SRTM Imaging Geometry

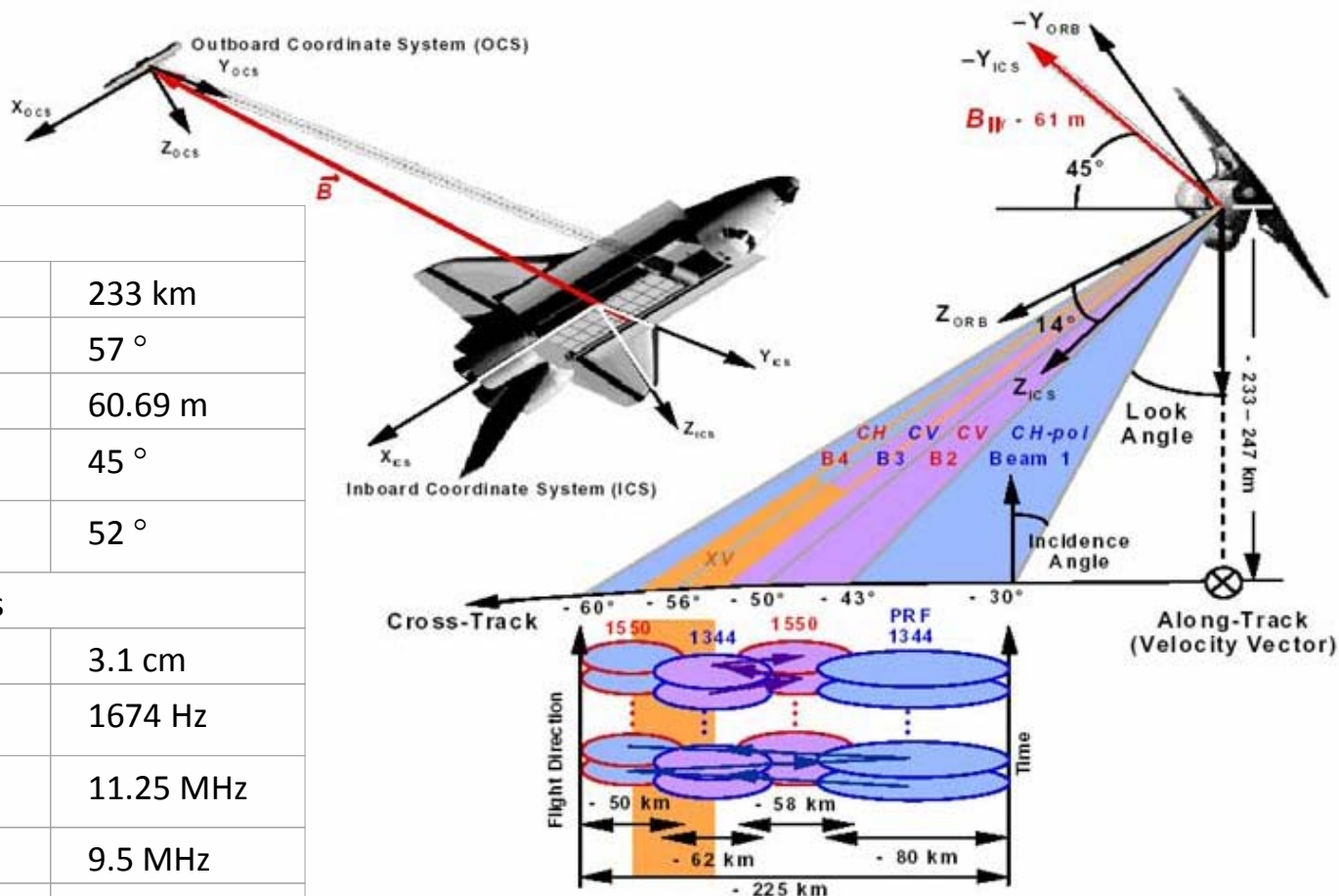

Geometry parameters

Orbit height 233 km

Orbit inclination 57°

Nominal baseline 60.69 m

Nominal baseline tilt angle 45°

Look angle at swath center 52°

X-SAR instrument parameters

Wavelength 3.1 cm

Pulse repetition frequency 1674 Hz

Range sampling frequency 11.25 MHz

Chirp bandwidth 9.5 MHz

Proc. azimuth bandwidth 1180 Hz

Fig.: © NASA

Nanga Parbat (8125m) as seen by SRTM-X

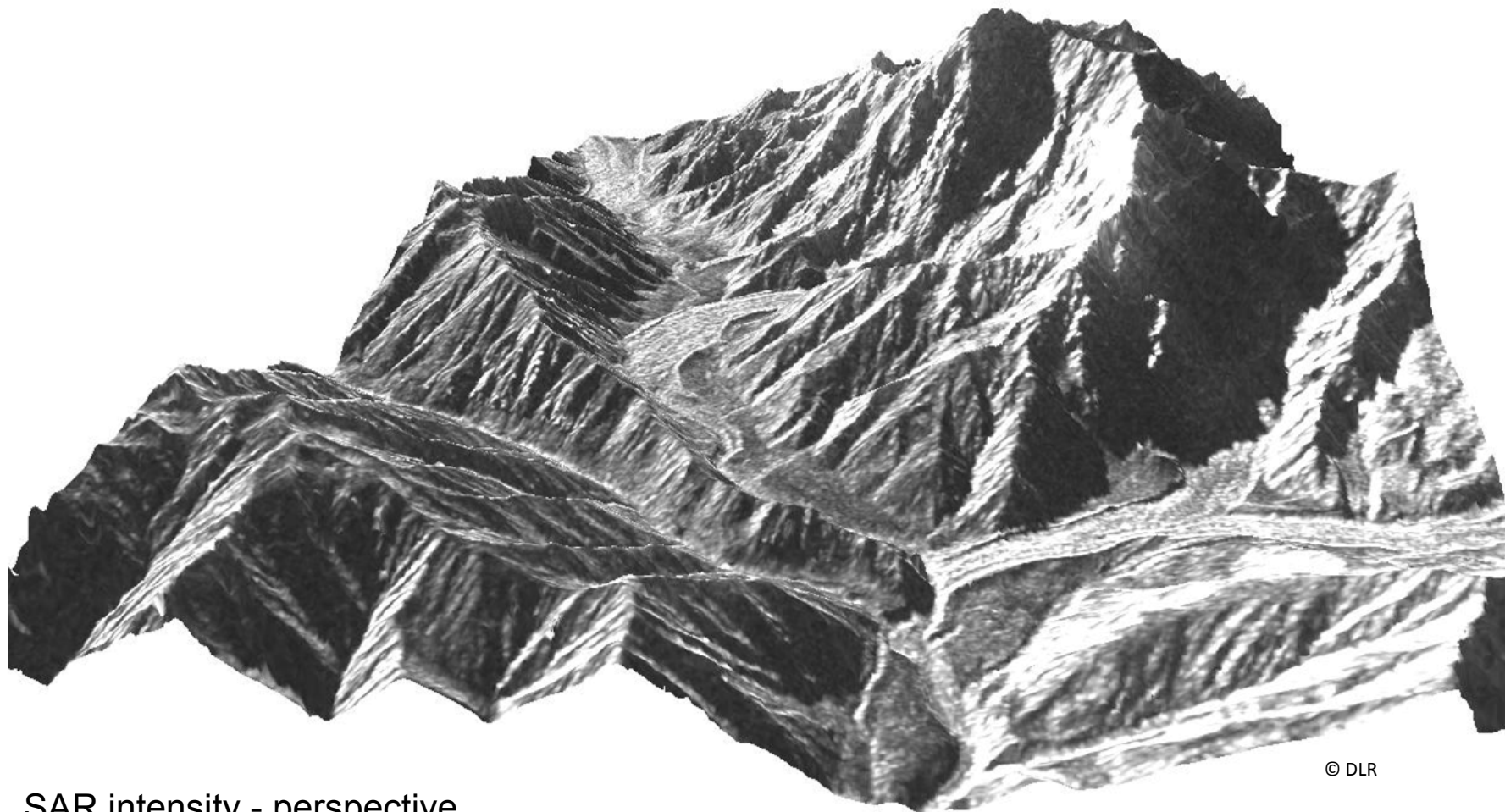

© DLR

SAR intensity - perspective

SRTM/X-SAR Image

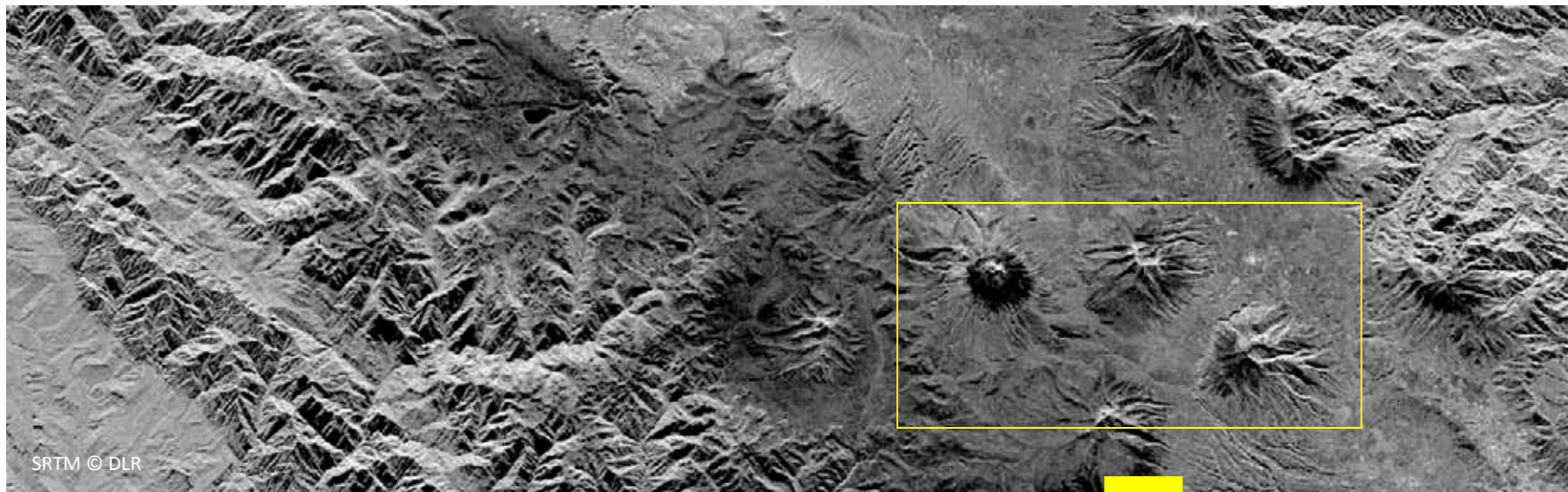

Volcano Cotopaxi
Ecuador

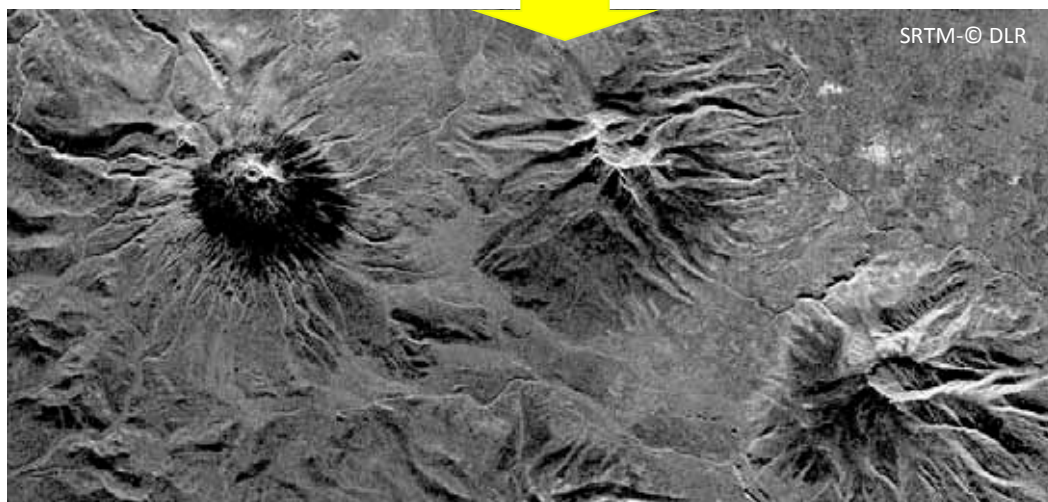

SRTM/X-SAR Interferometric Phase

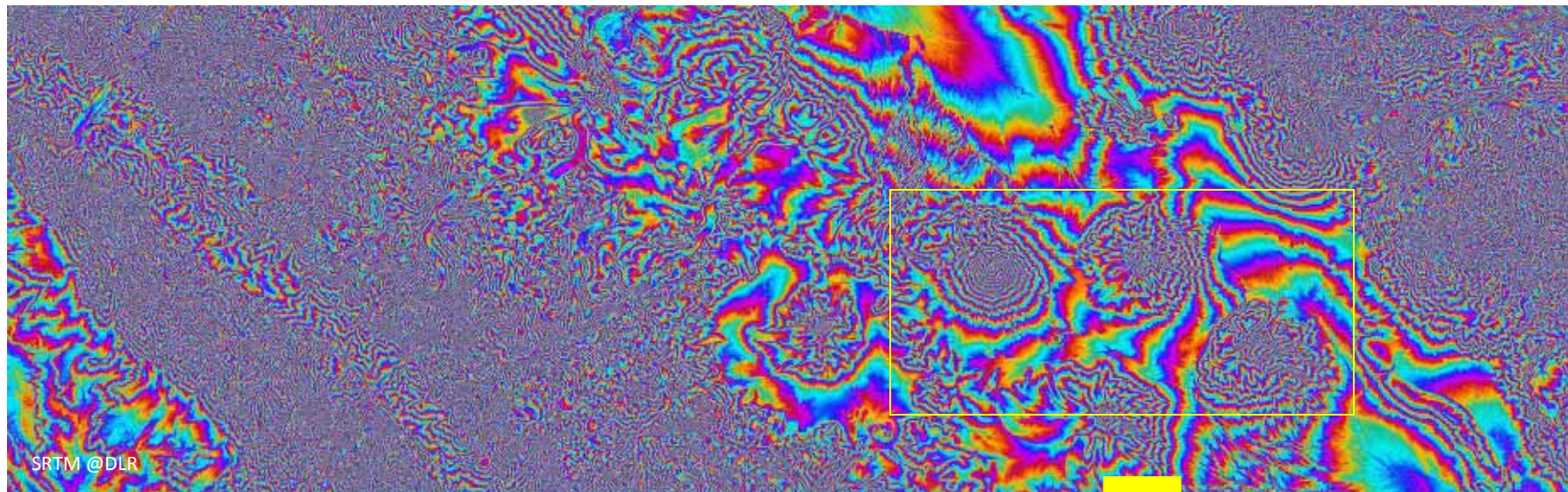

Volcano Cotopaxi
Ecuador

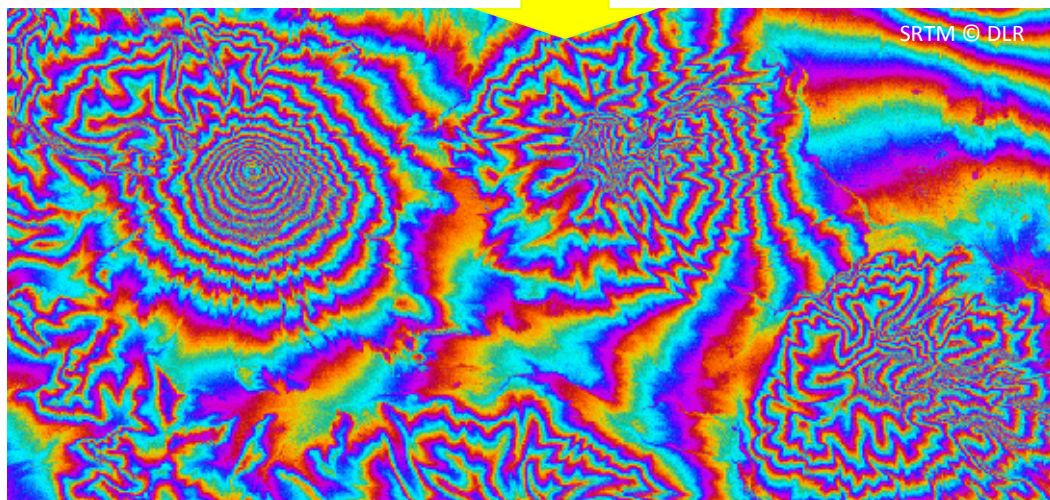

SRTM/X-SAR Digital Elevation Model

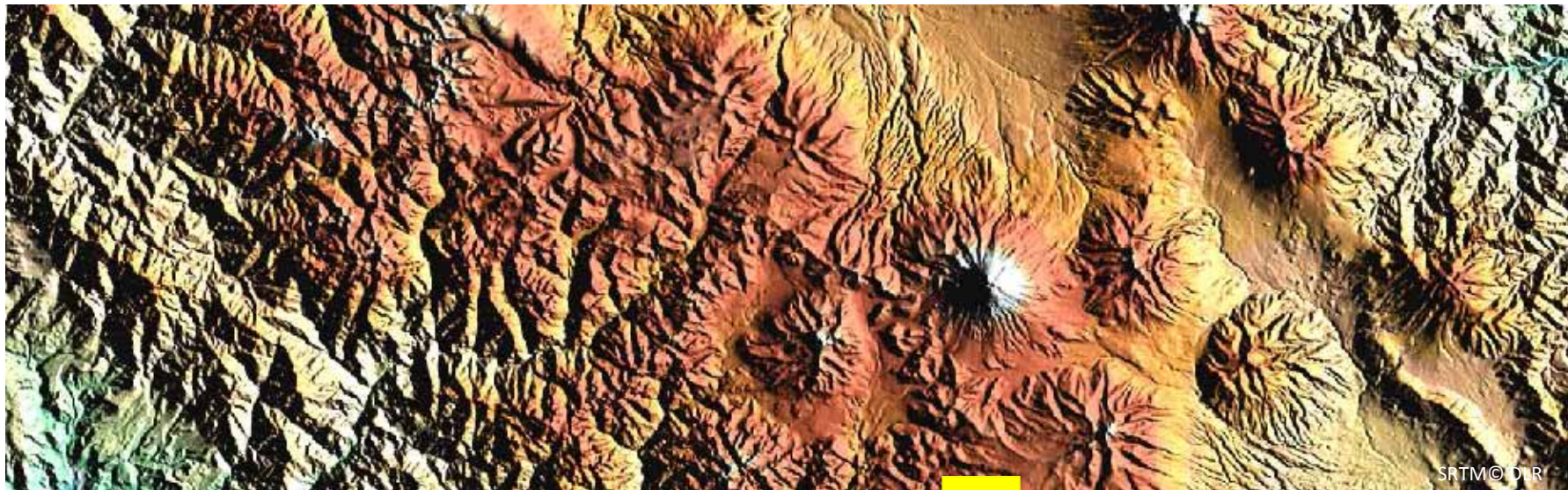

Volcano Cotopaxi
Ecuador



geocoded

GLOBE
resolution
1 km x 1 km



SRTM
InSAR
resolution
25 m x 25 m

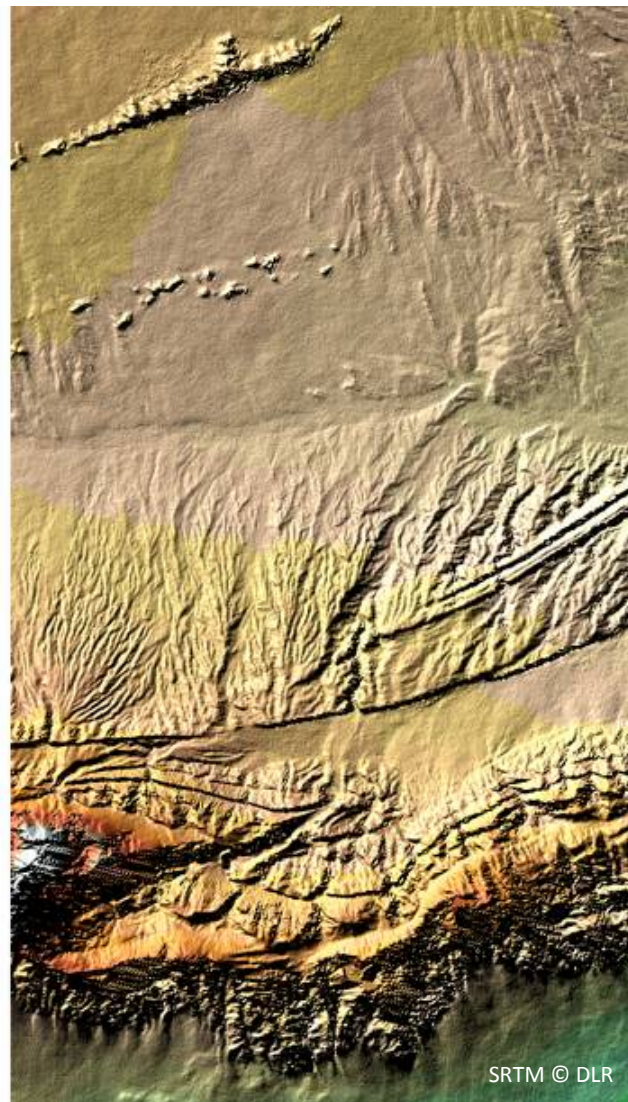

TanDEM-X

Germany's current
Earth Observation Mission

- Two satellites in close constellation
- Variable across track baseline -> DEMs
- Variable along track baseline -> ATI
- Main mission goal: global HRTI-3 DEM

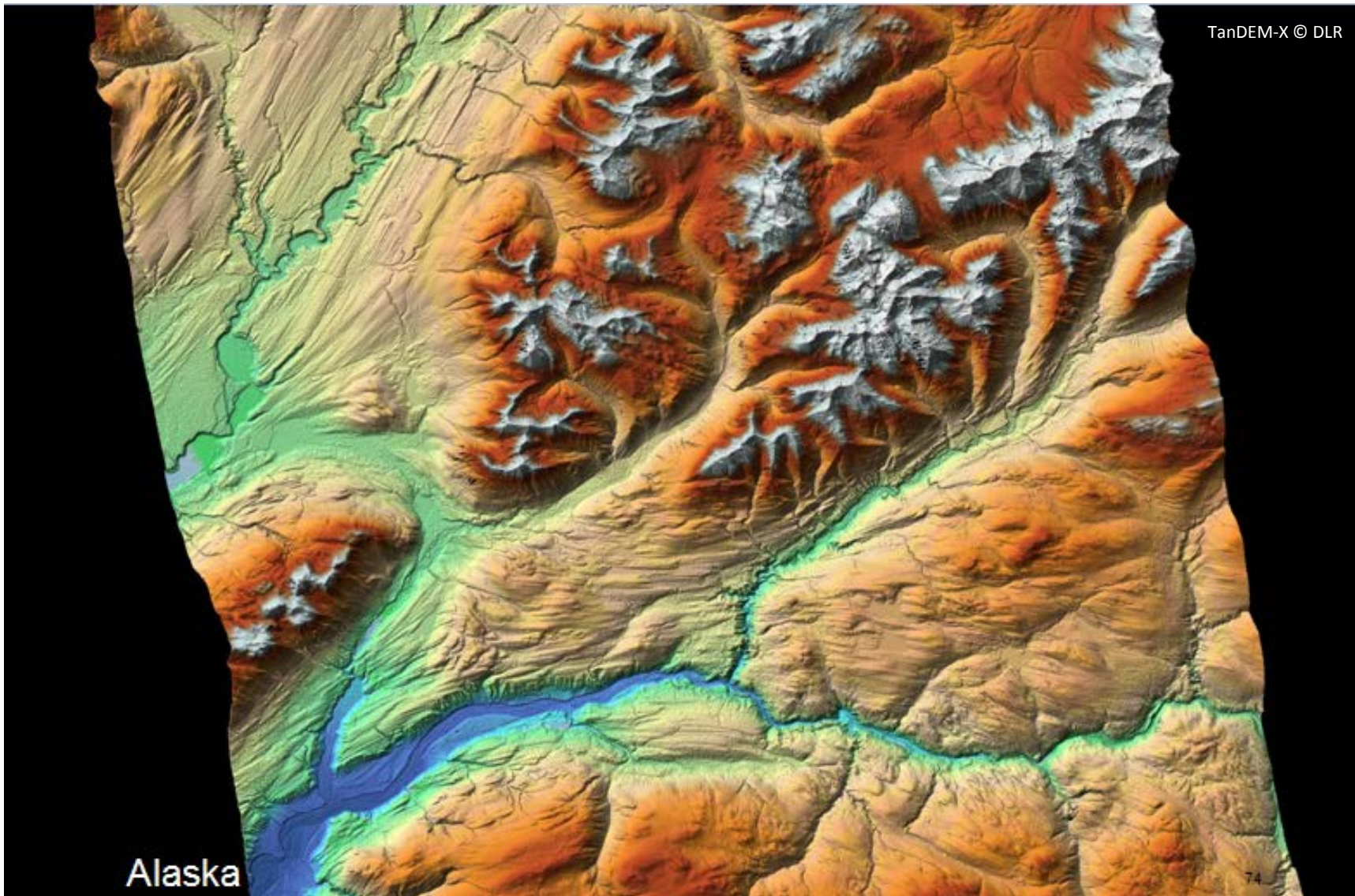

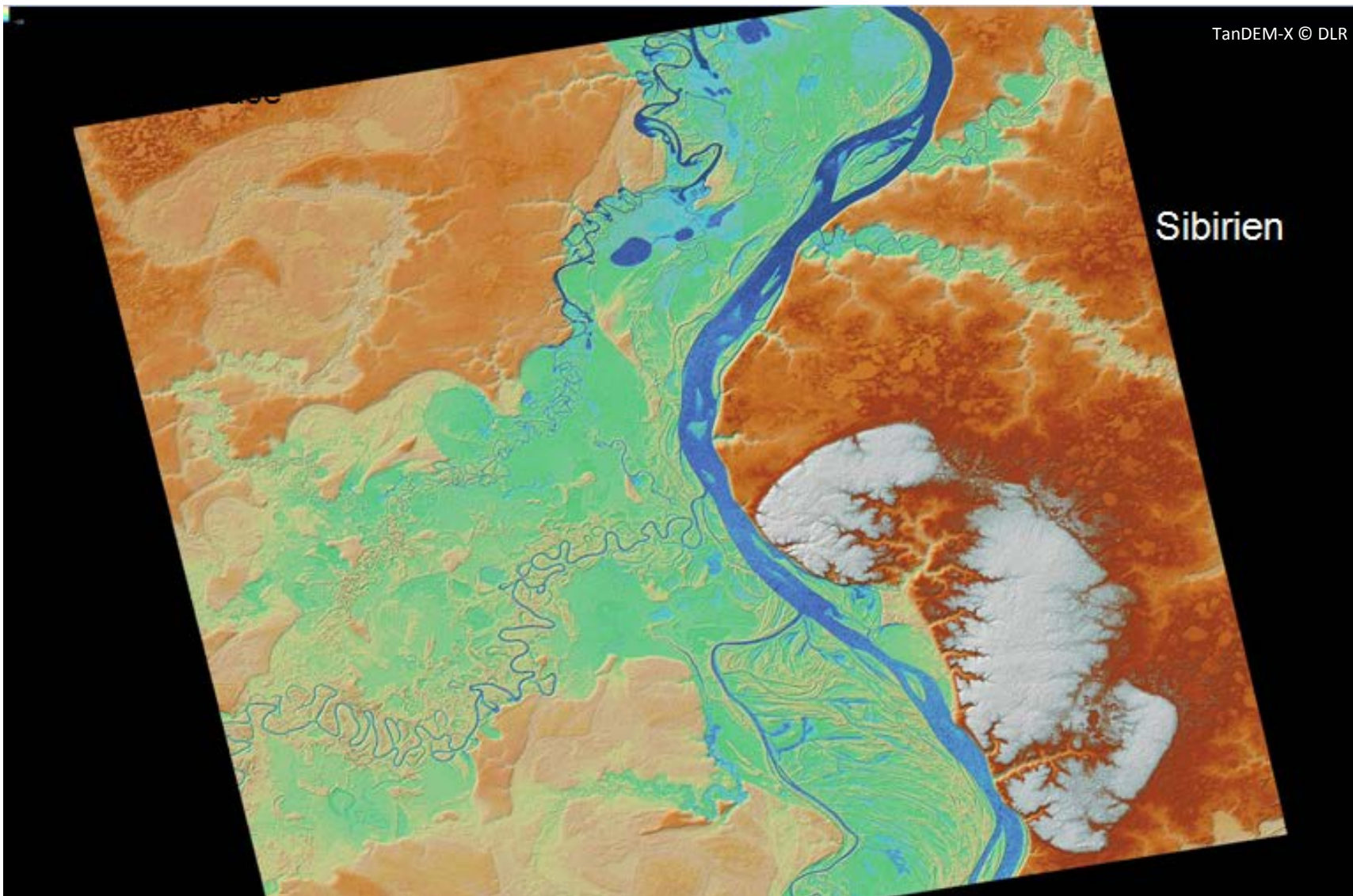

TanDEM-X Applications: open pit mining

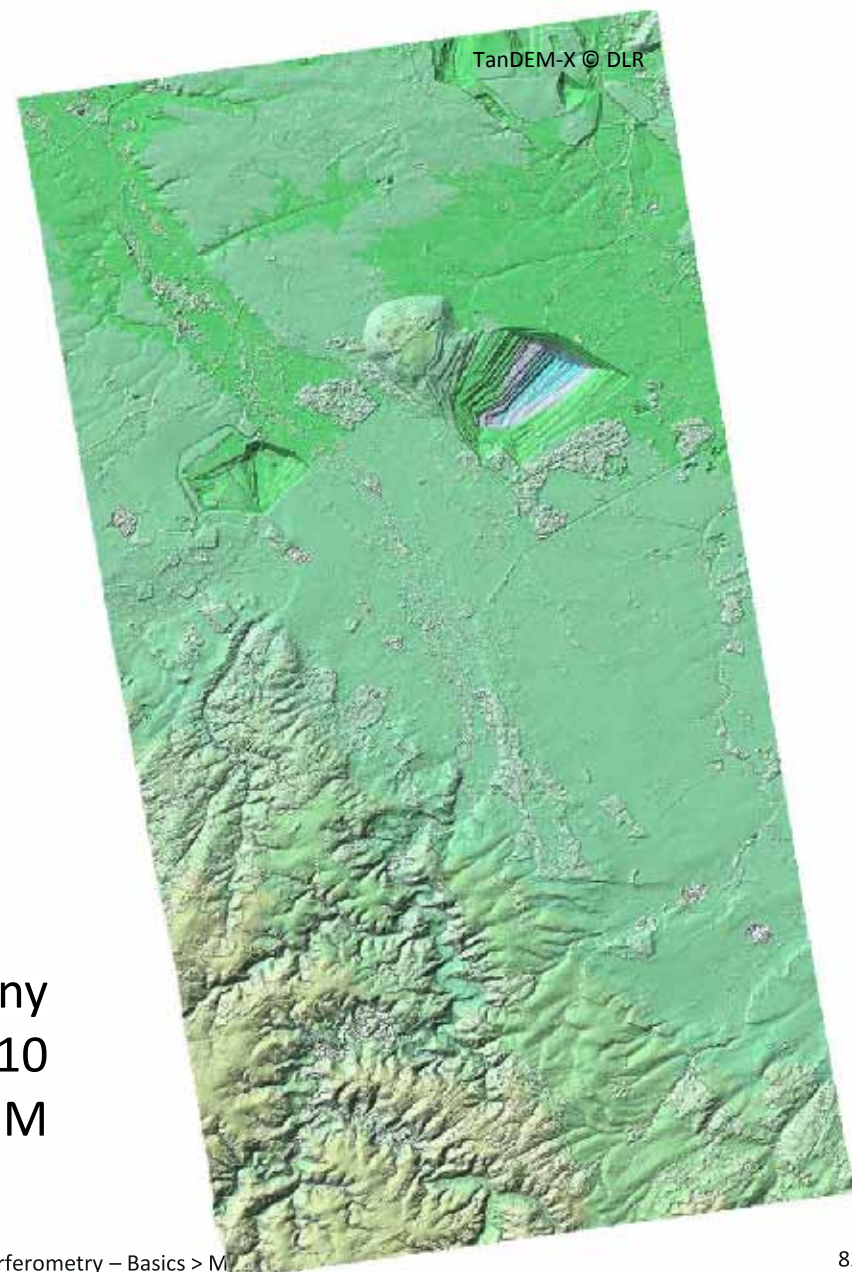

Hambach, Germany
12/2010
TanDEM-X Raw-DEM

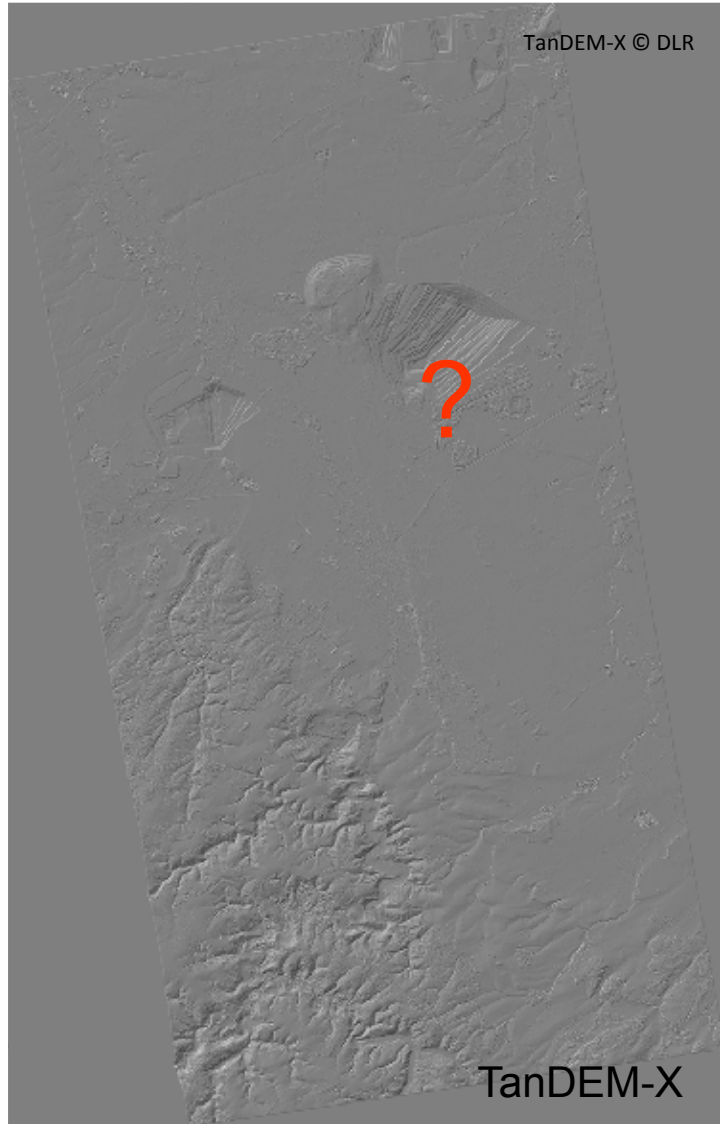
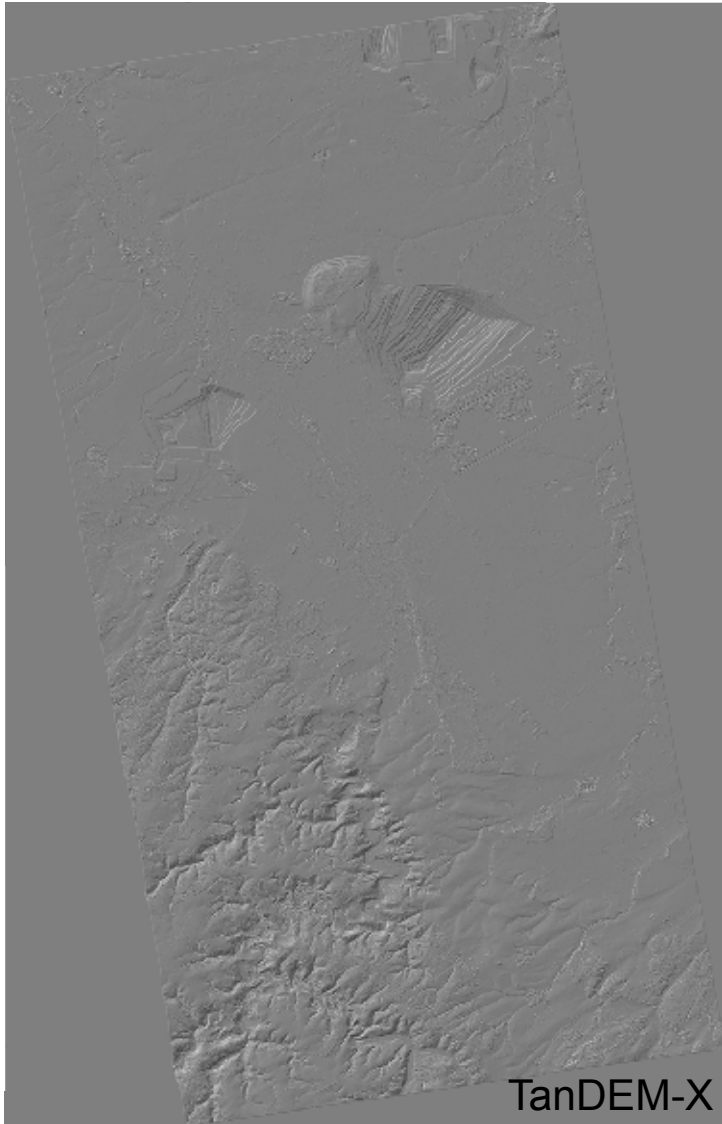

TanDEM-X DEM und and Changes since SRTM 2000

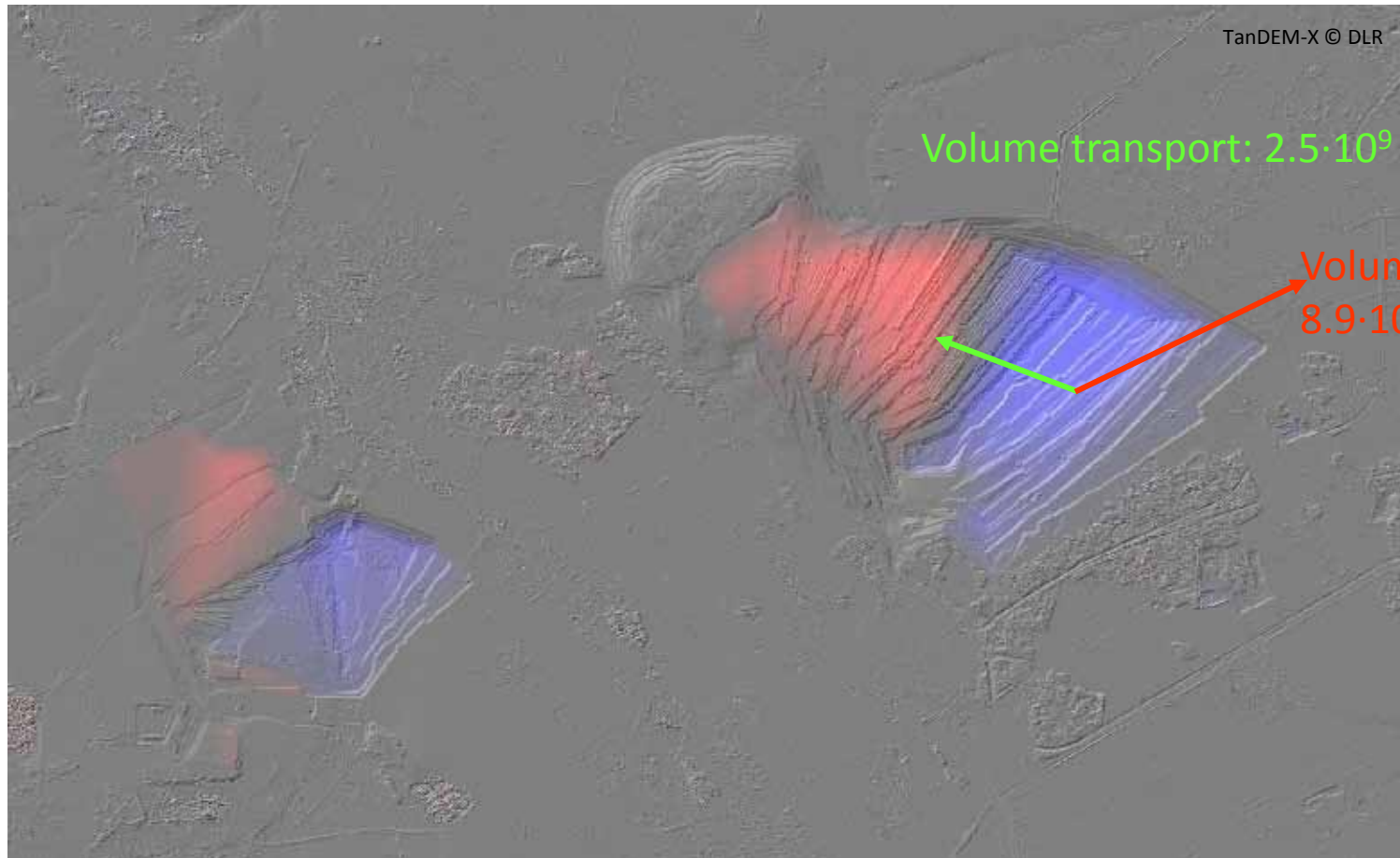

Sentinel-1 TOPS Mode (2014)

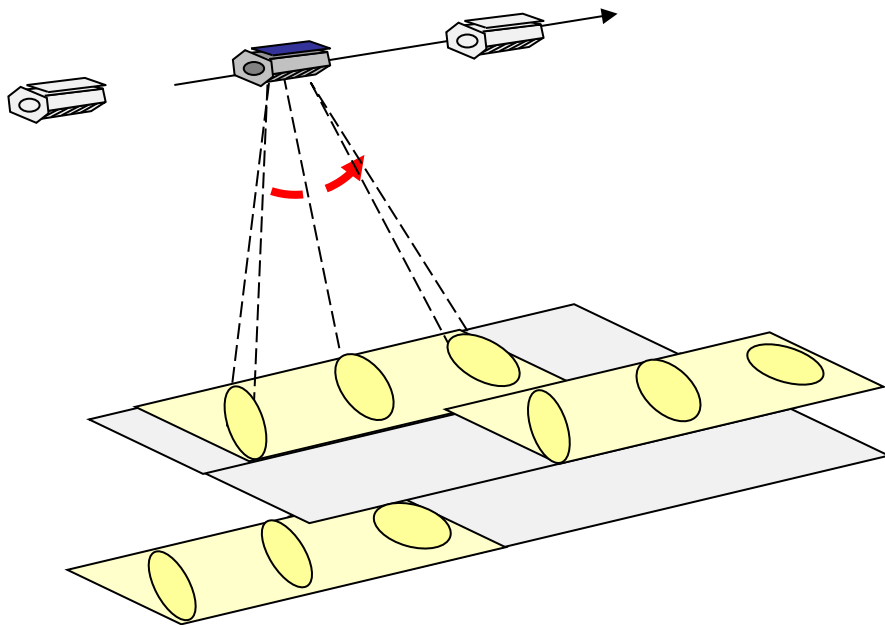

TOPS: Reduce aperture time by steering the antenna electronically **forward** in azimuth

- More azimuth distance, less illumination time per target
- Saved time can be used to electronically steer the antenna to other elevation directions

→ increased swath width (e.g. S1: $3 \times = 250$ km)

→ reduced resolution (e.g. S1: 20 m)

S1-A launched 2014, S1-B launched 2016

De Zan, F.; Monti Guarnieri, A., "TOPSAR: Terrain Observation by Progressive Scans," Geoscience and Remote Sensing, IEEE Transactions on , vol.44, no.9, pp.2352,2360, Sept. 2006

Italy –

n Se

TOP

erogram



Master Calibrated Amplitude



Coherence

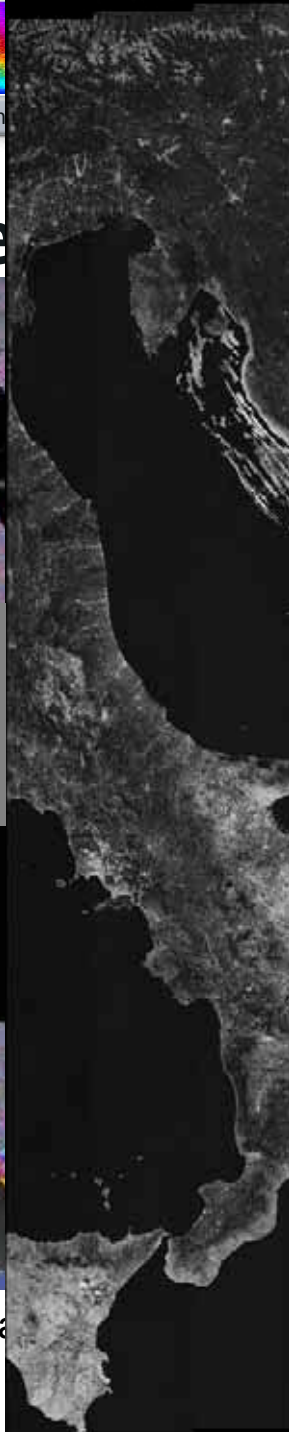

Calibrated Amplitude Interferogram Overlay

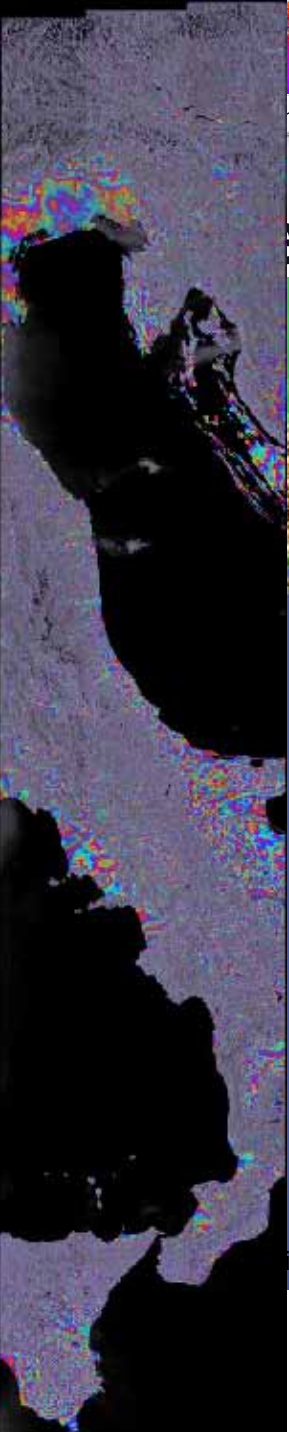
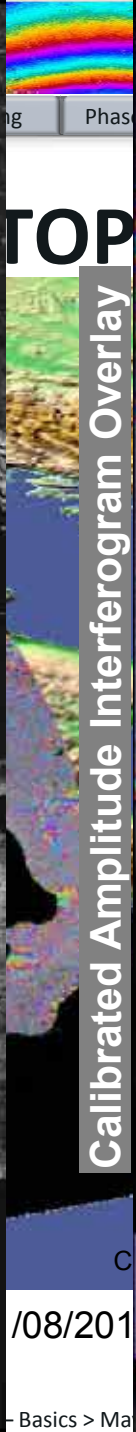

Nepal Earthquake, April 2015, M 7.8

Line-of-Sight Displacement

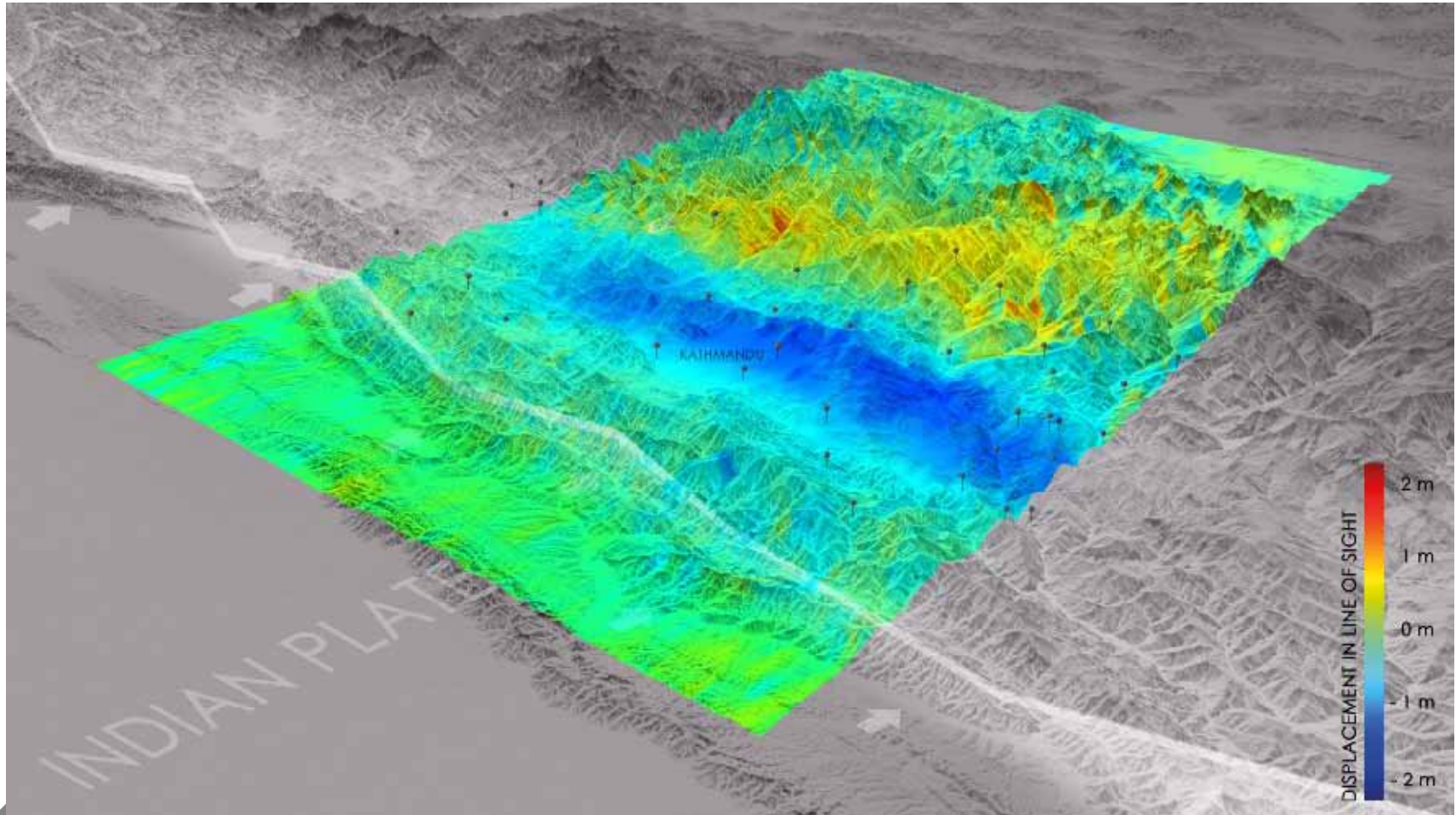

Contains modified Copernicus Sentinel data 2015 / DLR

Sentinel-1 Wide Area PSI – Mexico Linear Deformation

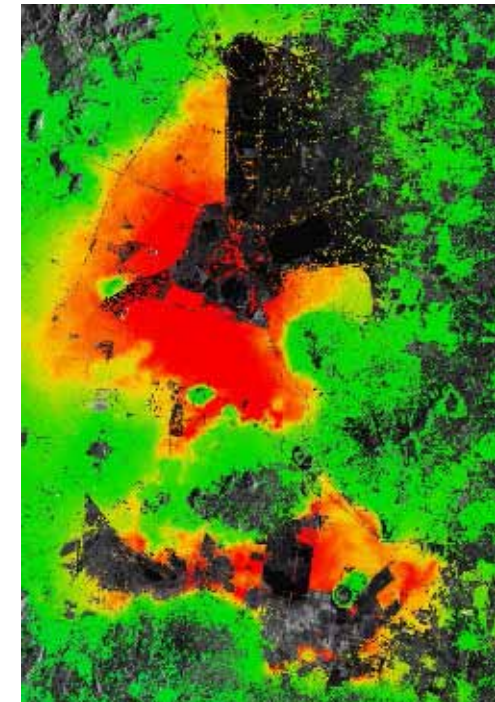
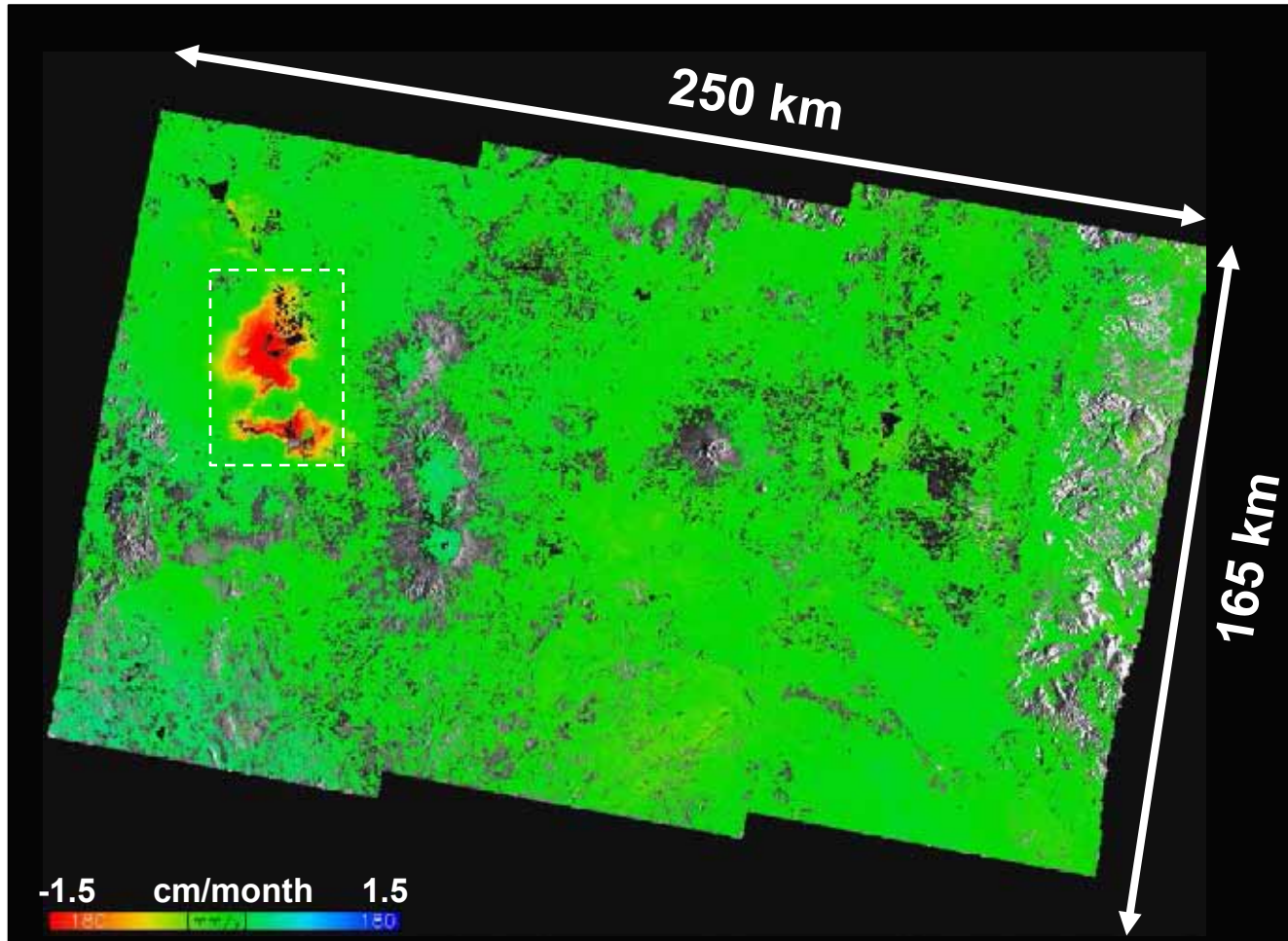

21 IW SLCs, VV, Descending

Time span: 2014-10-03

2015-06-24

Contains modified Copernicus Sentinel data 2014-2015 / DLR

European Tectonic Areas DInSAR Coherence Map

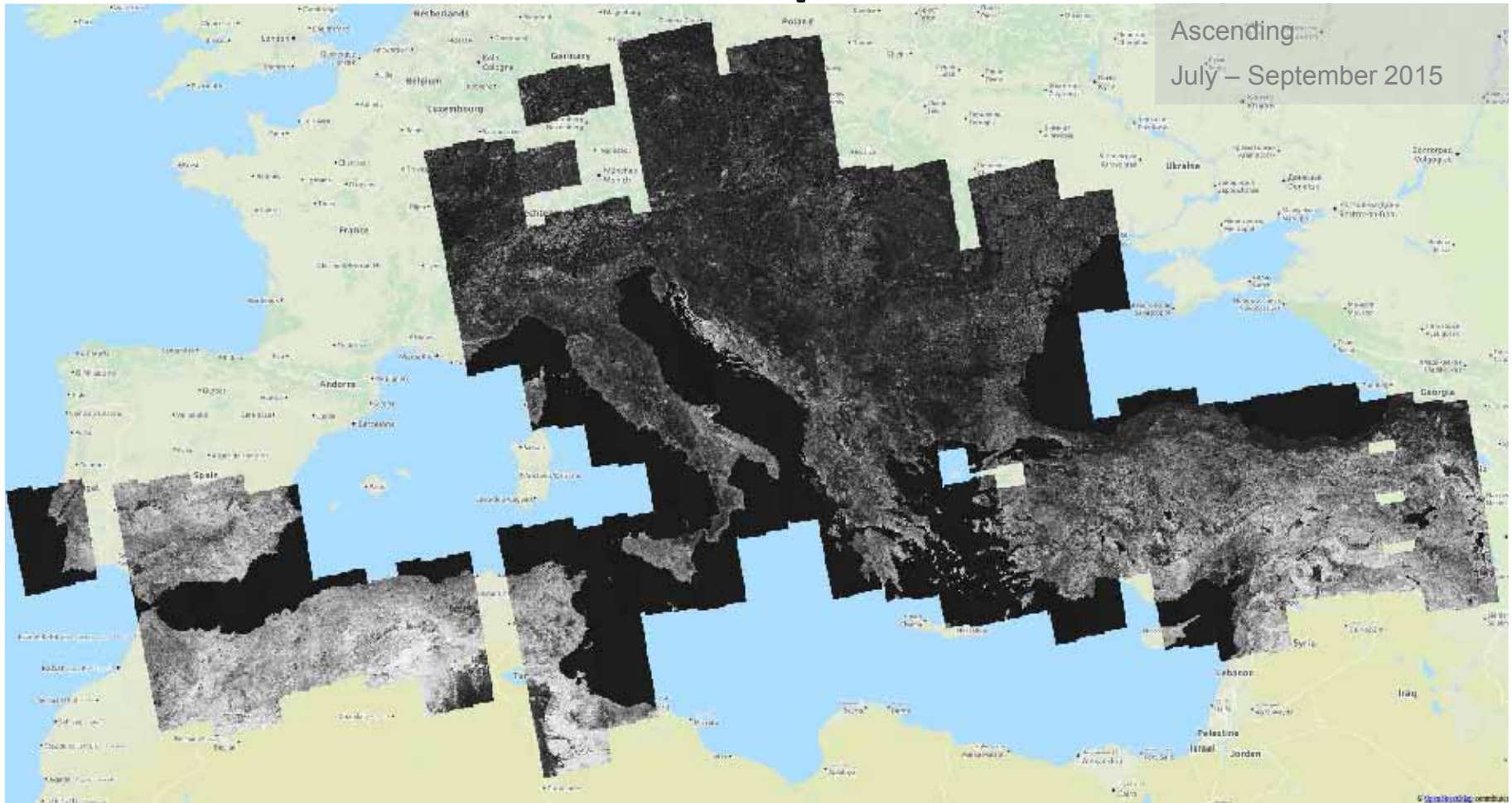

Coherence maps: Contains modified Copernicus Sentinel data 2015 / DLR

Background map: © OpenStreetMap contributors

Japan Earthquake, April 2016, M 7.0

DInSAR Phase

Descending, Master 2016-03-27, Slave 2016-04-20

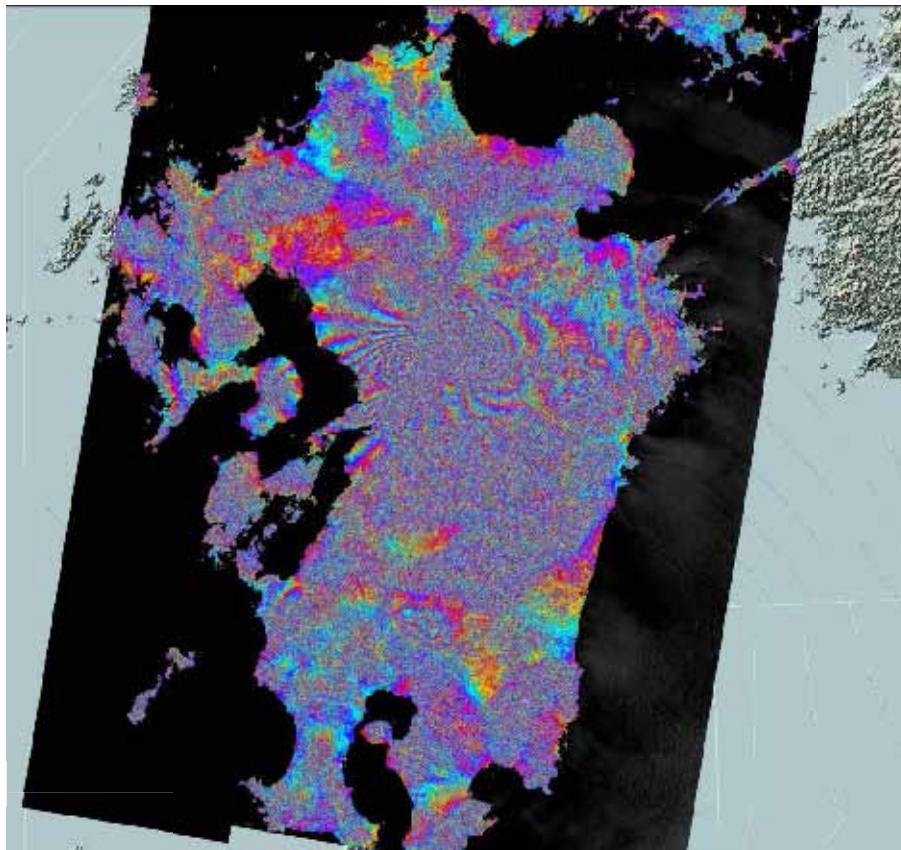

Ascending, Master 2016-04-08, Slave 2016-04-20

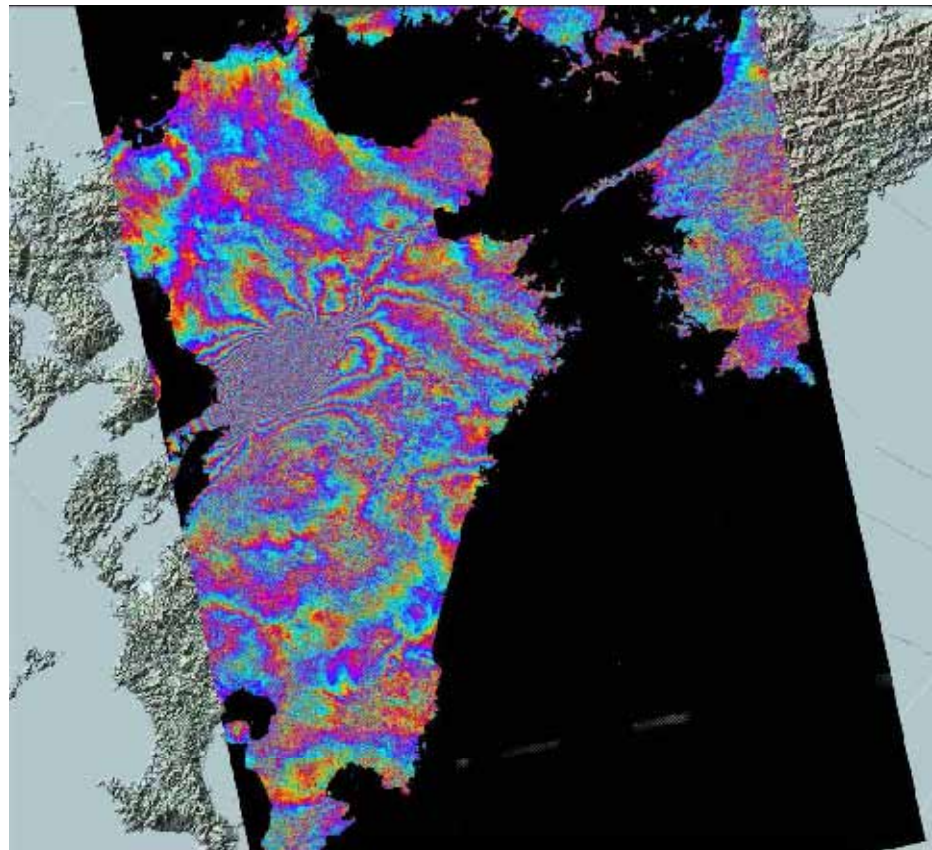

Contains modified Copernicus Sentinel data 2016 / DLR

SAR Satellites in 2016



TerraSAR-X (D)



TanDEM-X (D)

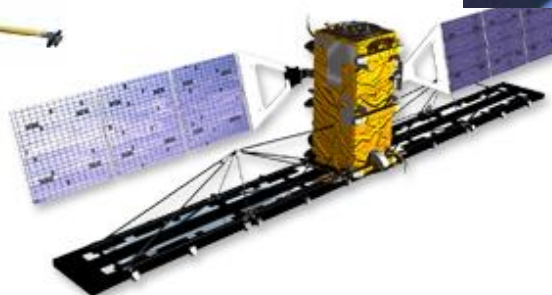

Radarsat-2 (CAN)

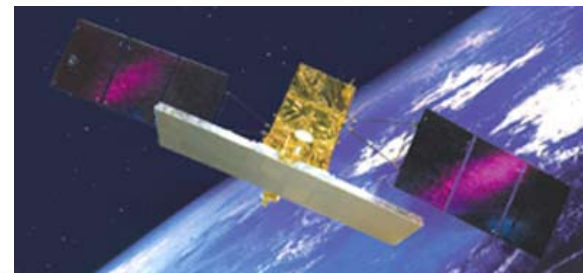

COSMO/SkyMed (I)



ALOS-2 (J)



ESA Sentinel-1

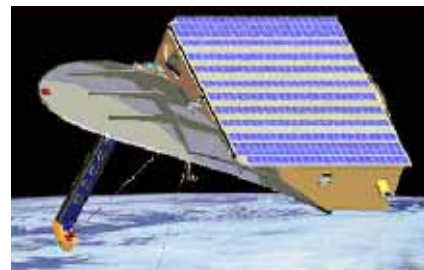

SARLupe (D)



Fig. 22: © DLR

Some SAR/InSAR Processing Software (2016)

Commercial

- GAMMA software (Switzerland) <http://www.gamma-rs.ch/>
- EarthView® InSAR (PCI Geomatics, Canada) <http://www.pcigeomatics.com/>
- SARscape for ENVI (Exelis, USA) <http://www.exelisvis.com/ProductsServices/ENVI/ENVISARscape.aspx>
- ERDAS IMAGINE <http://www.geosystems.de/>

Public Domain

- Alaska SAR facility (ASF, USA) <http://www.asf.alaska.edu/>
- ROI_PAC (NASA/JPL, USA) <https://www.openchannelsoftware.com/>
- Doris (Delft University, The Netherlands) <http://doris.tudelft.nl/>
- StaMPS/MTI (Delft University, The Netherlands) <http://radar.tudelft.nl/~ahoopier/stamps/>

Some SAR/InSAR Processing Software (2016)

Public Domain (ff.)

- NEST (Next ESA SAR Toolbox, ESA)
- SNAPHU (Stanford University, USA)

<http://nest.array.ca/web/nest>

<http://web.stanford.edu/group/radar/softwareandlinks/sw/snaphu/>

Research Organizations

- GENESIS (DLR, Germany)
- Diapason (CNES, France)

<http://www.altamira-information.com>



References

- Goldstein, R. M., Zebker, H. A., & Werner, C. L. (1988). Satellite radar interferometry: Two-dimensional phase unwrapping. *Radio Science*, 23(4), 713-720.
- Graham, L. C. (1974). Synthetic interferometer radar for topographic mapping. *Proceedings of the IEEE*, 62(6), 763-768.
- Lang O, Rabus BT and Dech SW (2004) Velocity map of the Thwaites Glacier catchment, West Antarctica, *J. Glaciol.*, 50(168), 46–56.
- Massonnet, D., Rossi, M., Carmona, C., Adragna, F., Peltzer, G., Feigl, K., & Rabaute, T. (1993). The displacement field of the Landers earthquake mapped by radar interferometry. *Nature*, 364, 138-142.
- Romeiser, R., Breit, H., Eineder, M., Runge, H., Flamant, P., Karin, J., Vogelzang, J. (2003) Validation of SRTM-Derived Surface Currents off the Dutch Coast by Numerical Circulation Model Results. Proceedings of IGARSS 2003, Toulouse.
- Small, D., Meier, E., Jonsson, S., & Nüesch, D. (2005). ScanSAR InSAR Processing of ASAR Wide Swath SLC (WSS) Products (Abstract). In: *Proceedings of the Fringe ATSR Workshop*, December 2, 2005, Frascati, Italy.
- Suchandt, S., Runge, H., Breit, H., Kotenkov, A., Wehling, D., Hinz, S. (2008). Traffic Measurement with TerraSAR-X: Processing System Overview and First Results, EUSAR 2008, Friedrichshafen, Germany
- Vietmeier, J., Wagner, W., Dikau, R. (2000). Monitoring Moderate Slope Movements (Landslides) in the Southern French Alps Using Differential SAR Interferometry, Proceedings FRINGE'99, Liège, Belgium, 10 - 12 November 1999.

SAR-EDU – SAR Remote Sensing Educational Initiative

<http://sar-edu.uni-jena.de/index.html>

Supported by:



Federal Ministry
of Economics
and Technology

on the basis of a decision
by the German Bundestag

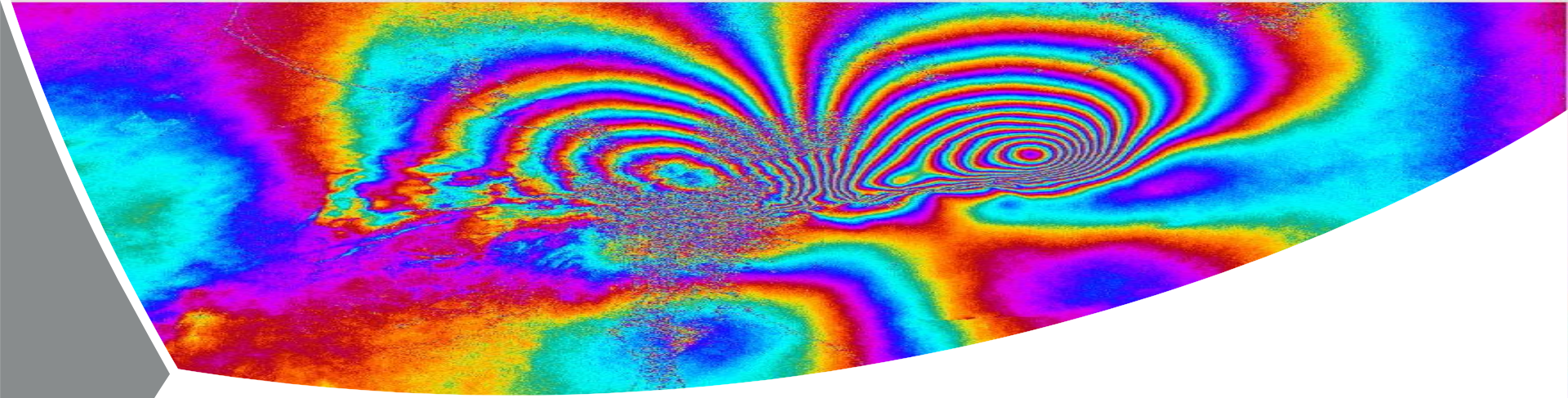

Athena Summer School – SAR SAR Interferometry – Error Sources May 2016

Material :

Michael Eineder, Richard Bamler

Remote Sensing Technology (TUM/DLR)

Content of SAR Interferometry

- Basics
- Error sources

Educational Objective

- Understand SAR interferometry in more detail for quantitative work
- Know major error sources of InSAR
- Know some crucial processing steps to improve coherence

Further Reading

Books

- Hanssen, R. F. (2001). *Radar Interferometry: Data Interpretation and Error Analysis* (Remote Sensing and Digital Image Processing Series, Vol. 2). Dordrecht: Springer Netherlands.
- Kampes, B. M. (2006). *Radar Interferometry: Persistent Scatterer Technique*. (Remote Sensing and Digital Image Processing Series, Vol. 12). Dordrecht: Springer Netherlands.

Papers

- Bamler, R., & Hartl, P. (1998). Synthetic aperture radar interferometry. *Inverse Problems*, 14, R1-R54.
- Rosen, P., Hensley, S., Joughin, I. R., Li, F. K., Madsen, S. N., Rodriguez, E., & Goldstein, R. M. (2000). Synthetic Aperture Radar Interferometry. *Proceedings of the IEEE*, 88(3): 333-382.

Structure

- Interferometric phase error sources
- Coherence and phase errors
- Geometric accuracy
- Distributed scatterers (geometric decorrelation)
- Temporal decorrelation
- Atmospheric errors
- Persistent Scatterer Interferometry
- Bistatic systems (TanDEM-X)

Structure

- Interferometric phase error sources
- Coherence and phase errors
- Geometric accuracy
- Distributed scatterers (geometric decorrelation)
- Temporal decorrelation
- Atmospheric errors
- Persistent Scatterer Interferometry
- Bistatic systems (TanDEM-X)

Interferometric Phase Error Sources

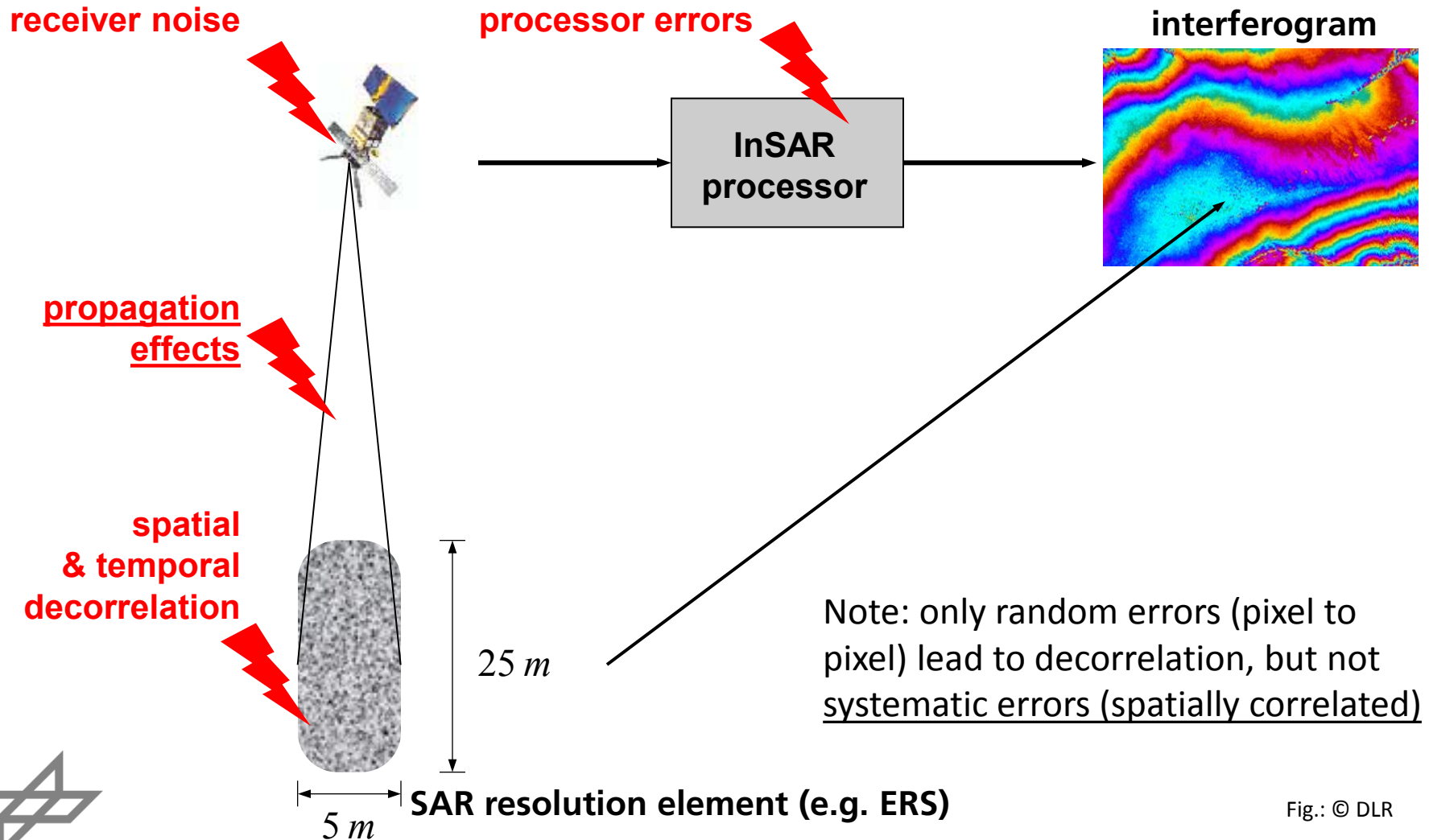

Structure

- Interferometric phase error sources
- Coherence and phase errors
- Geometric accuracy
- Distributed scatterers (geometric decorrelation)
- Temporal decorrelation
- Atmospheric errors
- Persistent Scatterer Interferometry
- Bistatic systems (TanDEM-X)

Interferometric Coherence for Image Interpretation

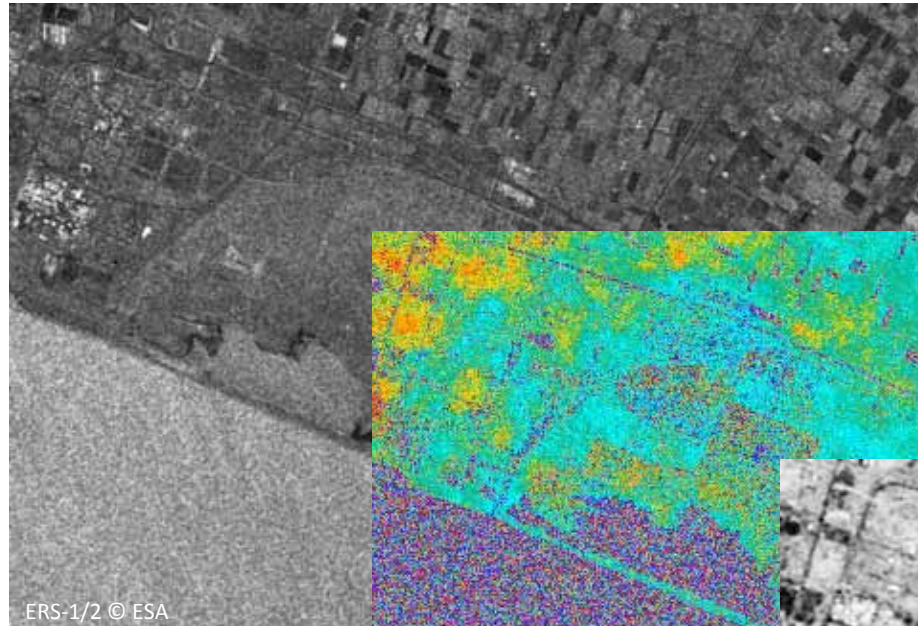

Flevoland, NL

SAR image

interferometric phase

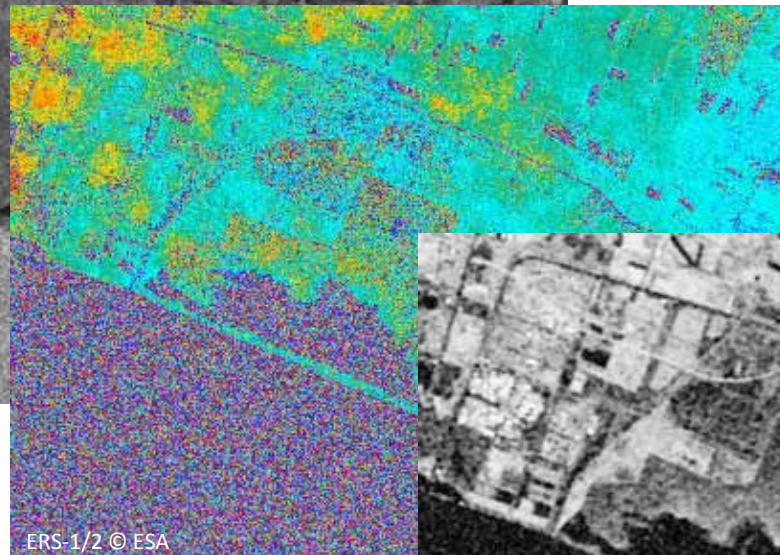

coherence



Coherence - A Measure of Interferogram Quality (repetition)

➤ correlation coefficient between the two complex SAR images u_1 and u_2

$$\gamma = \frac{E\{u_1 u_2^*\}}{\sqrt{E\{|u_1|^2\} E\{|u_2|^2\}}}$$

➤ coherence estimate:

$$|\hat{\gamma}[i, k]| = \frac{\left| \sum_W u_1[i, k] u_2^*[i, k] \right|}{\sqrt{\sum_W |u_1[i, k]|^2 \sum_W |u_2[i, k]|^2}}$$

W : small window centered around pixel $[i, k]$

Typical window size: 5 – 100 pixels

Stationarity within window assumed!

Bias of Coherence Estimate as a Function of Window Size

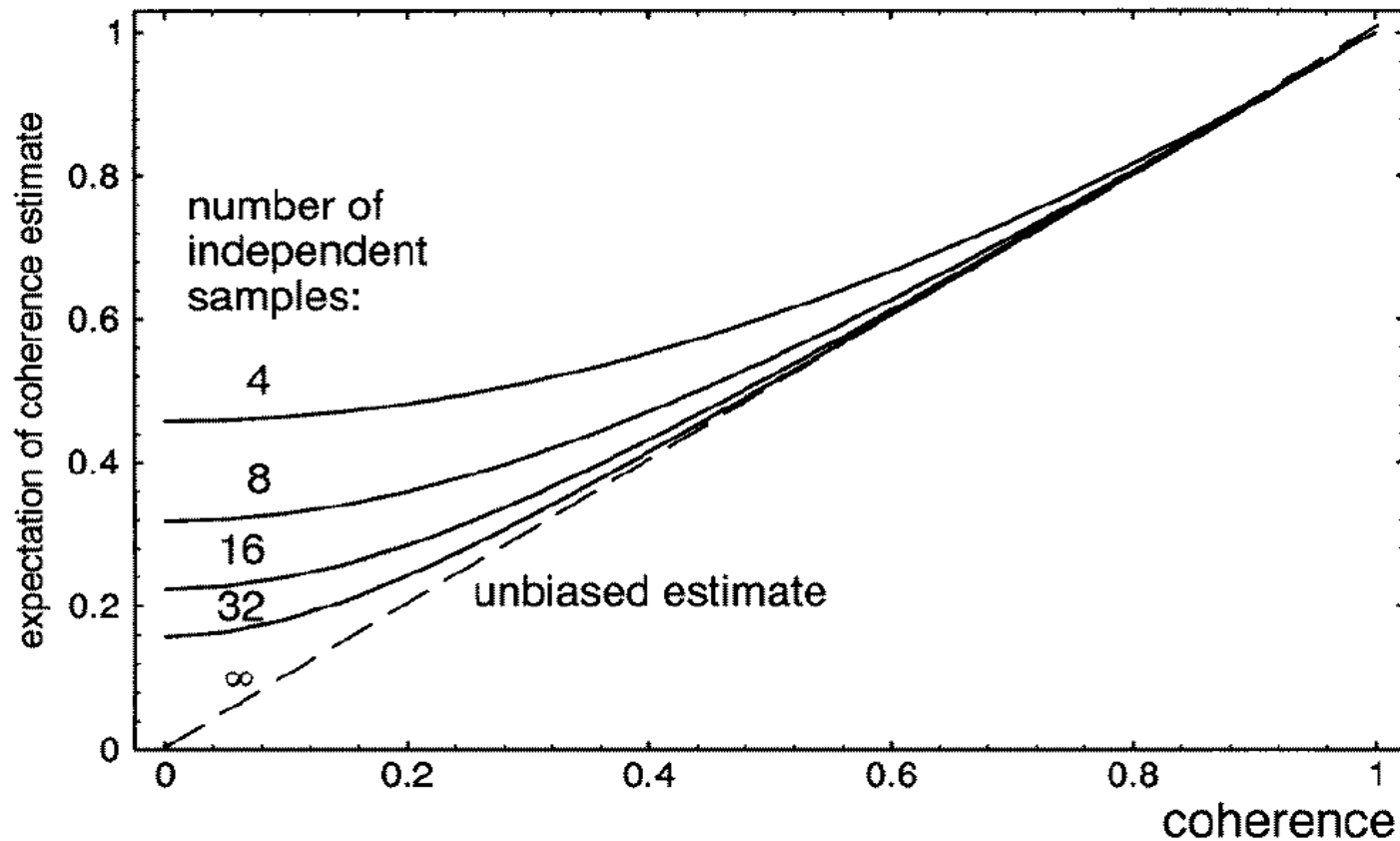
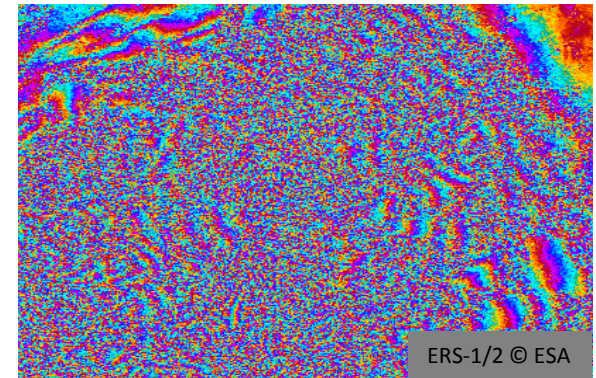
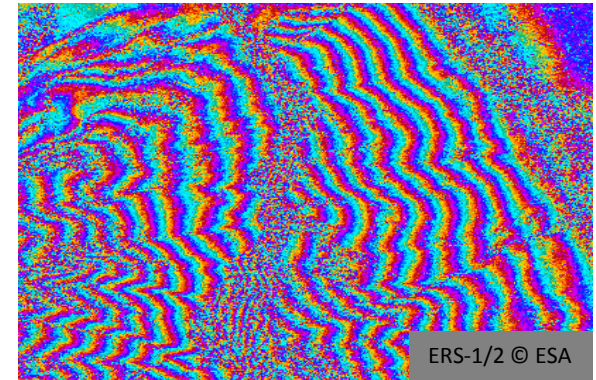
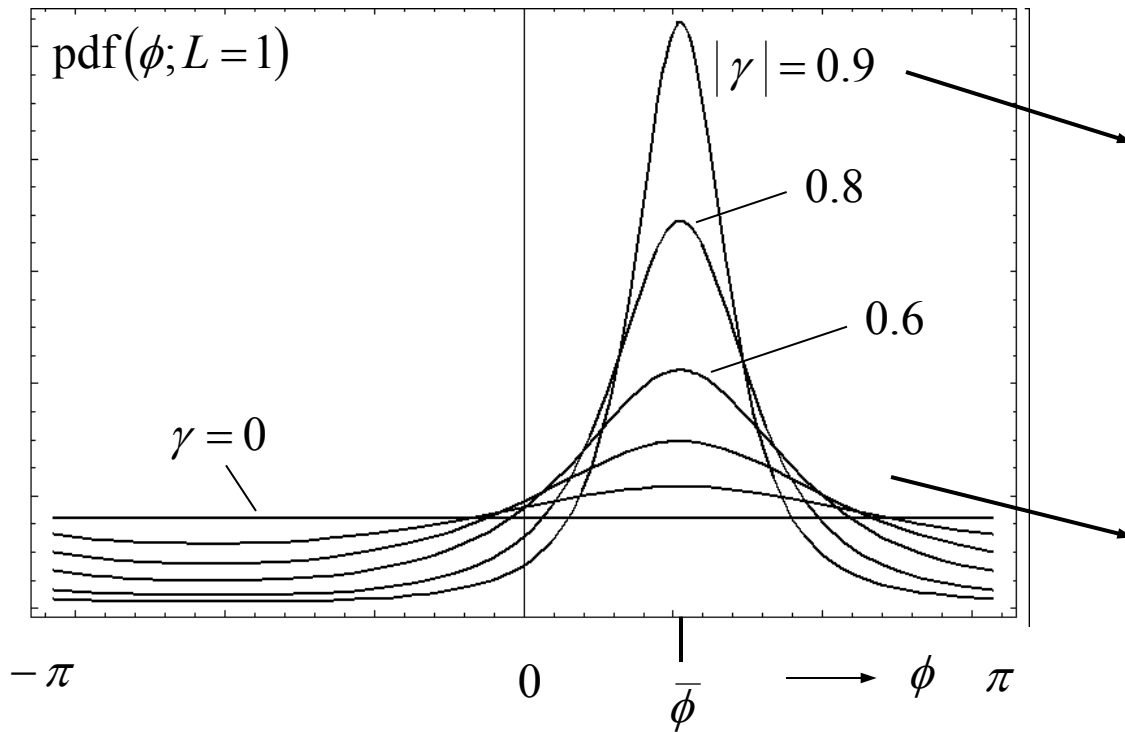

Fig.: © DLR

Analytic Phase PDF as a Function of Coherence and Number of Averaged Samples (Looks) L



$$\text{pdf}(\phi; L) = \frac{\Gamma(L + 1/2) (1 - |\gamma|^2)^L |\gamma| \cos(\phi - \bar{\phi})}{2\sqrt{\pi} \Gamma(L) (1 - |\gamma|^2 \cos^2(\phi - \bar{\phi}))^{L+1/2}} + \frac{(1 - |\gamma|^2)^L}{2\pi} {}_2F_1(L, 1; 1/2; |\gamma|^2 \cos^2(\phi - \bar{\phi}))$$

Fig.: © DLR

Analytic Phase PDF - continued

➤ Hypergeometric function:

$${}_2F_1(a, b; c; z) = \sum_{n=0}^{\infty} \frac{(a)_n (b)_n}{(c)_n} \frac{z^n}{n!}$$

with $(a)_n = a(a+1)(a+2)\dots(a+n-1)$

➤ Gamma function:

$$\Gamma(z) = \int_0^{\infty} t^{z-1} e^{-t} dt$$
$$\Gamma(n) = (n-1)!$$

Coherence and Phase Noise - Theory

Approximation of phase error :
(Often used for larger L and good coherence)

$$\sigma^2 = \frac{1}{2L} \frac{1-\gamma^2}{\gamma^2} \frac{360^\circ}{2\pi}$$

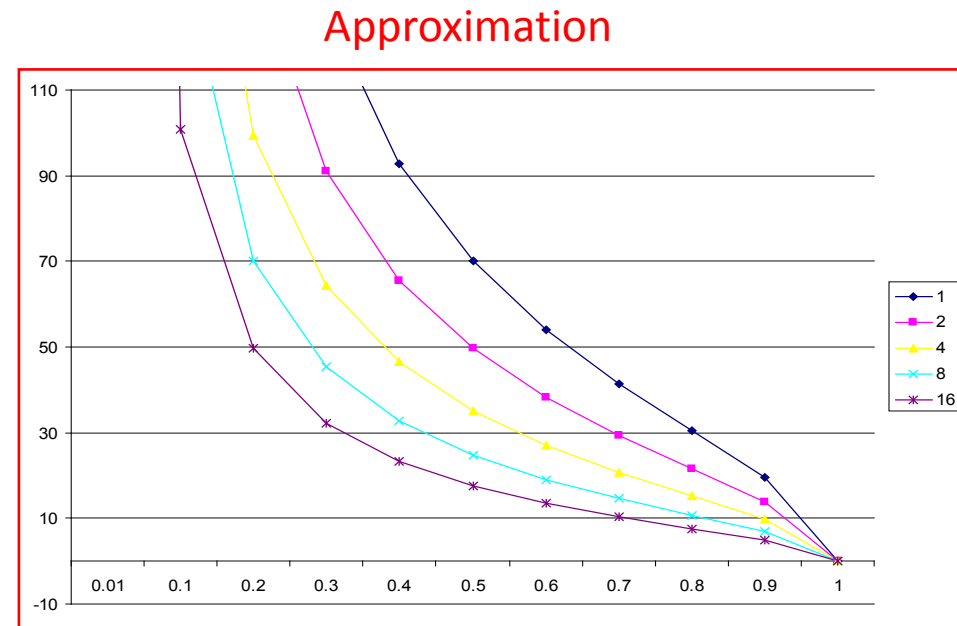
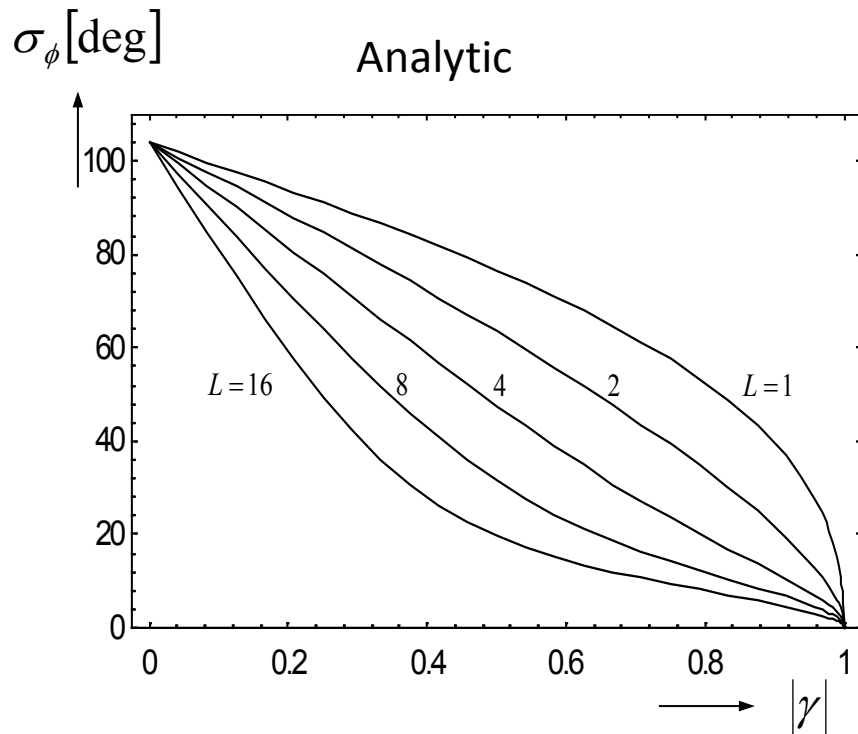

- Lower phase noise can be achieved with higher coherence (difficult) or increased number of looks (resolution loss)
- Approximation not always accurate

Decorrelation by Receiver Thermal Noise

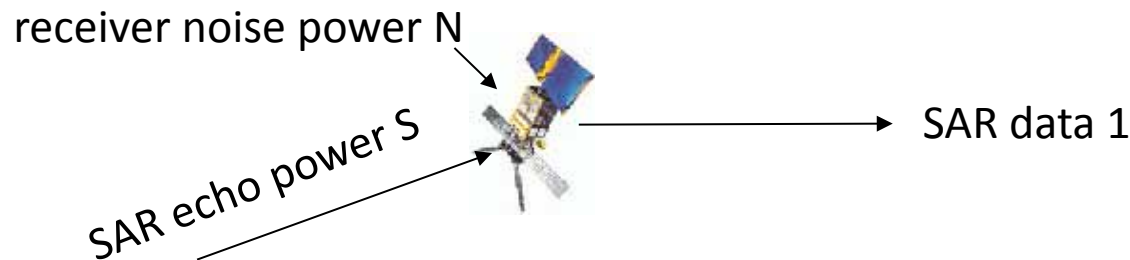

Decorrelation contribution of each channel: $\gamma_{SNR} = \frac{1}{\sqrt{1 + N_1 / S}}$

S: signal power

N: noise power

Coherence of multiple decorrelation sources:

$$\begin{aligned}\gamma &= \prod \gamma_i \\ &= \gamma_{temp} \gamma_{volume} \gamma_{SNR} \cdots \gamma_{xyz}\end{aligned}$$

Structure

- Interferometric phase error sources
- Coherence and phase errors
- **Geometric accuracy**
- Distributed scatterers (geometric decorrelation)
- Temporal decorrelation
- Atmospheric errors
- Persistent Scatterer Interferometry
- Bistatic systems (TanDEM-X)

Across-Track Interferometry

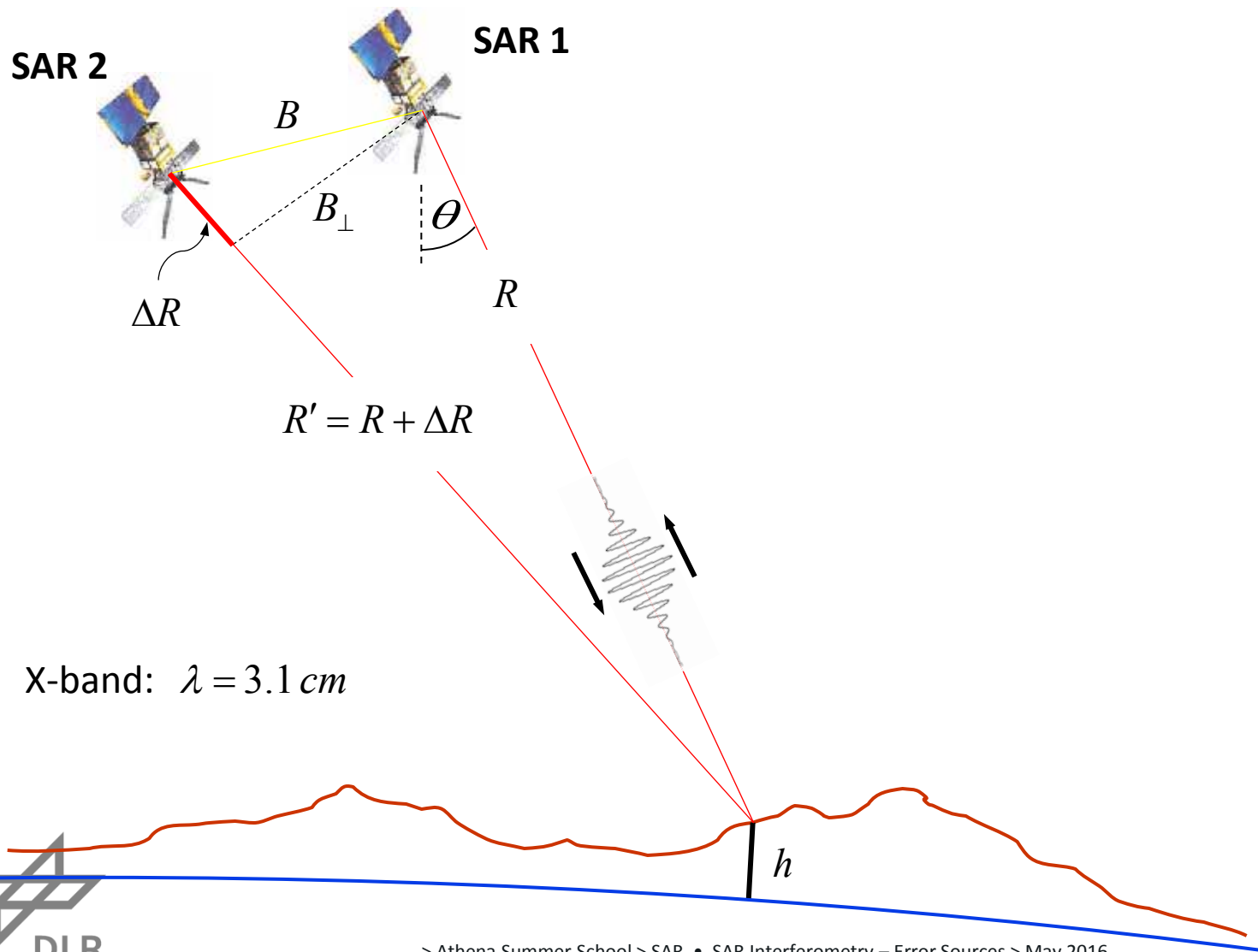
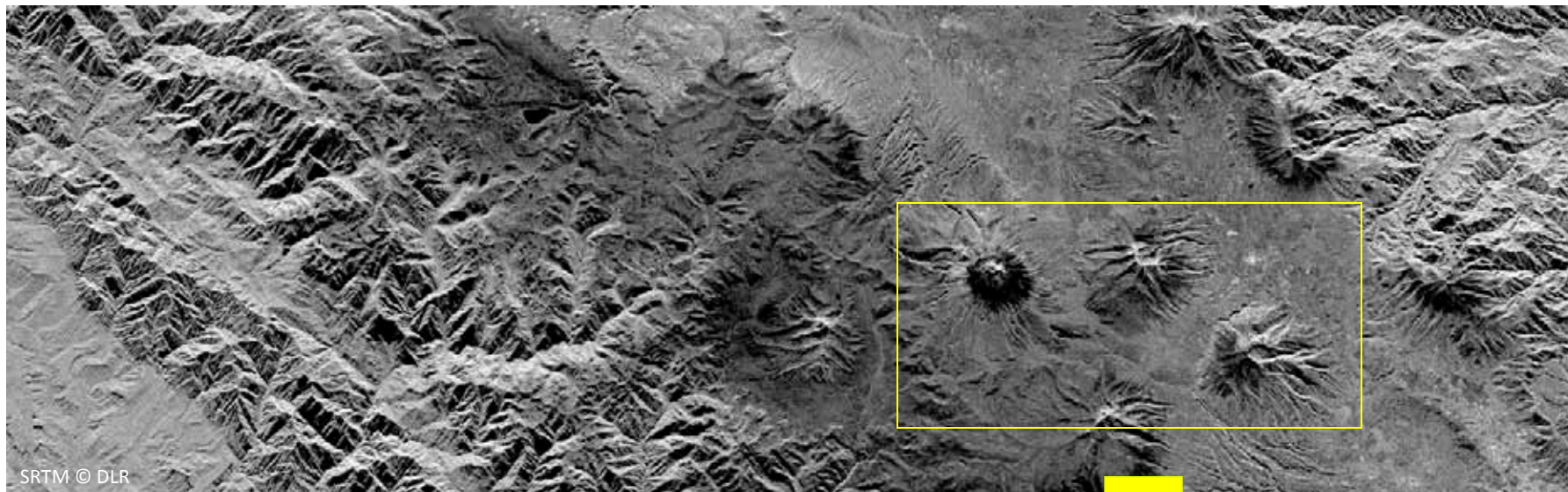
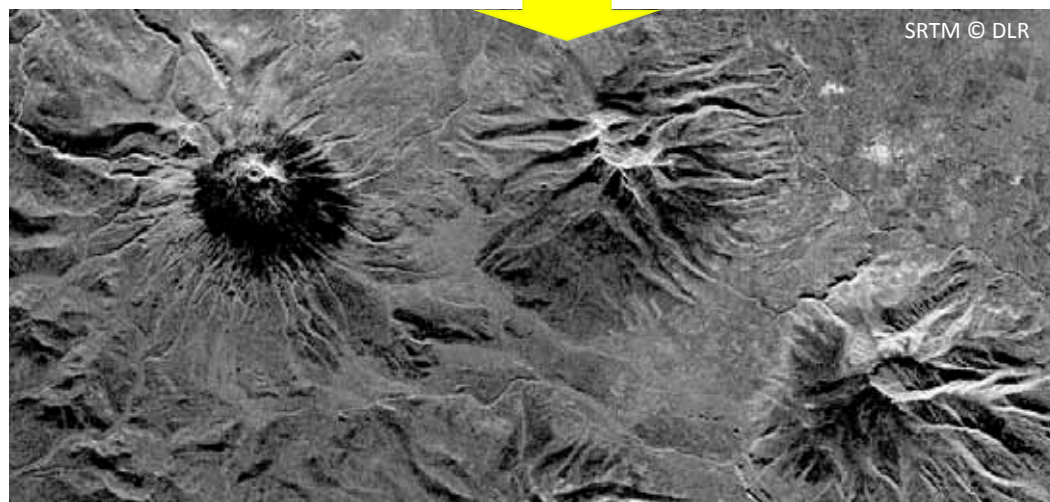

Fig.: © DLR

SRTM/X-SAR Image



Volcano Cotopaxi
Ecuador



SRTM/X-SAR Interferometric Phase

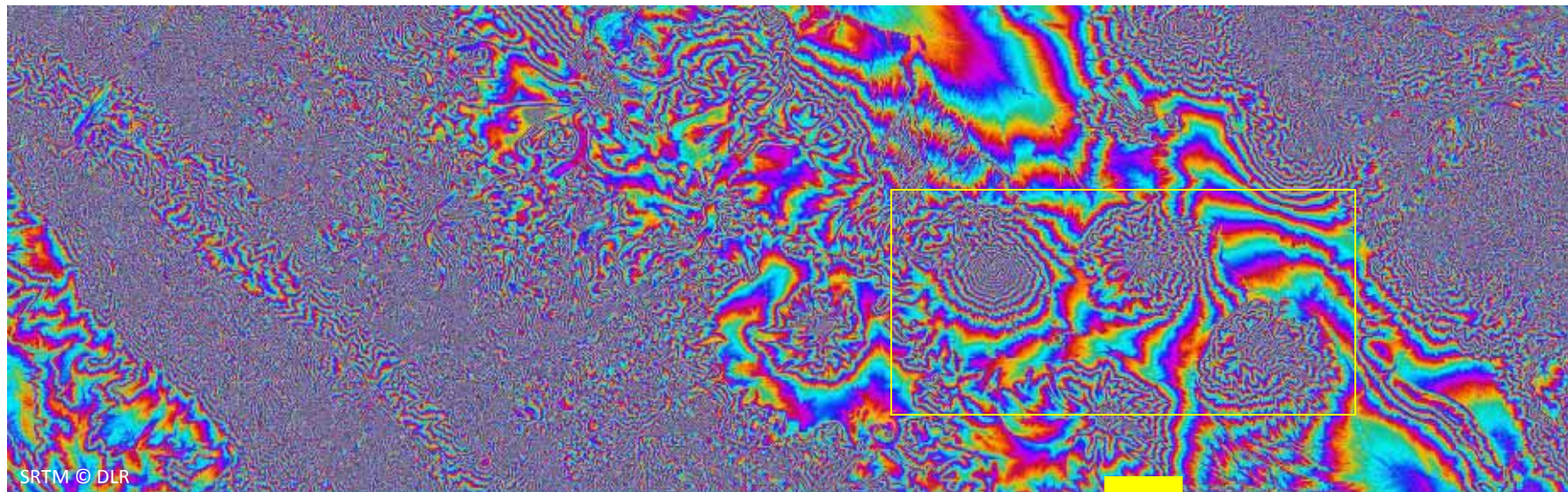

Volcano Cotopaxi
Ecuador

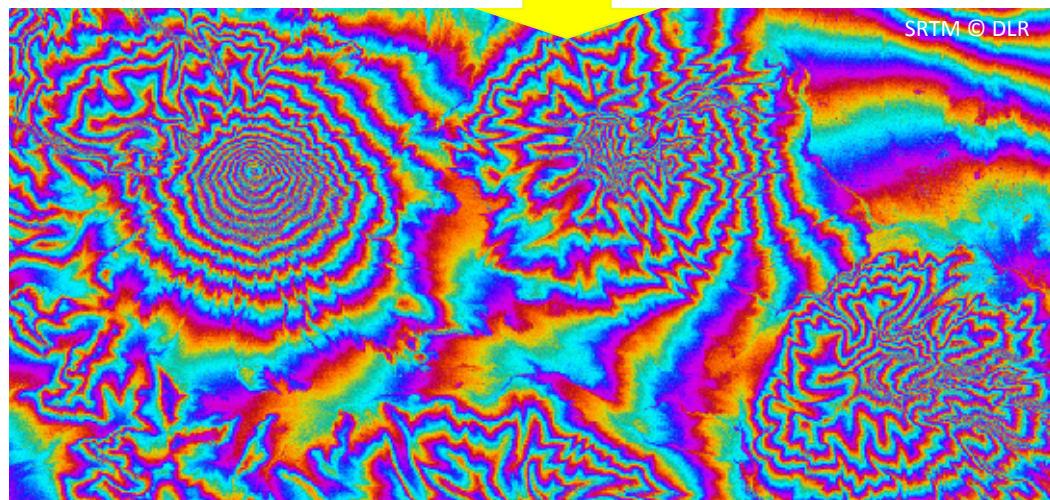

SRTM/X-SAR Digital Elevation Model



Volcano Cotopaxi
Ecuador



geocoded

Interferometry as a Measurement of Angle

3-D coordinates required: R, t, θ

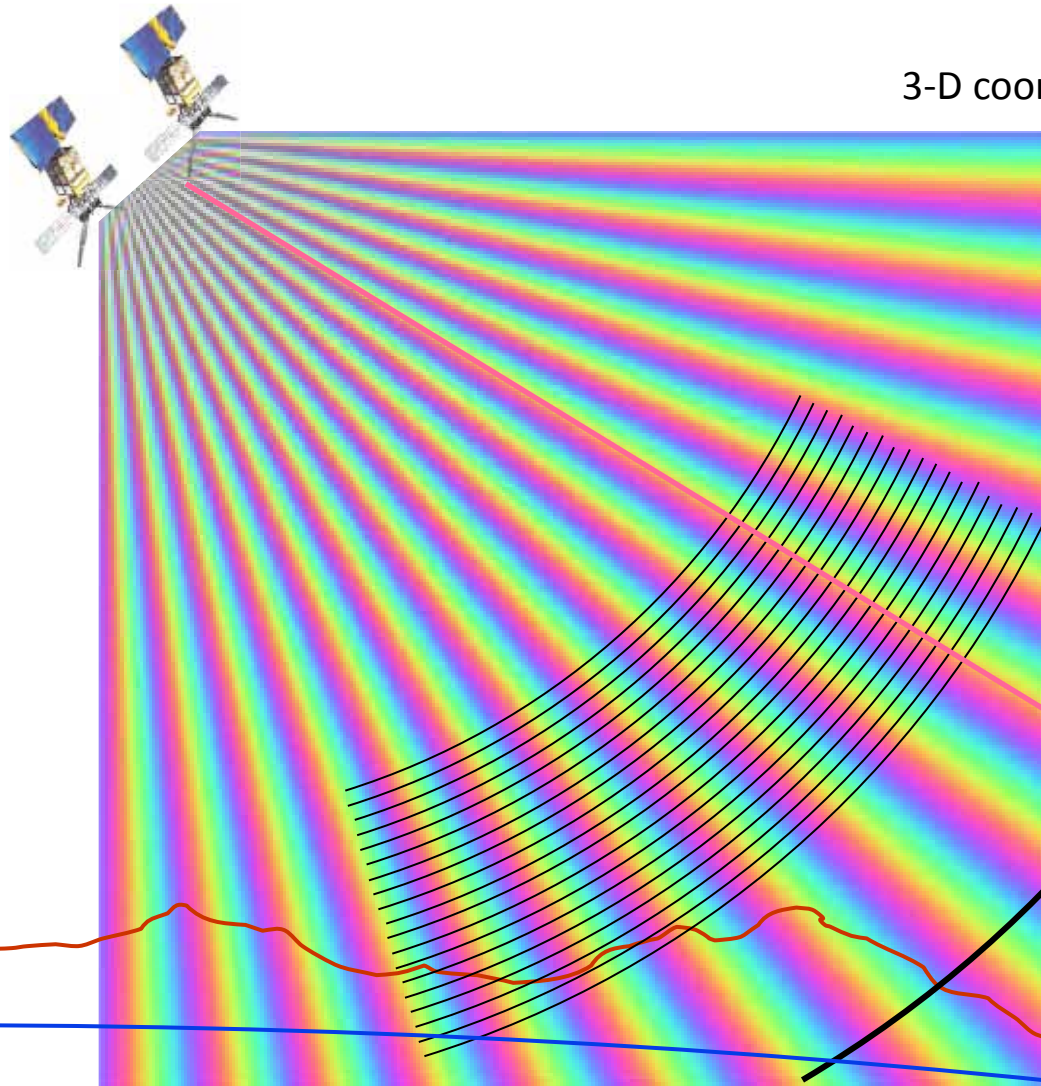

iso-range lines: $R = const$

iso-InSAR-phase lines:
 $\phi \propto \Delta R = const$

$\Delta R, \phi \propto \theta$

Fig.: © DLR

Interferometric Sensitivity

phase-to-height sensitivity: $\frac{\partial \phi}{\partial z} = \frac{4 \pi}{\lambda} \frac{B_{\perp}}{R \sin \theta}$

phase error: σ_{ϕ}
 \rightarrow height error: $\sigma_z = \frac{\sigma_{\phi}}{\partial \phi / \partial z}$

example ERS-1/2: $\lambda \approx 5.6$ cm

$R \approx 870$ km

$\theta \approx 23$ deg

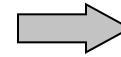

$$\frac{\partial \phi}{\partial z} \approx 2 \pi \cdot \frac{B_{\perp}}{(100 \text{ m})^2}$$

baseline	height for 1 phase cycle (2π)	
50 m	≈ 200 m	<i>“height of ambiguity”</i>
100 m	≈ 100 m	
200 m	≈ 50 m	

Is there a limit to the baseline?

\Rightarrow critical baseline,
see spectral shift!

Structure

- Interferometric phase error sources
- Coherence and phase errors
- Geometric accuracy
- Distributed scatterers (geometric decorrelation)
- Temporal decorrelation
- Atmospheric errors
- Persistent Scatterer Interferometry
- Bistatic systems (TanDEM-X)

Interferometry with Distributed Scatterers

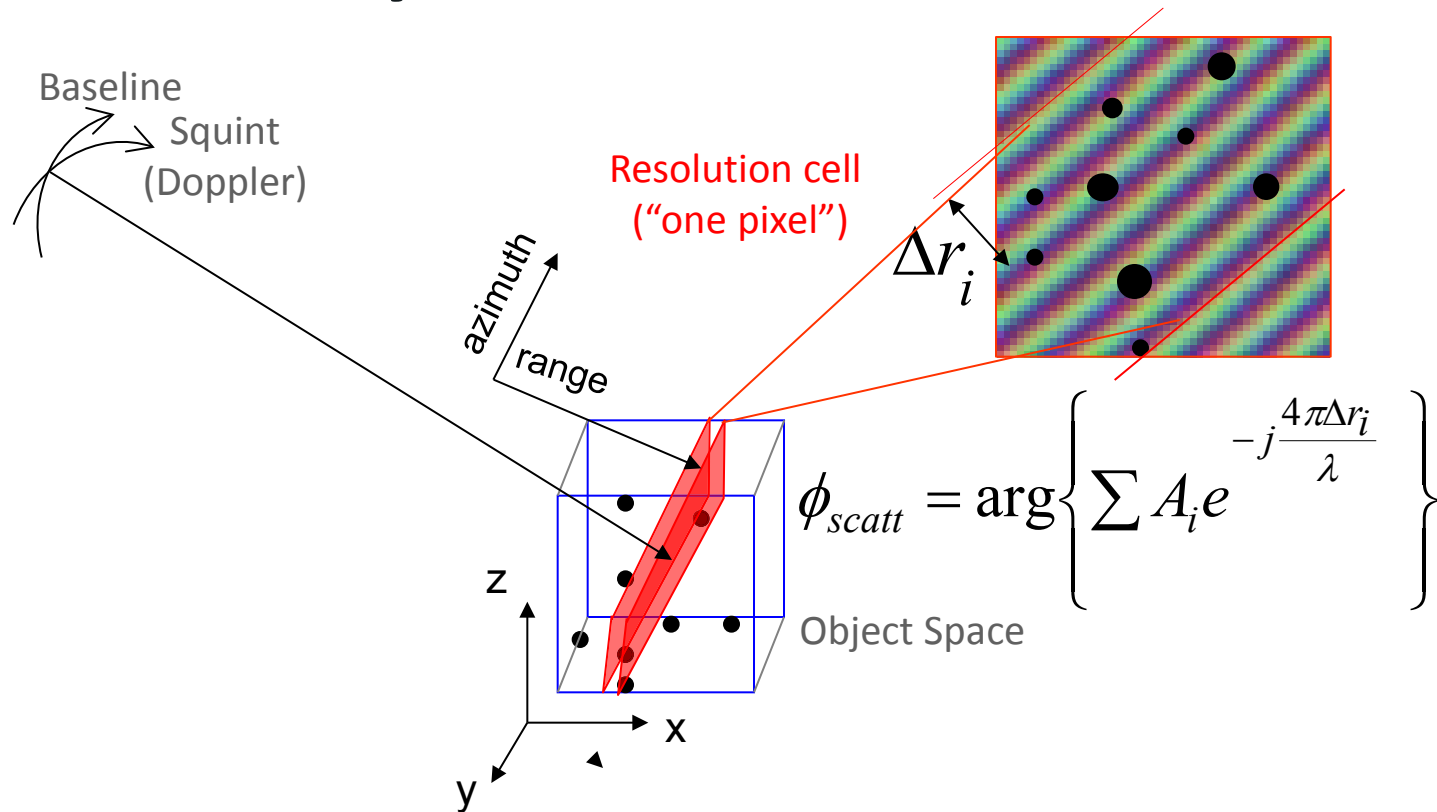

Random speckle phase : all acquisitions should contain same ensemble of scatterers in each resolution cell

- Repeat image acquisition from similar angle (→ maximum Baseline, maximum Doppler difference)
- Avoid temporal disordering of scatterers

3D Scattering: Volume Decorrelation

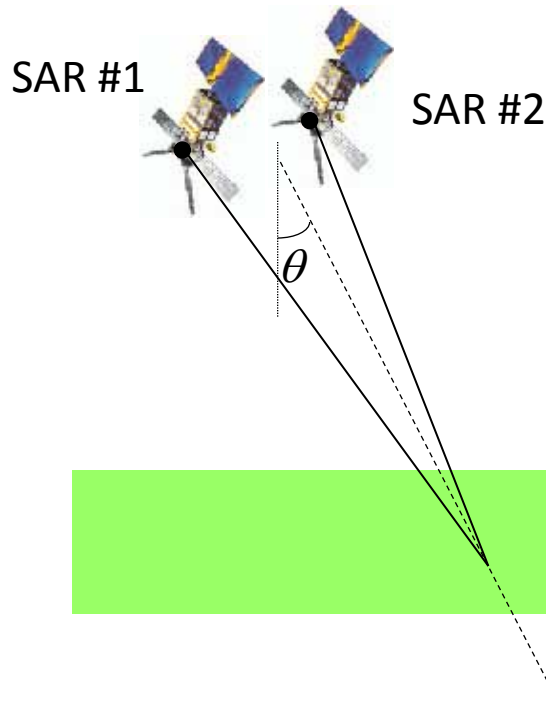

Volume decorrelation: $\gamma_{vol} = \text{sinc}(\Delta z / \Delta z_0)$

Critical thickness ($\gamma_{vol} = 0$): $\Delta z_0 = \frac{\lambda R_S \sin \theta}{2 B_{\perp}}$

Δz scattering layer (e.g. vegetation, canopy, ice, sand)

e.g.: ERS with $B_{\perp} = 200 \text{ m} \Rightarrow \Delta z_0 \approx 50 \text{ m}$

TerraSAR-X with $B_{\perp} = 300 \text{ m} \Rightarrow \Delta z_0 \approx 25 \text{ m}$

SRTM-X with $B_{\perp} = 30 \text{ m} \Rightarrow \Delta z_0 \approx 167 \text{ m}$

SRTM-C with $B_{\perp} = 30 \text{ m} \Rightarrow \Delta z_0 \approx 280 \text{ m}$

Fig.: © DLR

Flat Earth Fringe Frequency

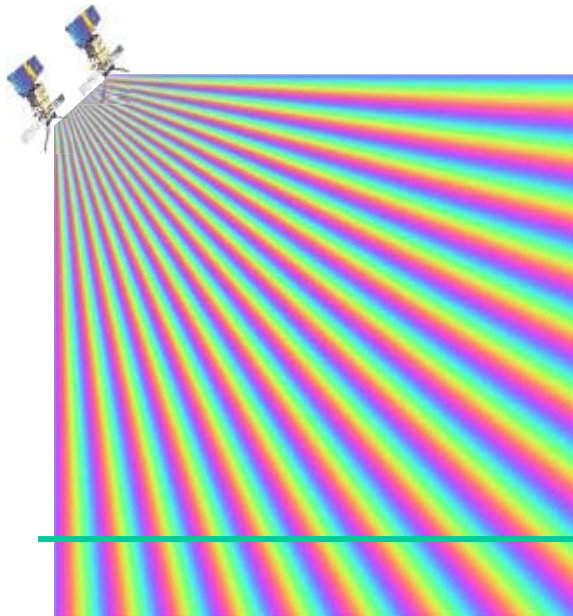

Frequency of flat earth fringes in radar slant range images? $\frac{\Delta\phi}{2\pi\Delta r} = ?$

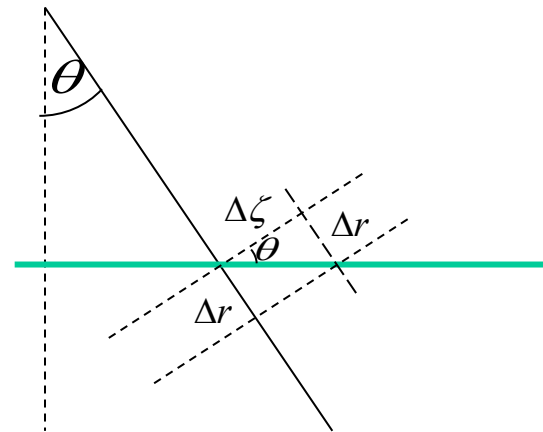

Range sampling interval: $\Delta r = \Delta\zeta \tan\theta$

$$\Delta\phi = 4\pi \frac{B_{\perp} \Delta\zeta}{\lambda R}$$

$$\rightarrow \frac{\Delta\phi}{2\pi\Delta r} = \frac{2}{\lambda} \frac{B_{\perp}}{R \tan\theta}$$

→ Flat earth fringes are usually removed in displayed interferograms

Fringe Frequency of Slopes

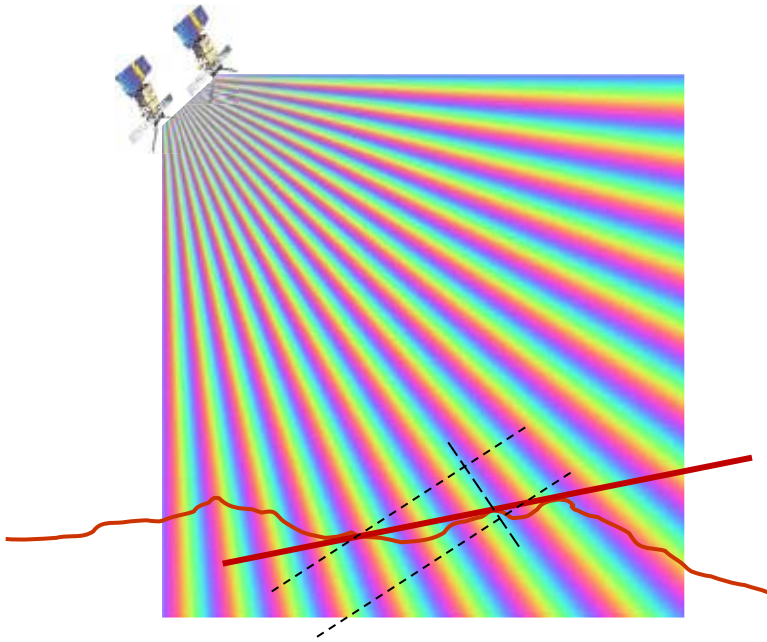

Frequency of flat **slope** fringes in radar slant range images?

→ Equivalent to change of incidence angle $\theta \rightarrow \theta - \alpha$

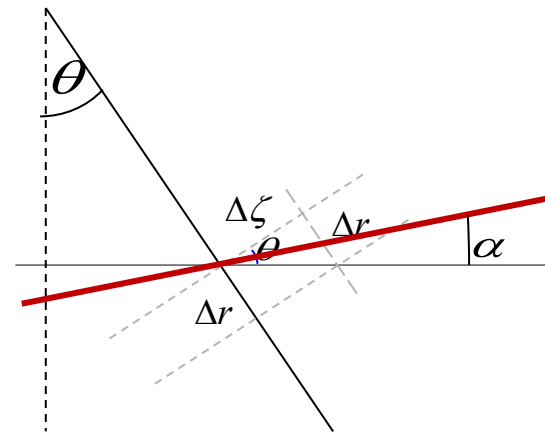

$$\rightarrow \frac{\Delta\phi}{2\pi\Delta r} = \frac{2}{\lambda} \frac{B_{\perp}}{R \tan(\theta - \alpha)}$$

Fig.: © DLR

!!! if $\theta \approx \alpha$

2D Scattering: Spectral Shift Decorrelation

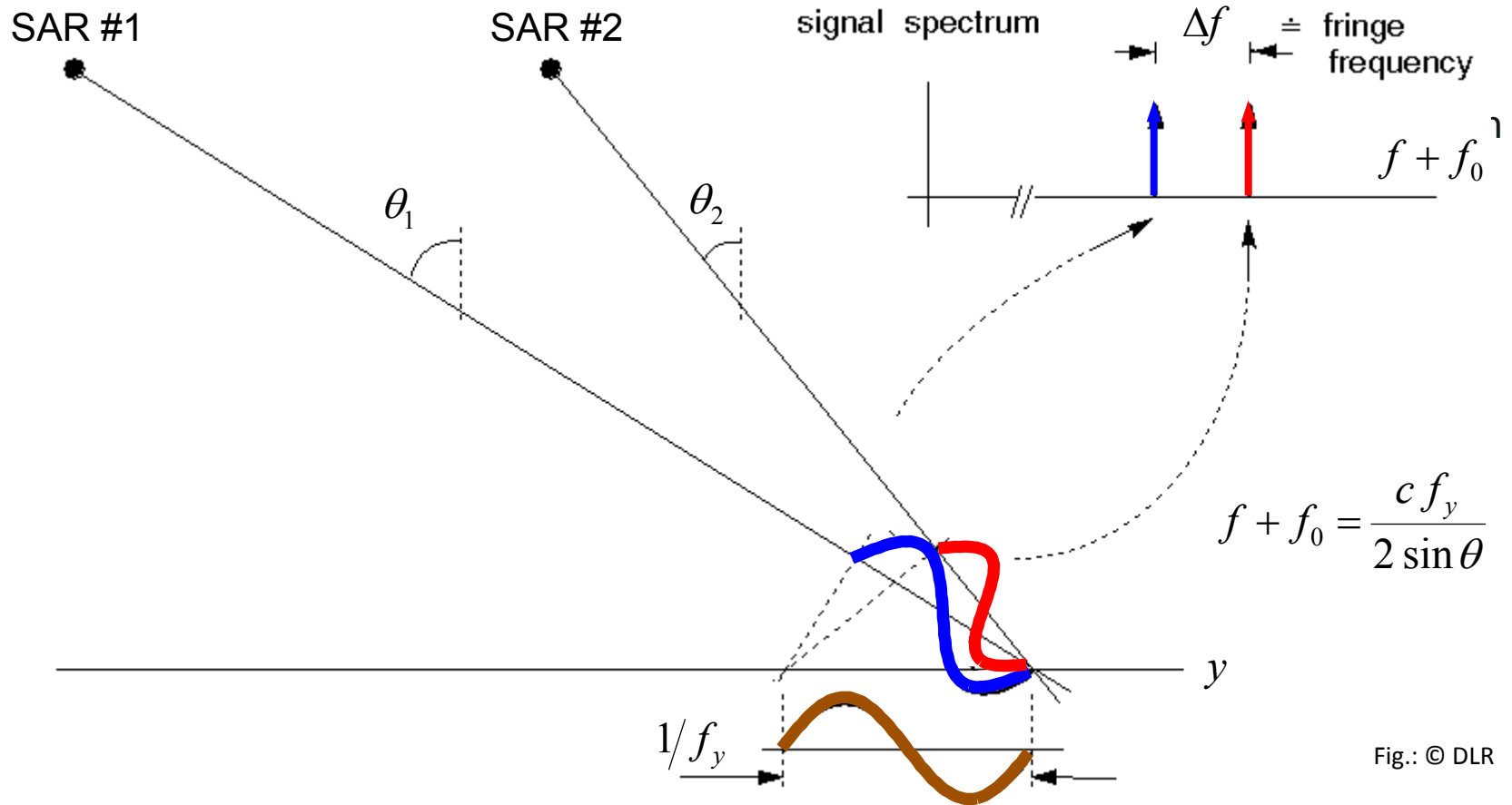

→ One ground frequency is projected to different radar frequency depending on incidence angle θ

Spatial Ground Reflectivity Spectrum vs. Signal Spectrum

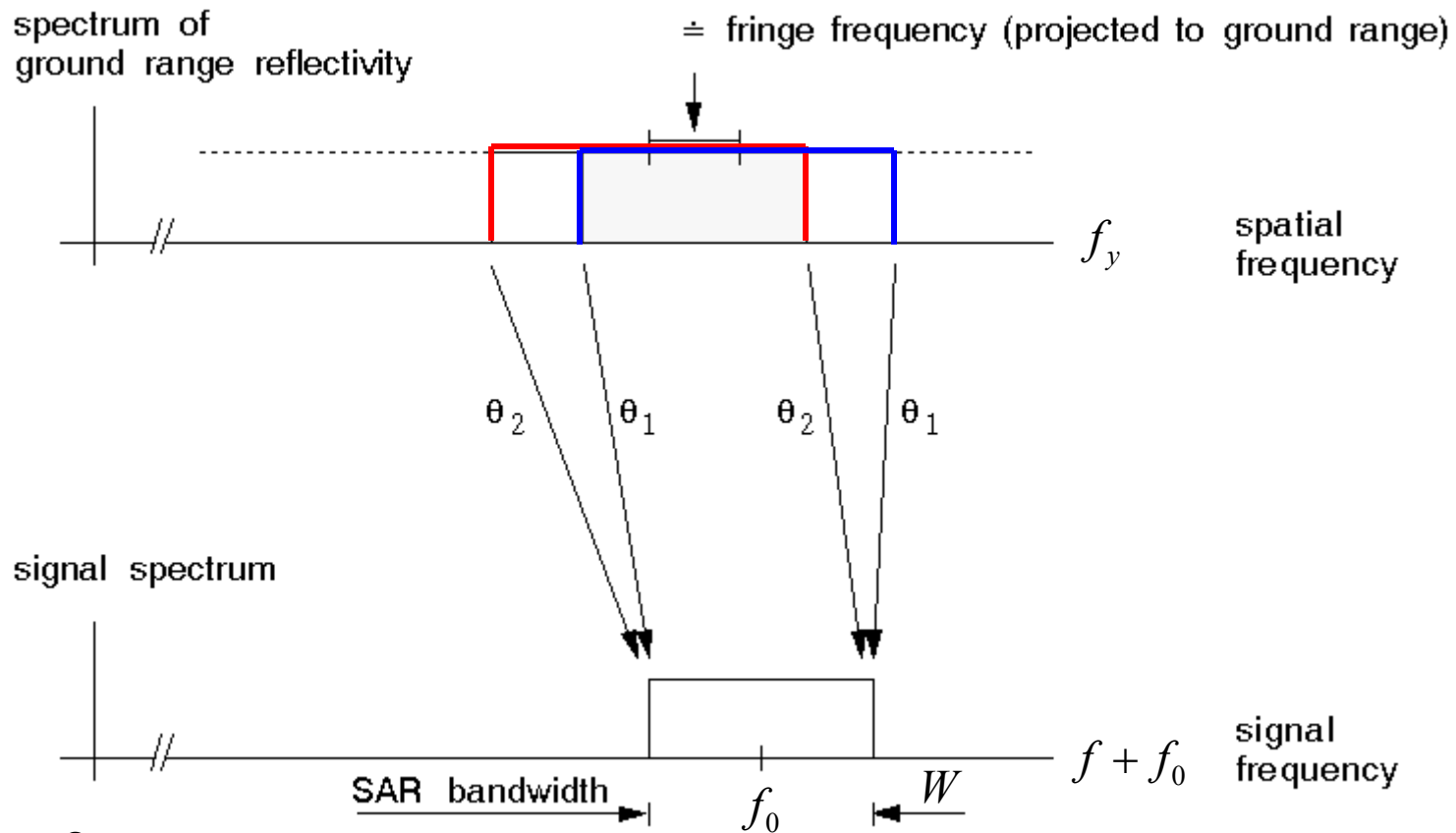
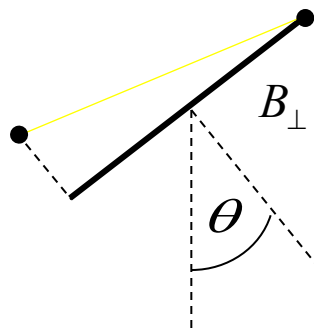

Fig.: © DLR

➤ Spectral shift filtering: cut off non-overlapping spectral bands

Local Range Fringe Frequency and Flat Earth Phase



$$\text{fringe frequency in range: } f_{\phi} = \frac{1}{2\pi} \frac{\partial \phi}{\partial R} = \frac{2B_{\perp}}{\lambda R \tan(\theta - \alpha)}$$

$$\text{flat Earth fringe frequency: } \frac{2B_{\perp}}{\lambda R \tan \theta}$$

example: ERS, baseline $B_{\perp} = 200 \text{ m}$

\Rightarrow 1 cycle per 50 m or 6 range samples

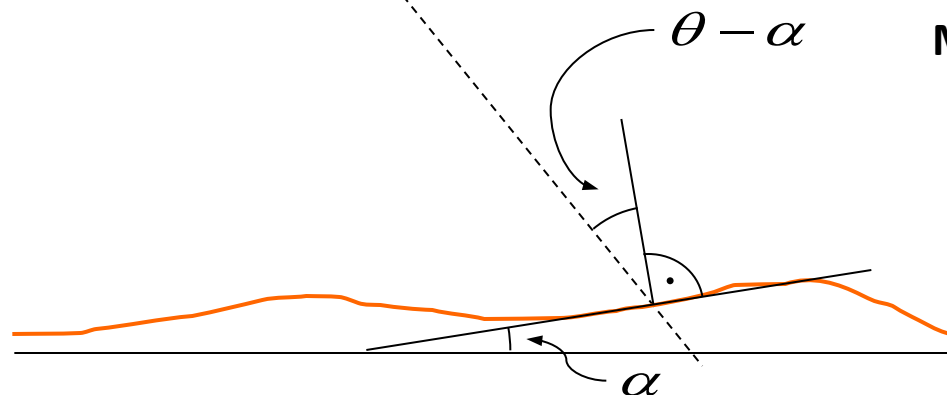

**Maximum (=critical) baseline:
1 cycle per resolution cell**

Spectral Shift and Critical Baseline

spectral shift = fringe frequency: $\Delta f(\alpha) = -\frac{c B_{\perp, effective}}{R \lambda \tan(\theta - \alpha)}$ α : terrain slope

$$\text{decorrelation: } \gamma_B = 1 - \left| \frac{\Delta f}{W} \right|$$

critical (= maximum) baseline ($\Delta f(\alpha) = W$): $B_{\perp, crit} = \left| \frac{W R \lambda \tan(\theta - \alpha)}{c} \right|$

W : range signal bandwidth (e.g. 15.5 MHz for ERS, 150 MHz for TerraSAR-X)

interferometric range resolution: $\rho_y(\alpha) = \frac{c}{2(W - \Delta f(\alpha))}$

Spectral Shift for ERS

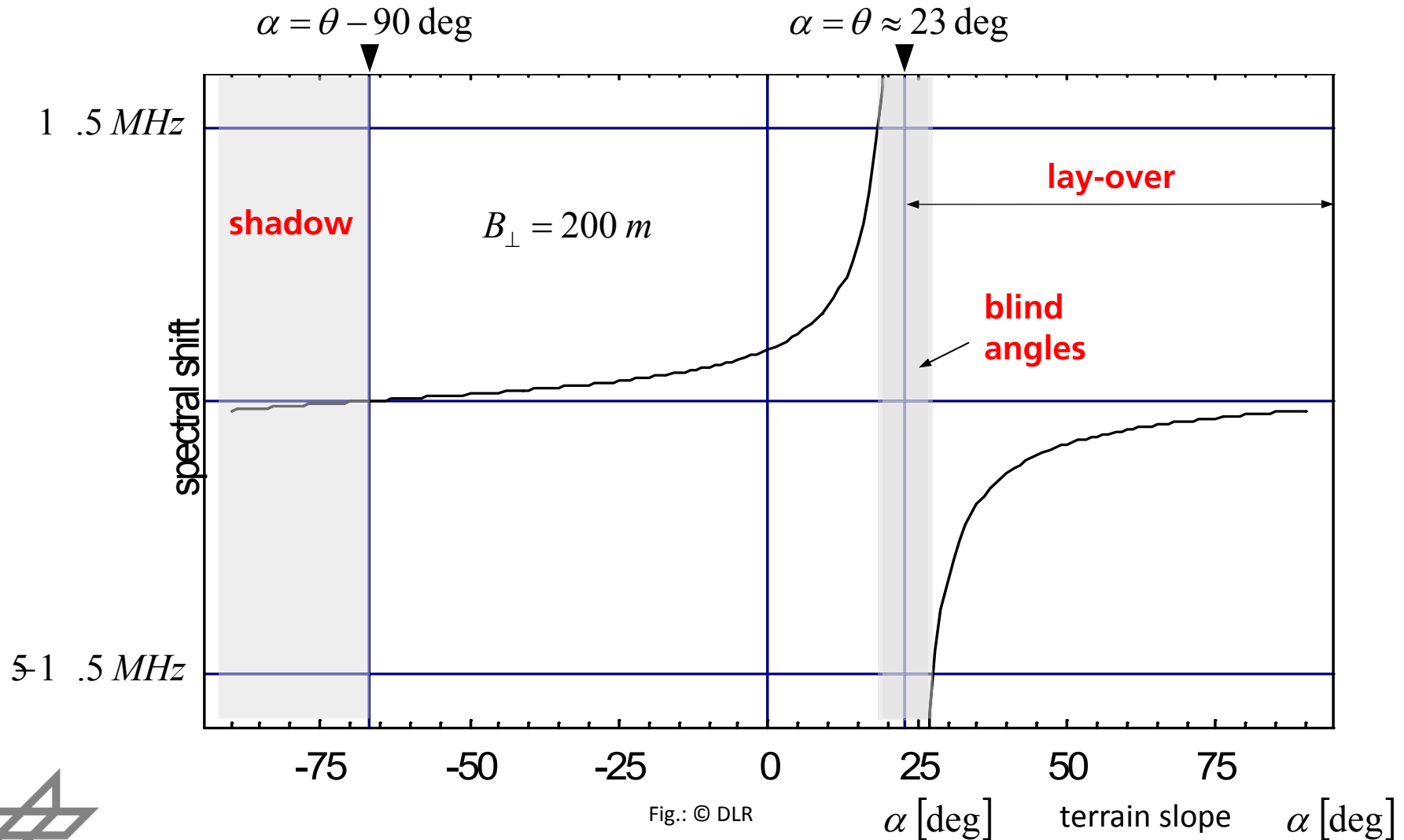

Fig.: © DLR

Structure

- Interferometric phase error sources
- Coherence and phase errors
- Geometric accuracy
- Distributed scatterers (geometric decorrelation)
- Temporal decorrelation
- Atmospheric errors
- Persistent Scatterer Interferometry
- Bistatic systems (TanDEM-X)

Temporal Decorrelation

Important: main limitation in repeat-pass interferometry

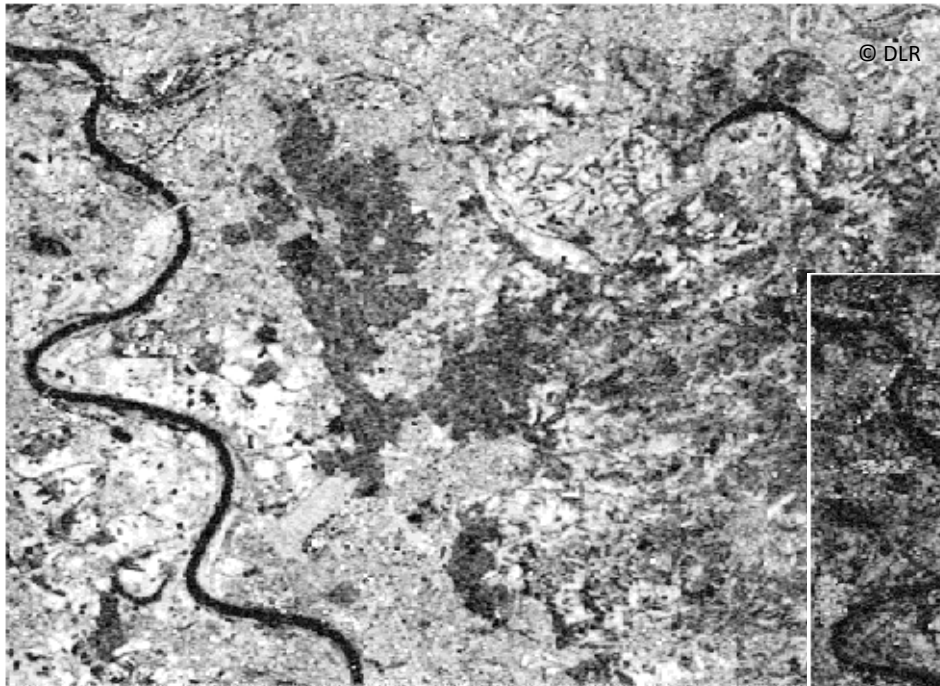

short term interferogram (15.01 – 21.01)

long term interferogram (15.01 – 20.02)

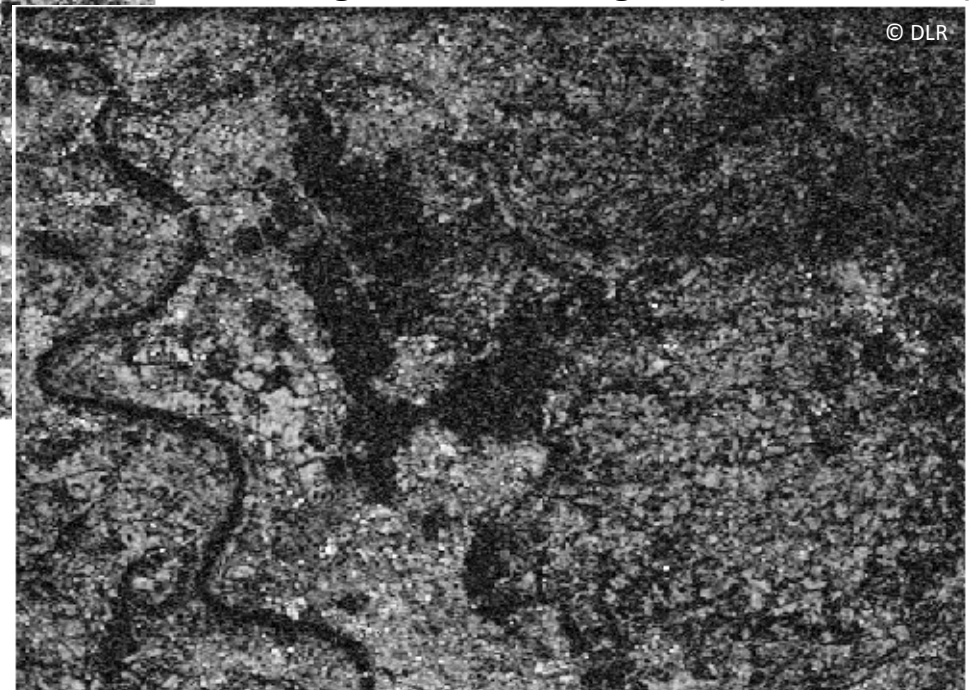

Temporal Decorrelation



Simple Model:
$$\gamma_{temp} = e^{-\frac{1}{2} \left(\frac{4\pi}{\lambda} \right)^2 \left(\sigma_y^2 \sin^2 \theta + \sigma_z^2 \cos^2 \theta \right)}$$
 (Zebker, 1992)

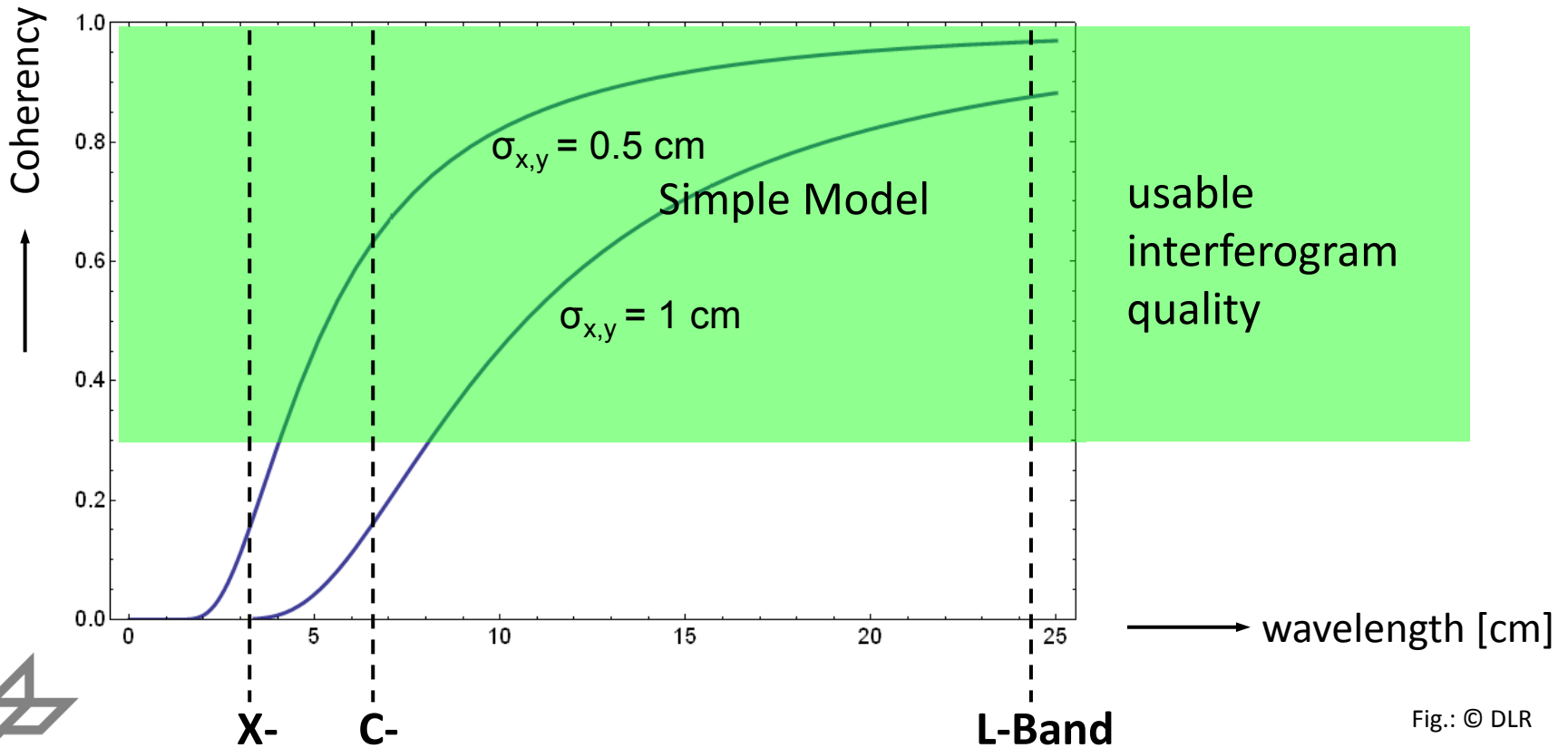
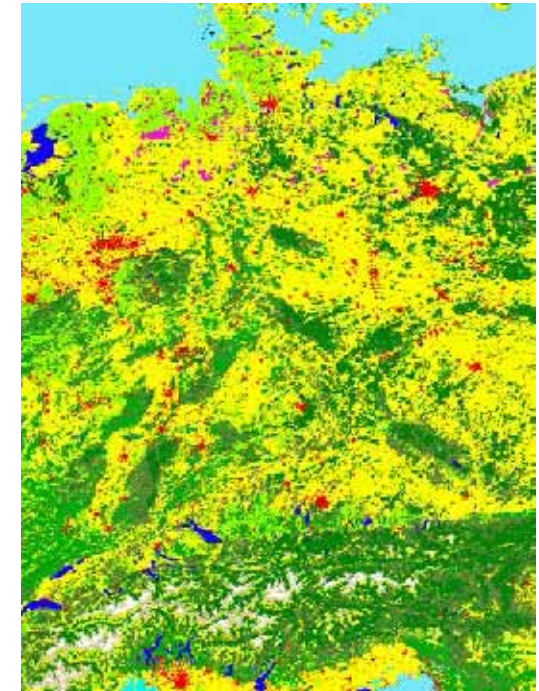

Fig.: © DLR

ERS-Tandem Coherence Mosaic for Germany



**PELCOM Land Cover
Database**

→ Forests lead to
decorrelation!

Coherence

0.0 0.2 0.4 0.6 0.8 1.0

Mexico City – Coherence

12 Cycles

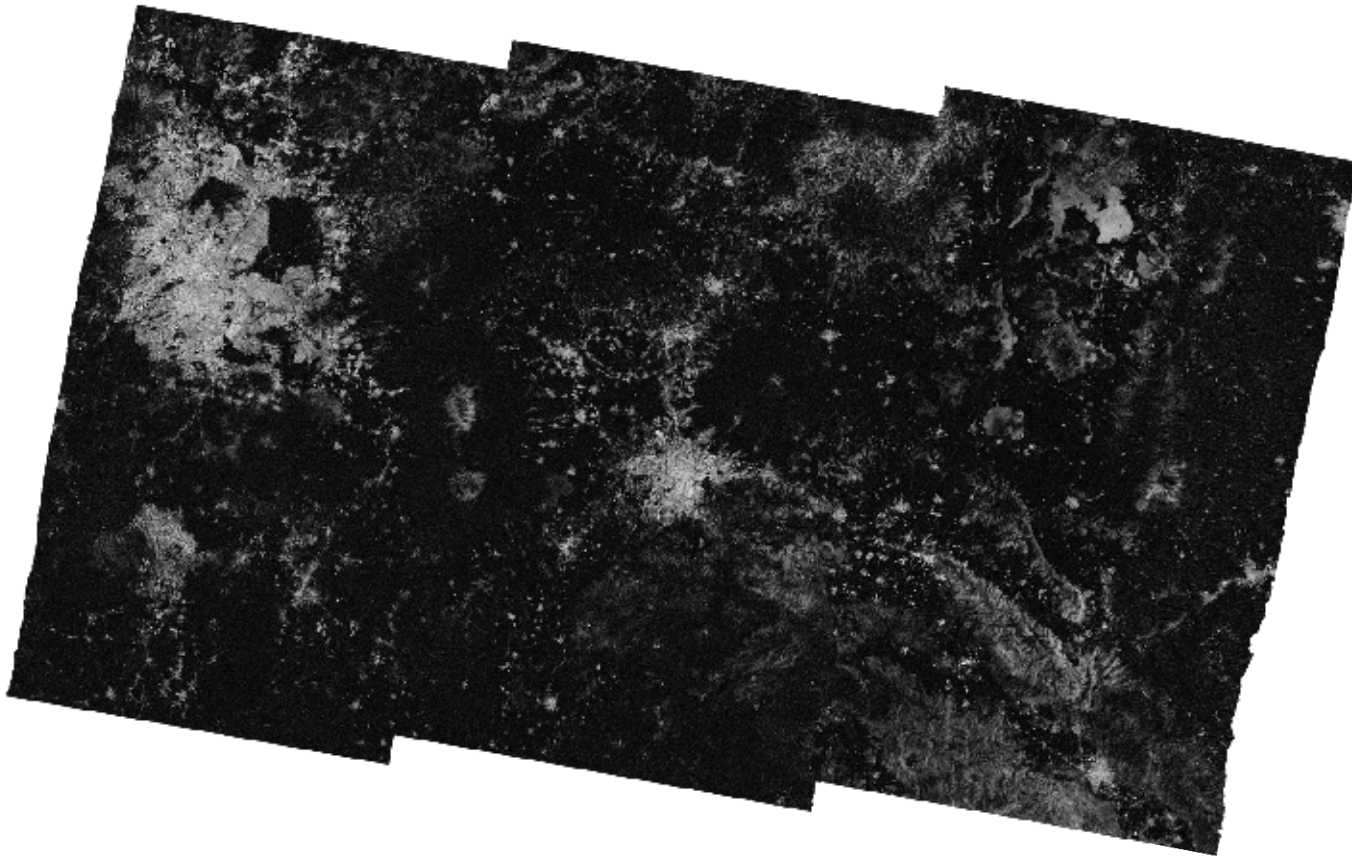

Contains modified Copernicus Sentinel data 2014-2015 / DLR

Structure

- Interferometric phase error sources
- Coherence and phase errors
- Geometric accuracy
- Distributed scatterers (geometric decorrelation)
- Temporal decorrelation
- **Atmospheric errors**
- Persistent Scatterer Interferometry
- Bistatic systems (TanDEM-X)

SAR Signal Propagation Through Atmosphere

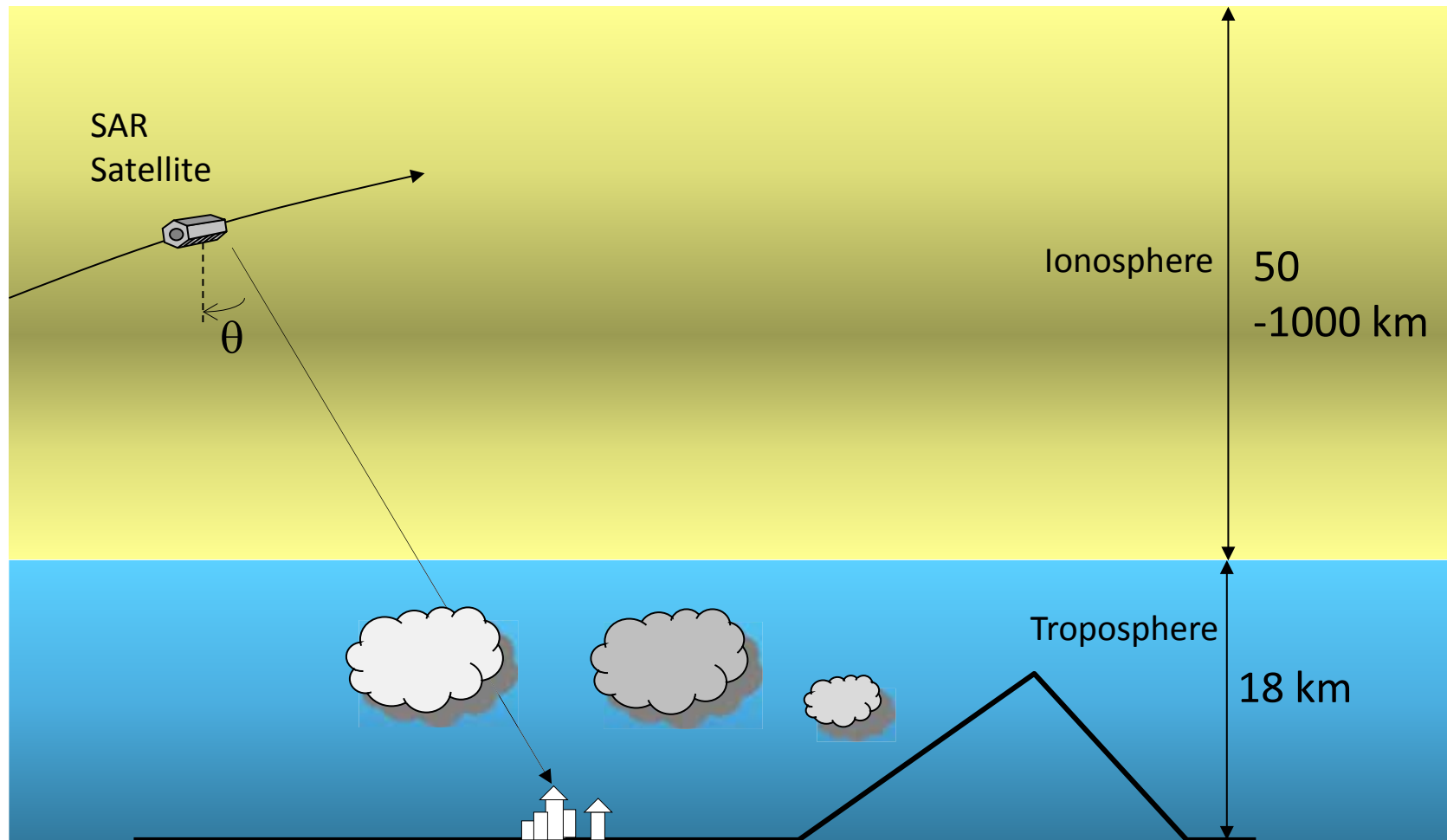

Fig.: © DLR

SAR Path Length Extension in Atmosphere

$$L = 10^{-6} \int_{r_{ground}}^{r_{satellite}} N dr$$

$$= 10^{-6} \int_{r_{ground}}^{r_{satellite}} k_1 \frac{P_d}{T} + k_2 \frac{e}{T} + k_3 \frac{e}{T^2} + 1.45 W_{cl} + 4.028 \frac{n^2}{f^2} dr$$

k_1, k_2, k_3 : constants

T : temperature

e : partial pressure of water vapour (fast spatial variation)

P_d : pressure of dry air

W_{cl} : liquid water (droplets)

n : electron density in atmosphere

f : frequency of radar system

Propagation Delays - Ionosphere

➤ Ionosphere is dispersive

- dependence on $1/f^2$:

$$d_{phase} = -K \text{TEC} / f^2$$

($K=40.28 \text{ m}^3\text{s}^{-2}$)

- Signal (group) delay due to Total Electron Content (TEC) causes *slant range error* at L-band ($f=1.25\text{GHz}$) of up to 60 m at 45 deg incidence angle

- Phase advance due to TEC is $1.3 \times 10^9 \text{ TEC} / f^2$ [cycles]
(> 100 cycles for 80 TECU, L-Band)

- Spatially slowly varying in one image

- Minor impact on C and X band data in lower geographic latitudes

- Can be compensated by multi-frequency processing (→GNSS)

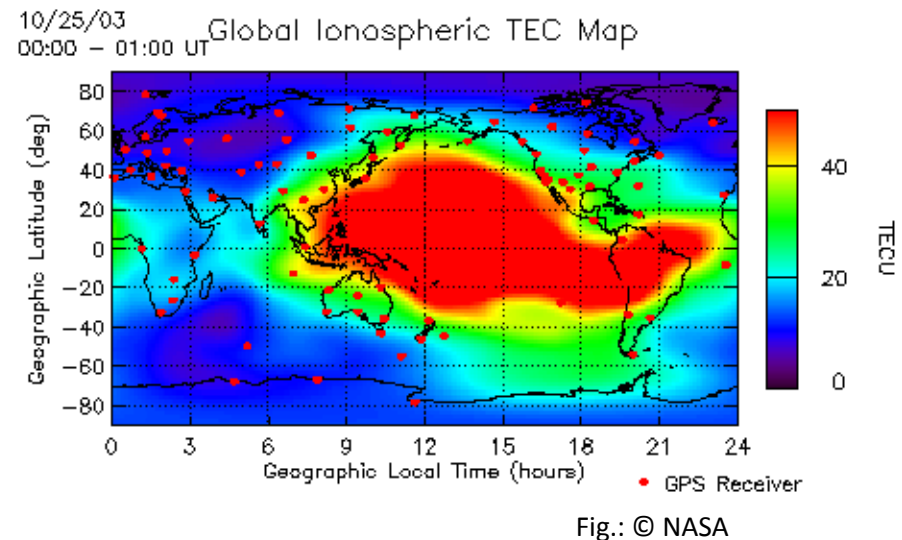

Phase Distortions Caused by Atmospheric Water Vapour

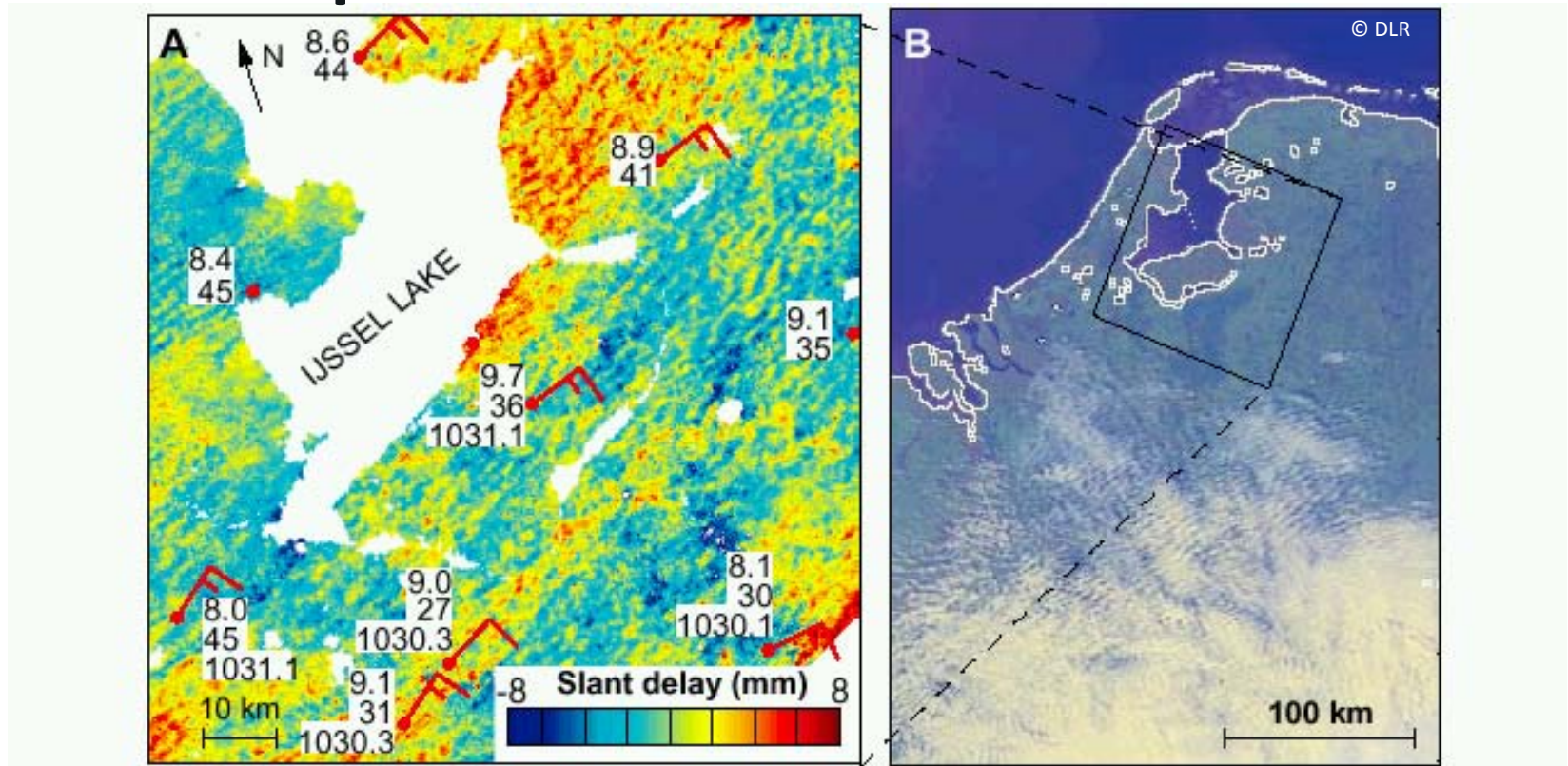

Fig. 4. (A) SAR interferogram of 4 and 5 April 1996, 10:35 UTC, showing “water vapor streets,” caused by horizontal convective rolls. Surface station observations of 4 April, 11:00 UTC, are superposed as in Fig. 3B. (B) Radiometer (NOAA-AVHRR, channels 1, 2, and 4) color composite image acquired at 4 April 1996, 12:01 UTC.

Hanssen et al., 1999

Propagation Delays - Troposphere

- Large, spatially increasing errors
- Frequency independent, same range error in L, C and X band
 - Can **not** be compensated by multi-frequency processing

$$\sigma_{\Delta r}^2 = E[(\Delta r(x) - \Delta r(x + d))^2]$$

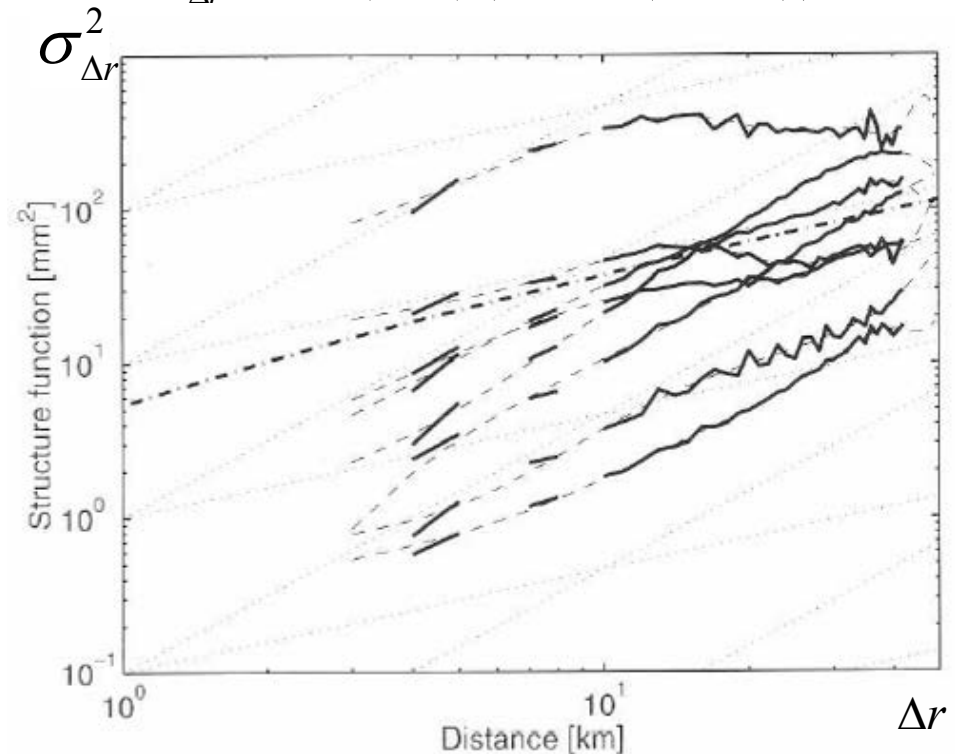

„Comparison of empirical structure functions (bold lines) of the tropospheric signal derived from ERS data with the theoretical model (dashed lines). Each line corresponds to a separate interferogram of the same area. Note that more severe weather conditions increase the power of the signal, but do not affect the slope of the structure function.“ (Hanssen, 2001)

Fig. 29: © DLR

Structure

- Interferometric phase error sources
- Coherence and phase errors
- Geometric accuracy
- Distributed scatterers (geometric decorrelation)
- Temporal decorrelation
- Atmospheric errors
- **Persistent Scatterer Interferometry**
- Bistatic systems (TanDEM-X)

Short Summary: InSAR Error Sources

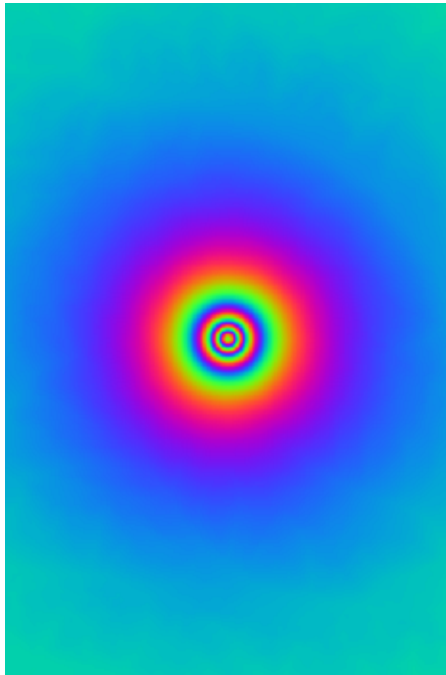

1. Phase ambiguities

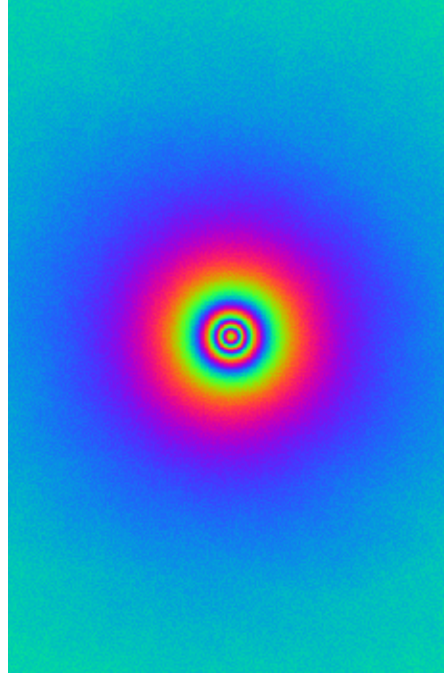

2. Decorrelation

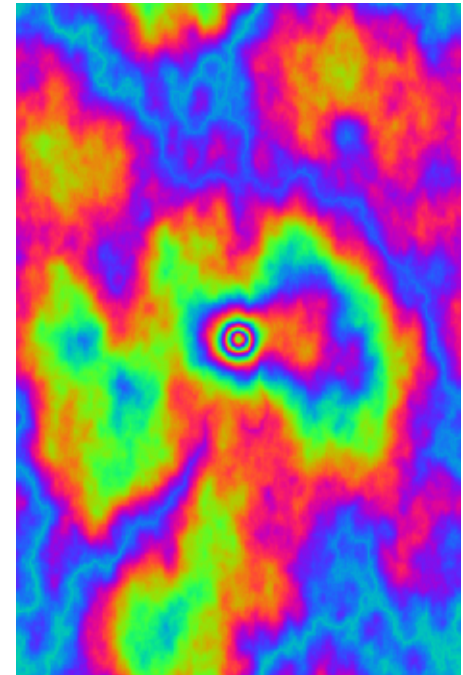

3. Propagation errors

→ Time series analysis and motion models required: **Persistent Scatterer Interferometry**

Persistent Scatterer Interferometry (PSI)

- Acquisition of stack of images
- Stacking (coregistration)
- Selection of points with stable (temporal) phase (very small percentage)
- Connection of points with short arcs network
- Parameter estimation of temporal phase model (linear, periodic ...) on each arc
- 2D network integration of model parameters including removal of APS (Atmospheric Phase Screen)

Persistent Scatterer Interferometry (PSI)

1. Acquisition

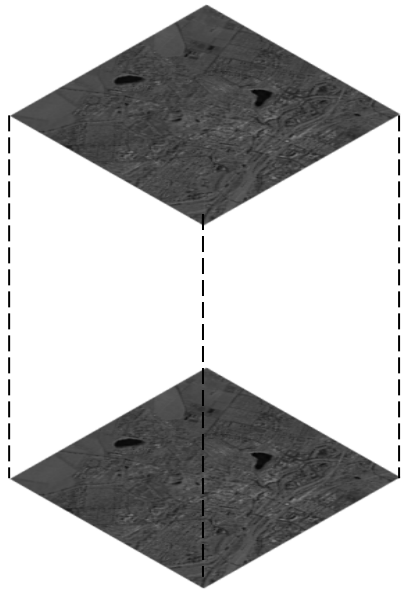

2. Stacking

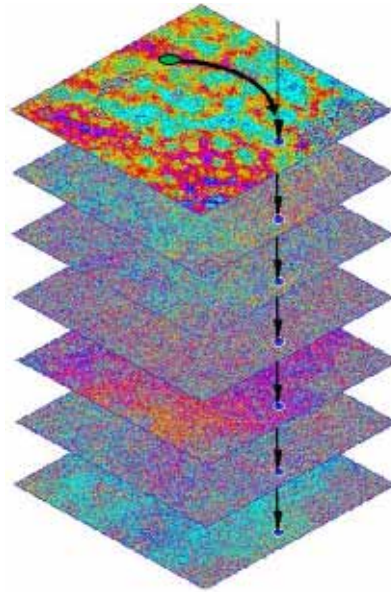

3. PS Detection

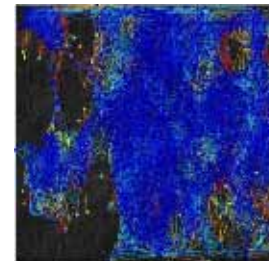

5. Estimation (and APS removal)



Fig.: © DLR

Point Scatterers

- Points with long-term coherence / correlation
- Stable scatterer phase over time

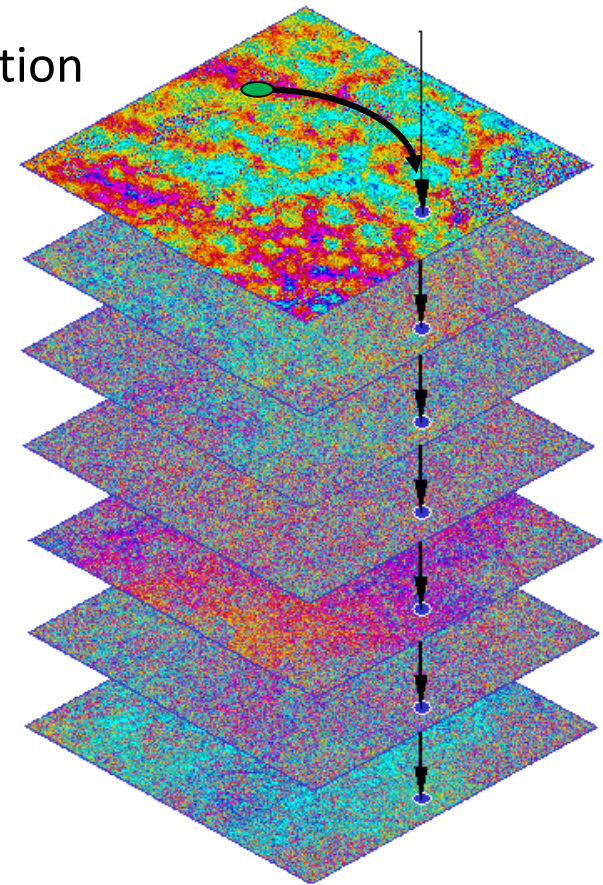
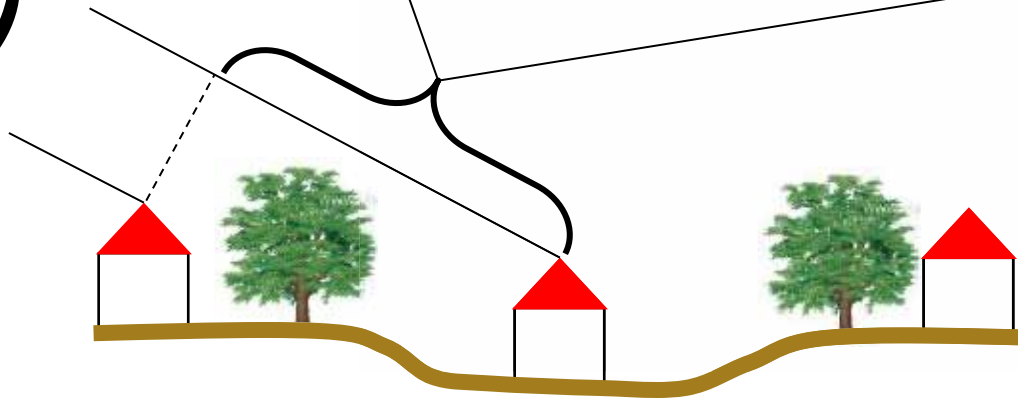
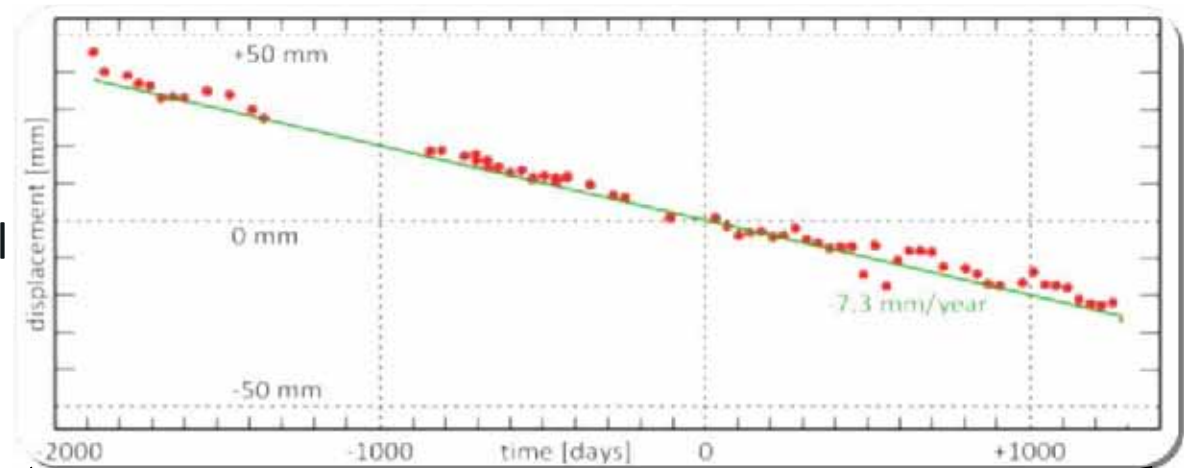

Fig.: © DLR

PSI - Precision

Temporal Coherence

How well PS phase fits model



- Stack size
- Temporal sampling
- Baseline sampling
- PS type (urban/rural)
- Master selection
- Deformation type & speed

Fig.: © DLR

PSI with ERS-1/ERS-2: Las Vegas

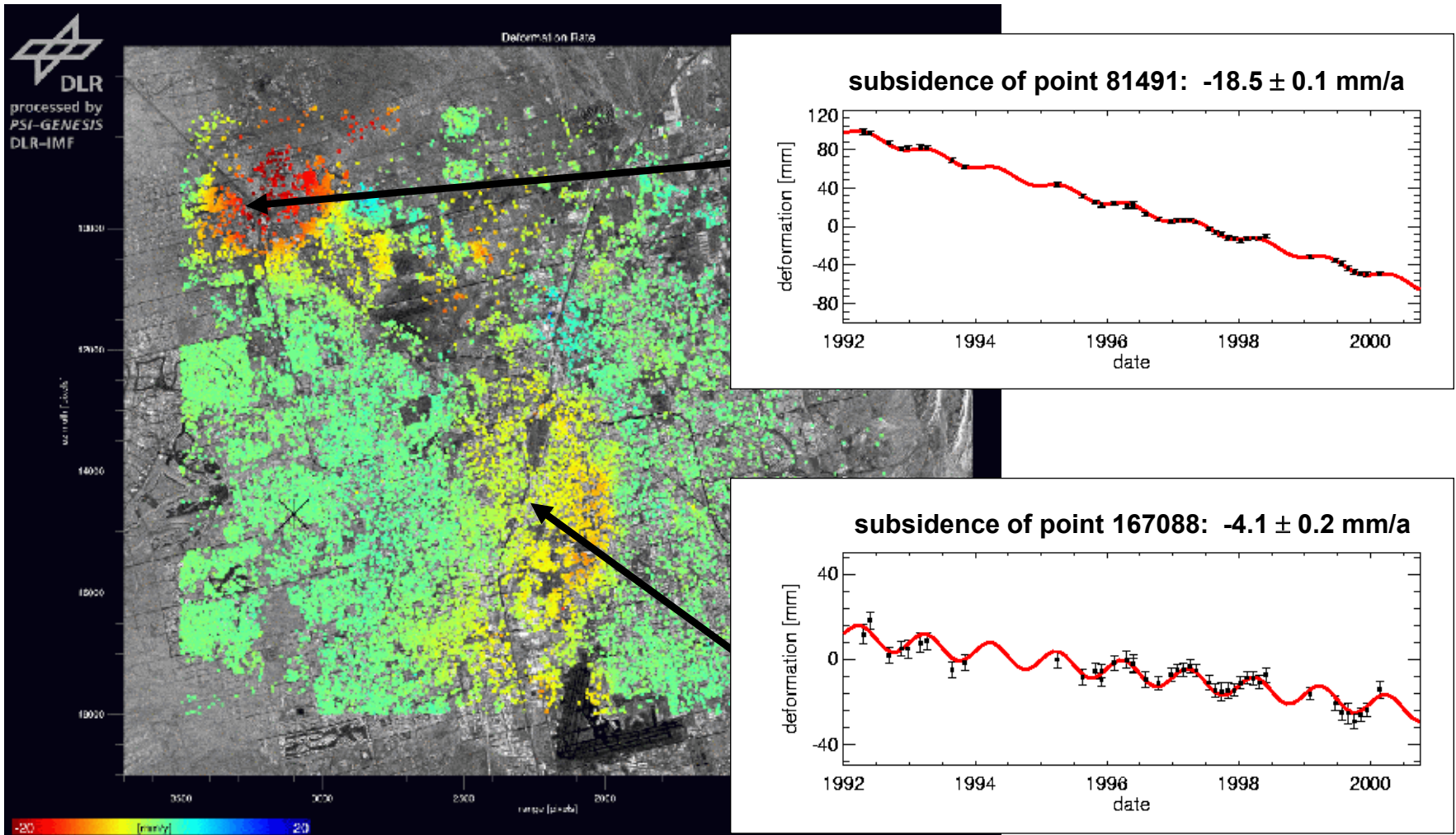
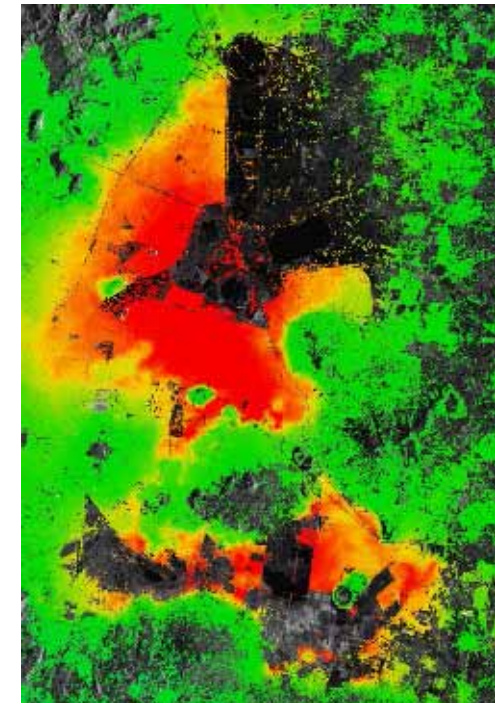
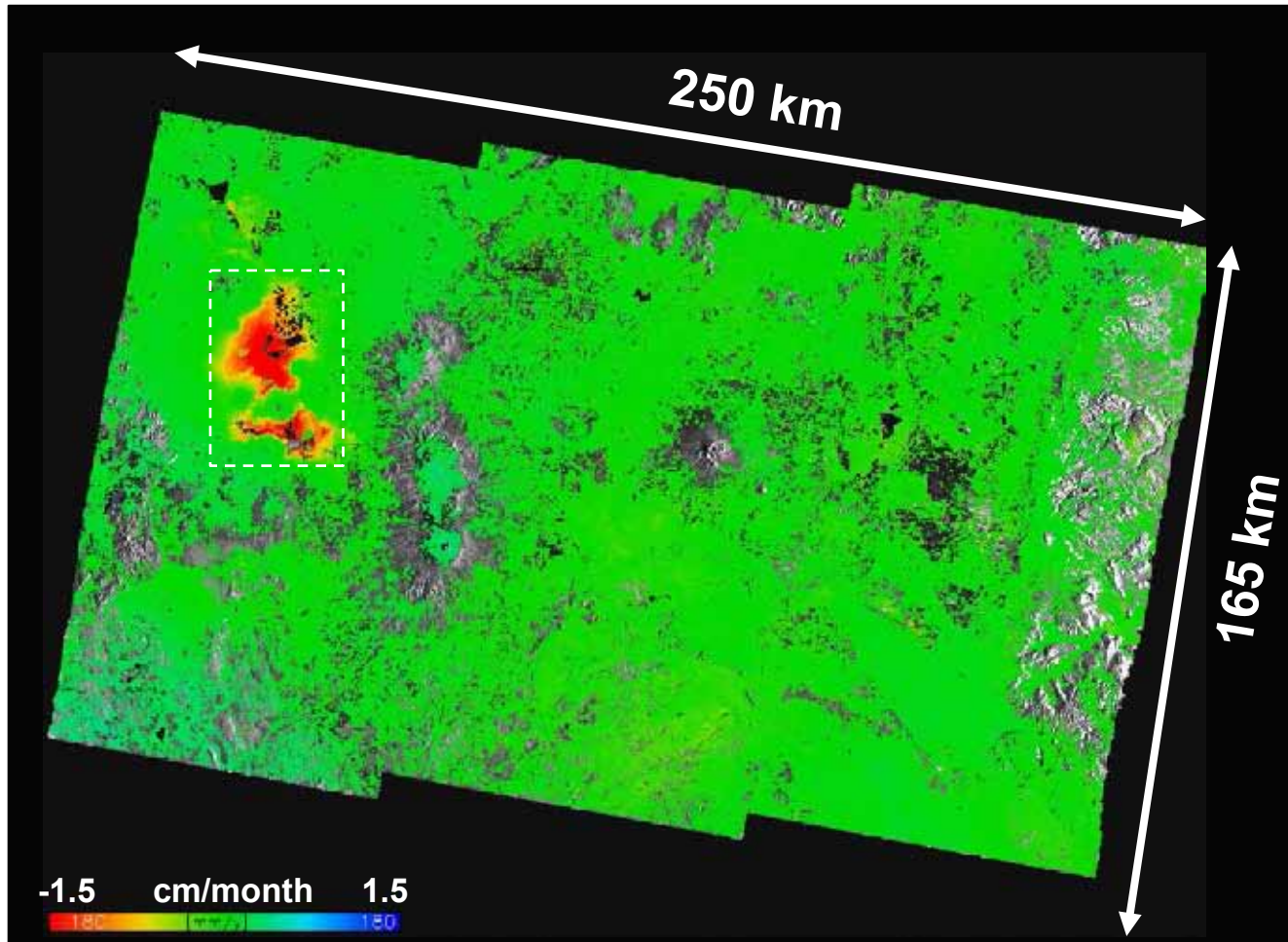

Fig.: © DLR

Sentinel-1 Wide Area PSI – Mexico



21 IW SLCs, VV, Descending

Time span: 2014-10-03 -
2015-06-24

Linear Deformation

Contains modified Copernicus Sentinel data 2014-2015 / DLR

Main Station in Berlin



Measurement of thermal dilation and 3D shape with TerraSAR-X PSI ...

Structural Thermal Dilation Measured With Multi Angle PSI



Ascending

Descending

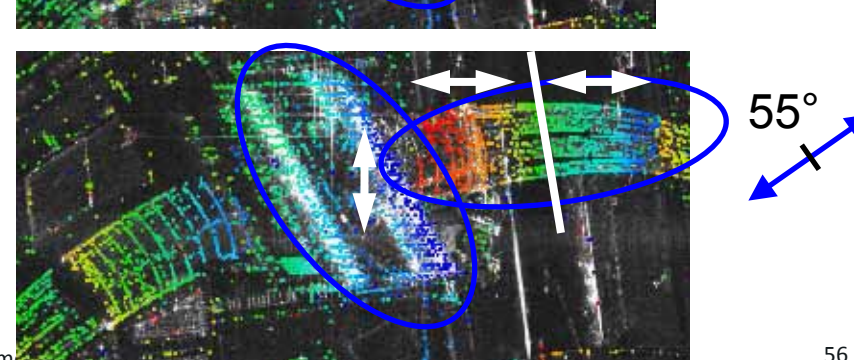
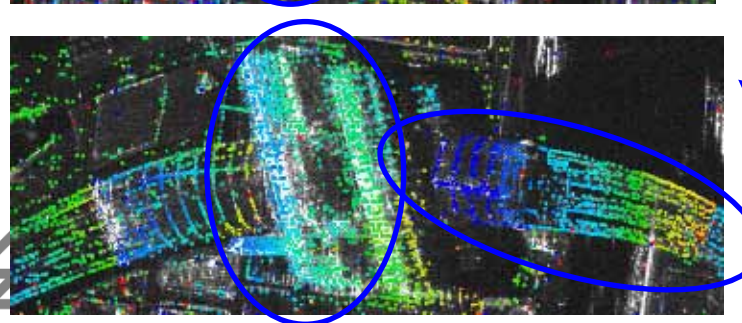
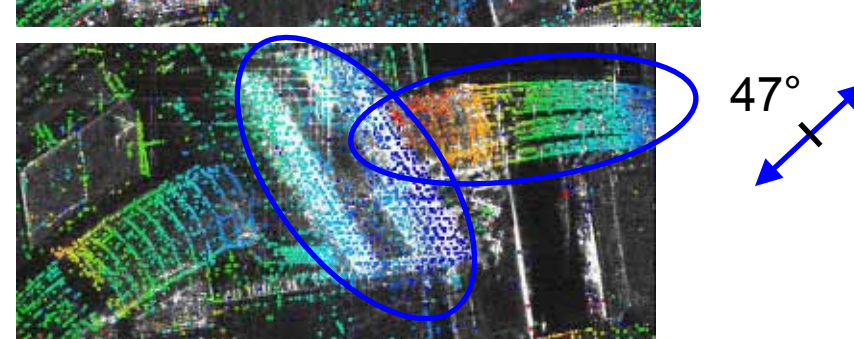
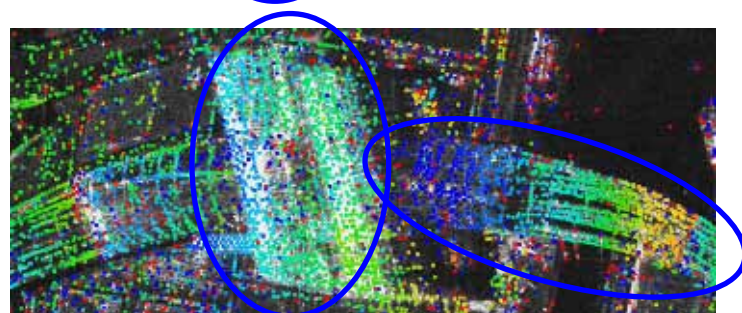
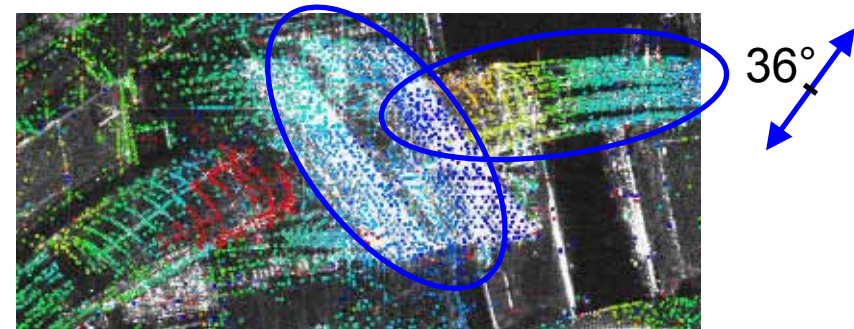
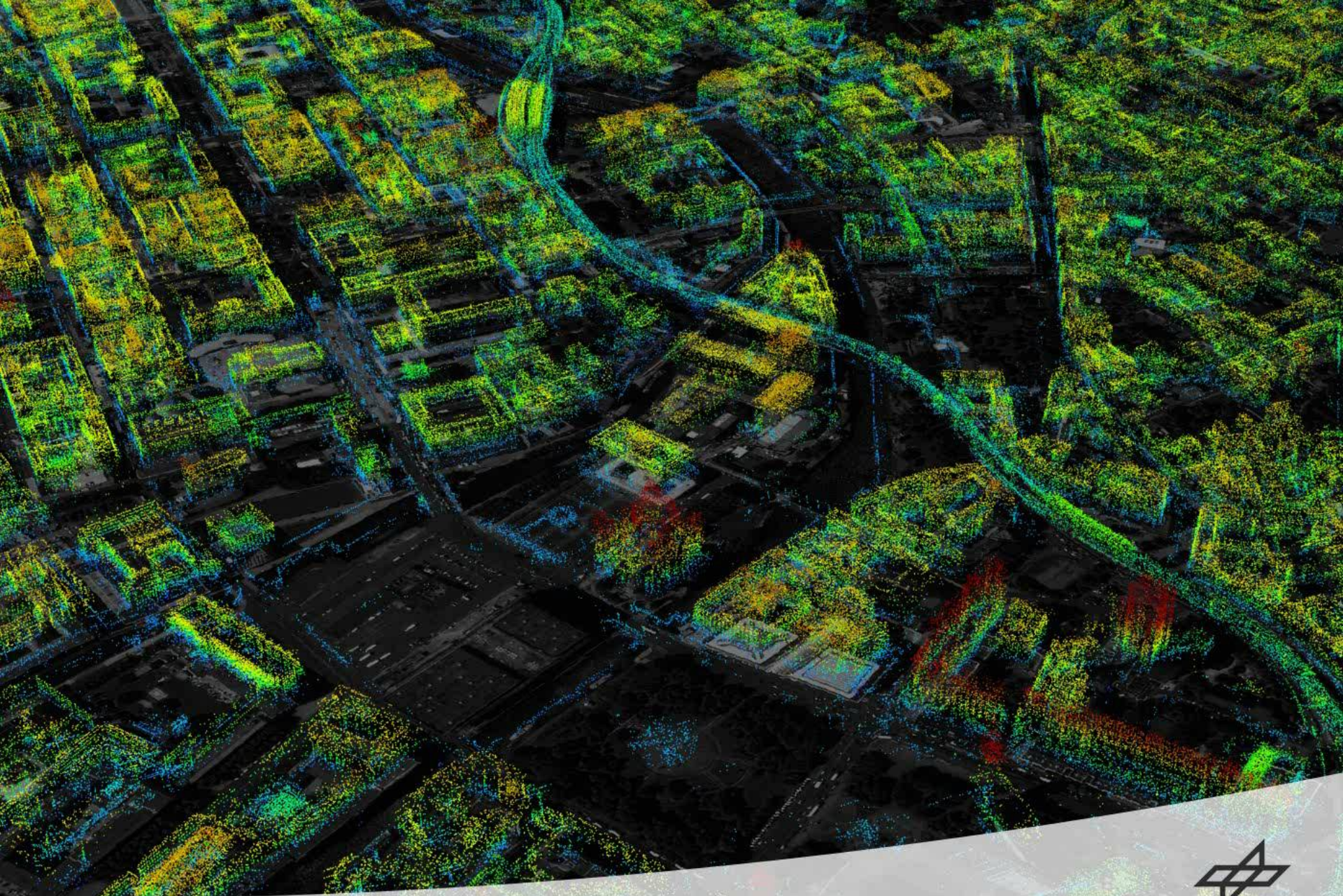
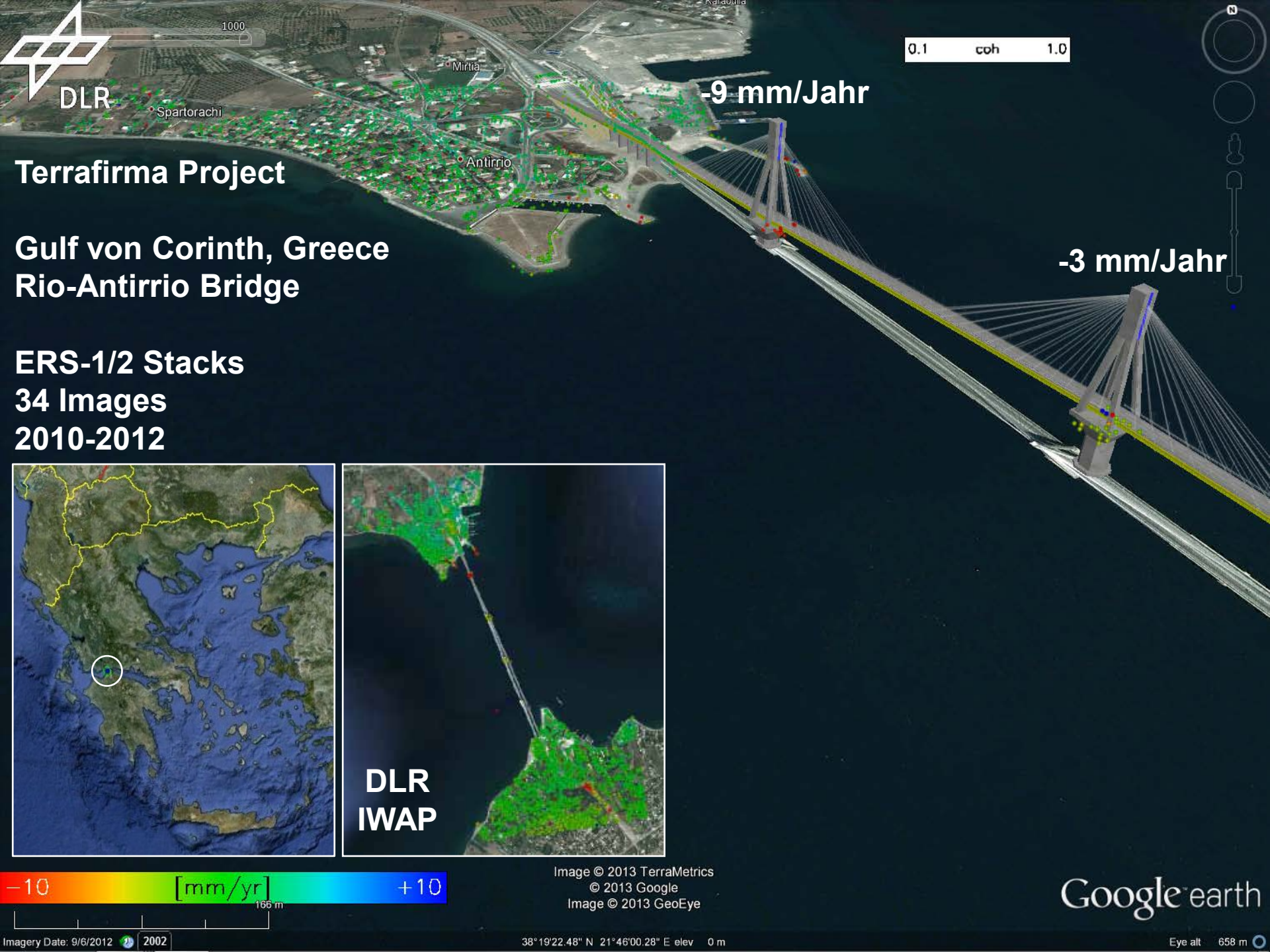

Fig.: © DLR



PS-CITY





DLR

Terrafirma Project

Gulf von Corinth, Greece Rio-Antirrio Bridge

ERS-1/2 Stacks
34 Images
2010-2012

0.1 coh 1.0

-9 mm/Jahr

-3 mm/Jahr



DLR
IWAP

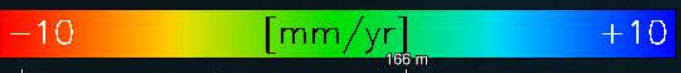

Image © 2013 TerraMetrics
© 2013 Google
Image © 2013 GeoEye

Google earth

Imagery Date: 9/6/2012 2002

38°19'22.48" N 21°46'00.28" E elev 0 m

Eye alt 658 m

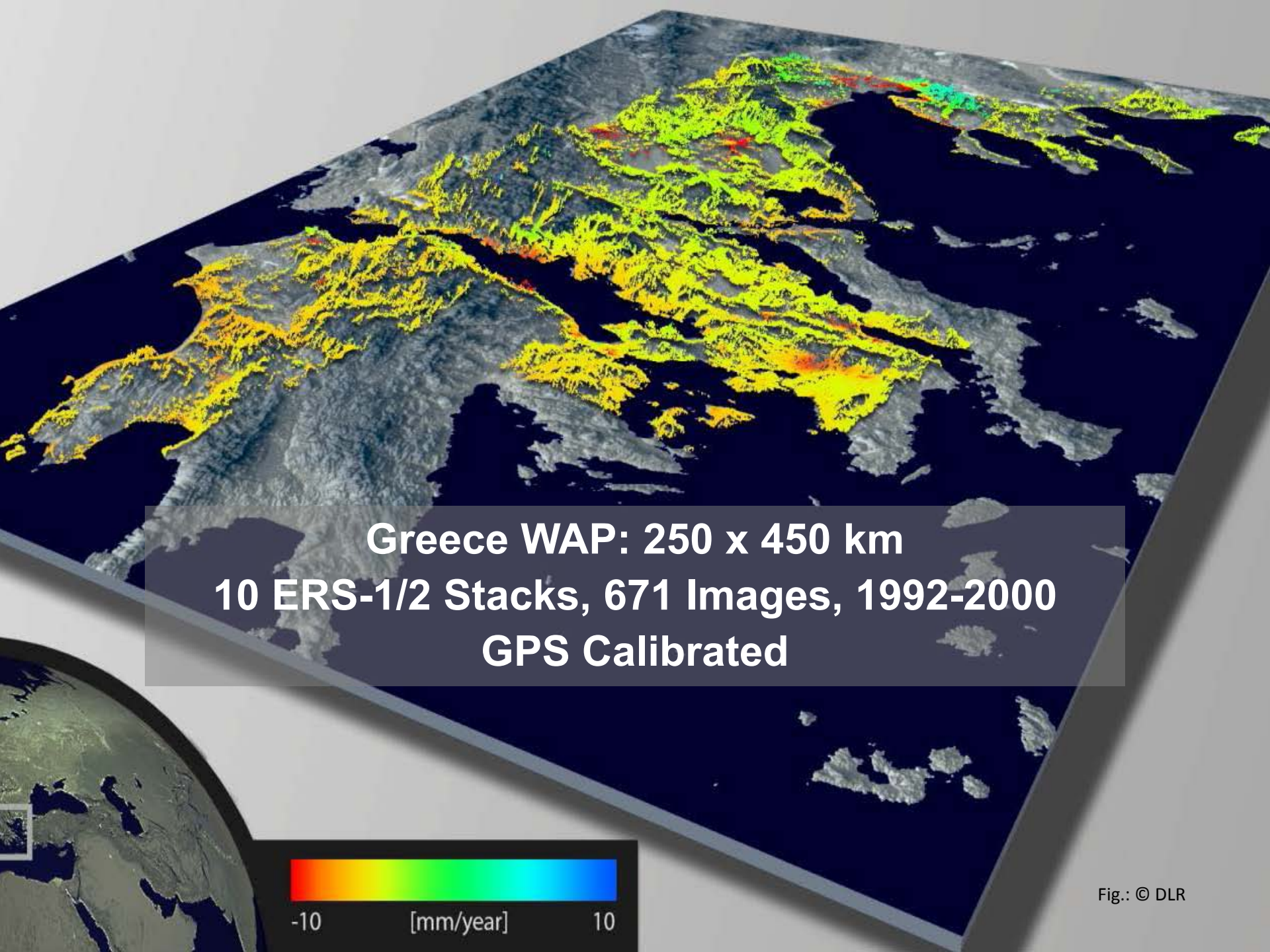

Greece WAP: 250 x 450 km
10 ERS-1/2 Stacks, 671 Images, 1992-2000
GPS Calibrated

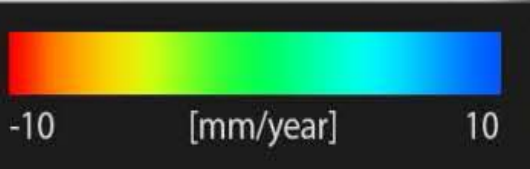

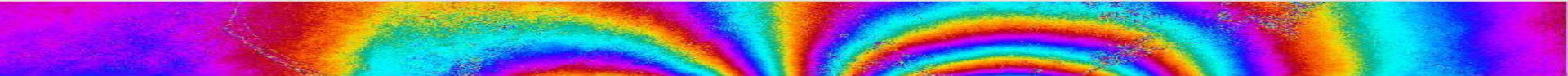

SAR Tomography

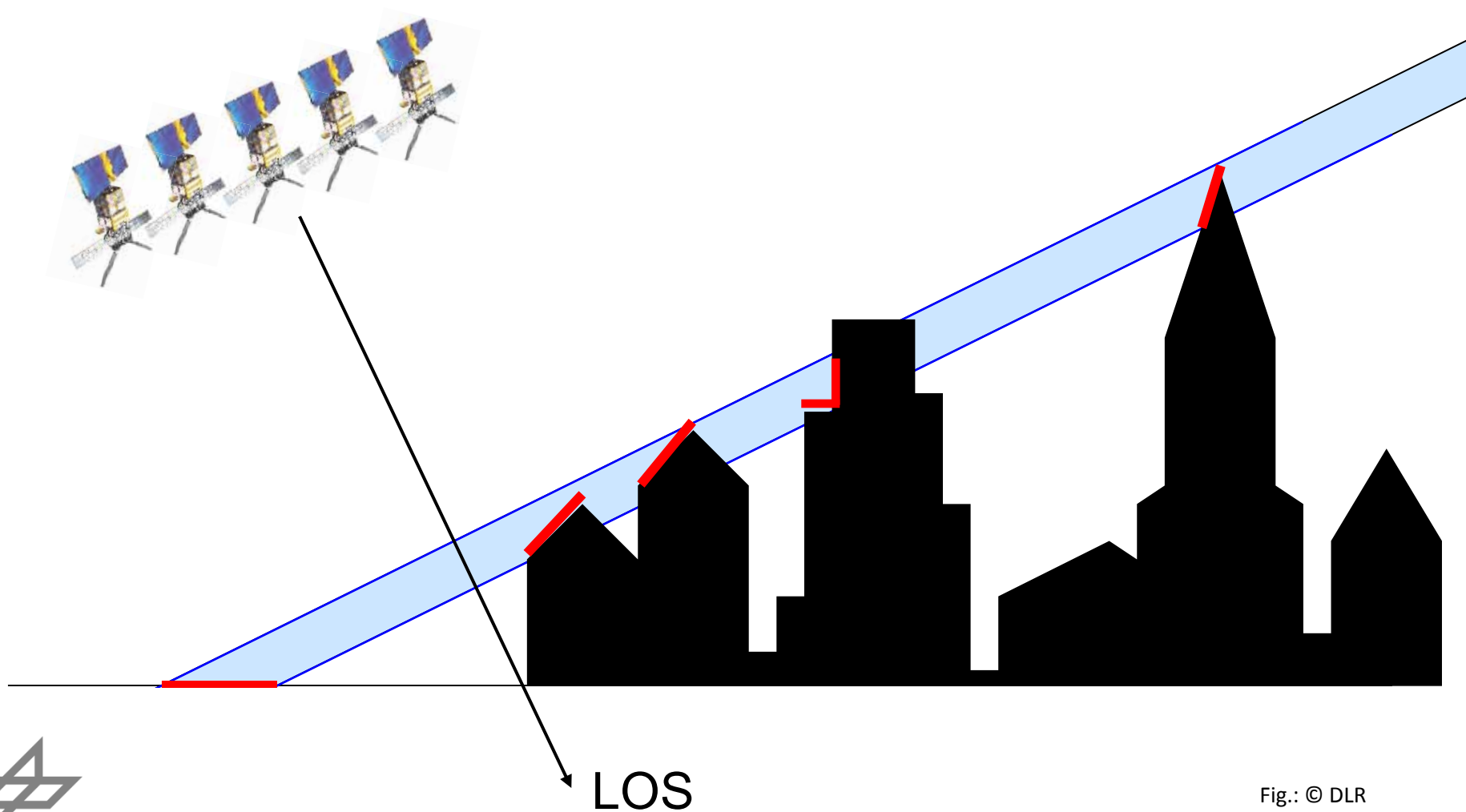

Fig.: © DLR

TS-X Intensity Map

Xiao Xiang
Zhu,
TUM/DLR



Single Scatterer Topography [m]

Xiao Xiang
Zhu,
TUM/DLR

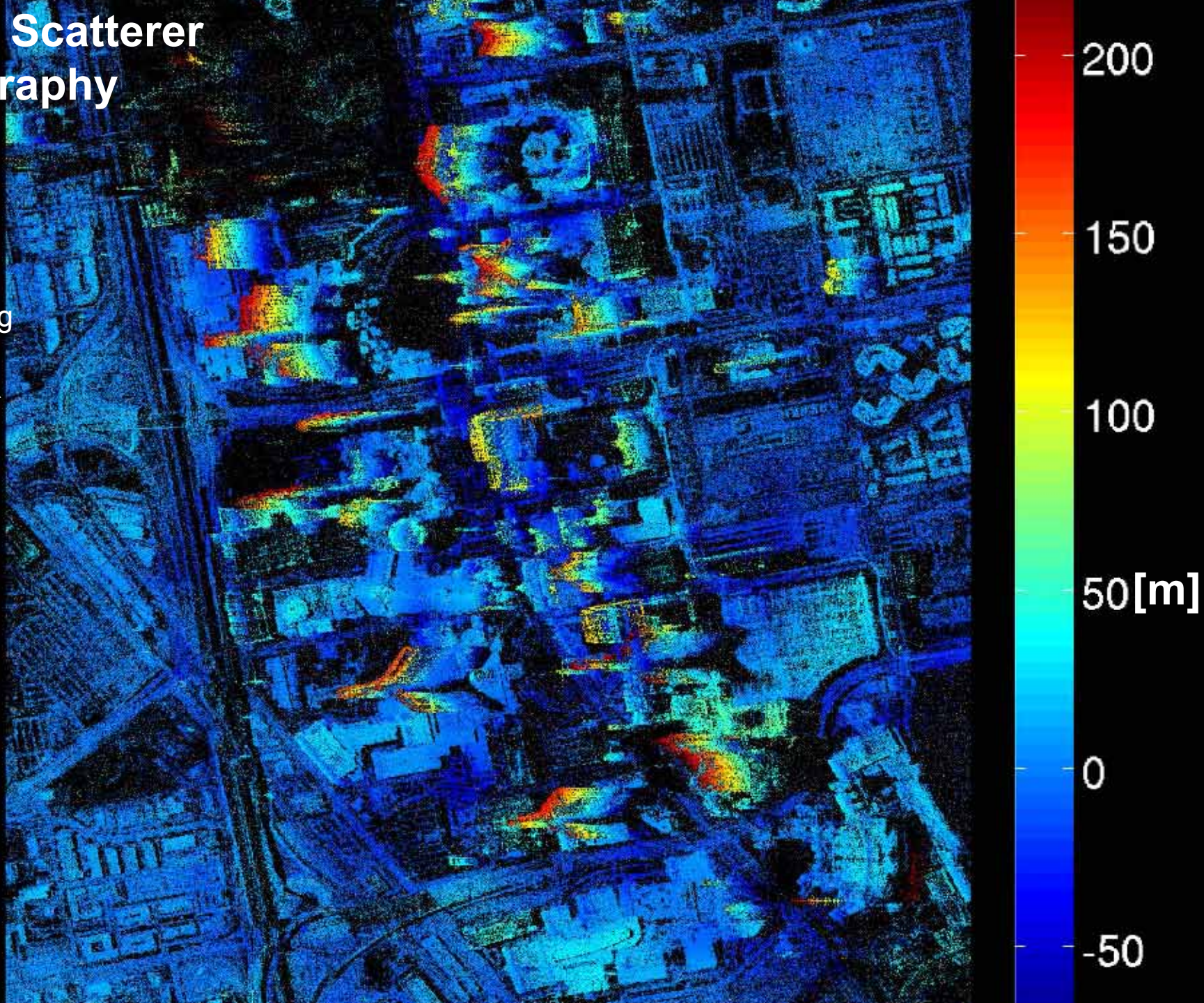

Double Scatterer (Facade) Topography [m]

Xiao Xiang
Zhu,
TUM/DLR

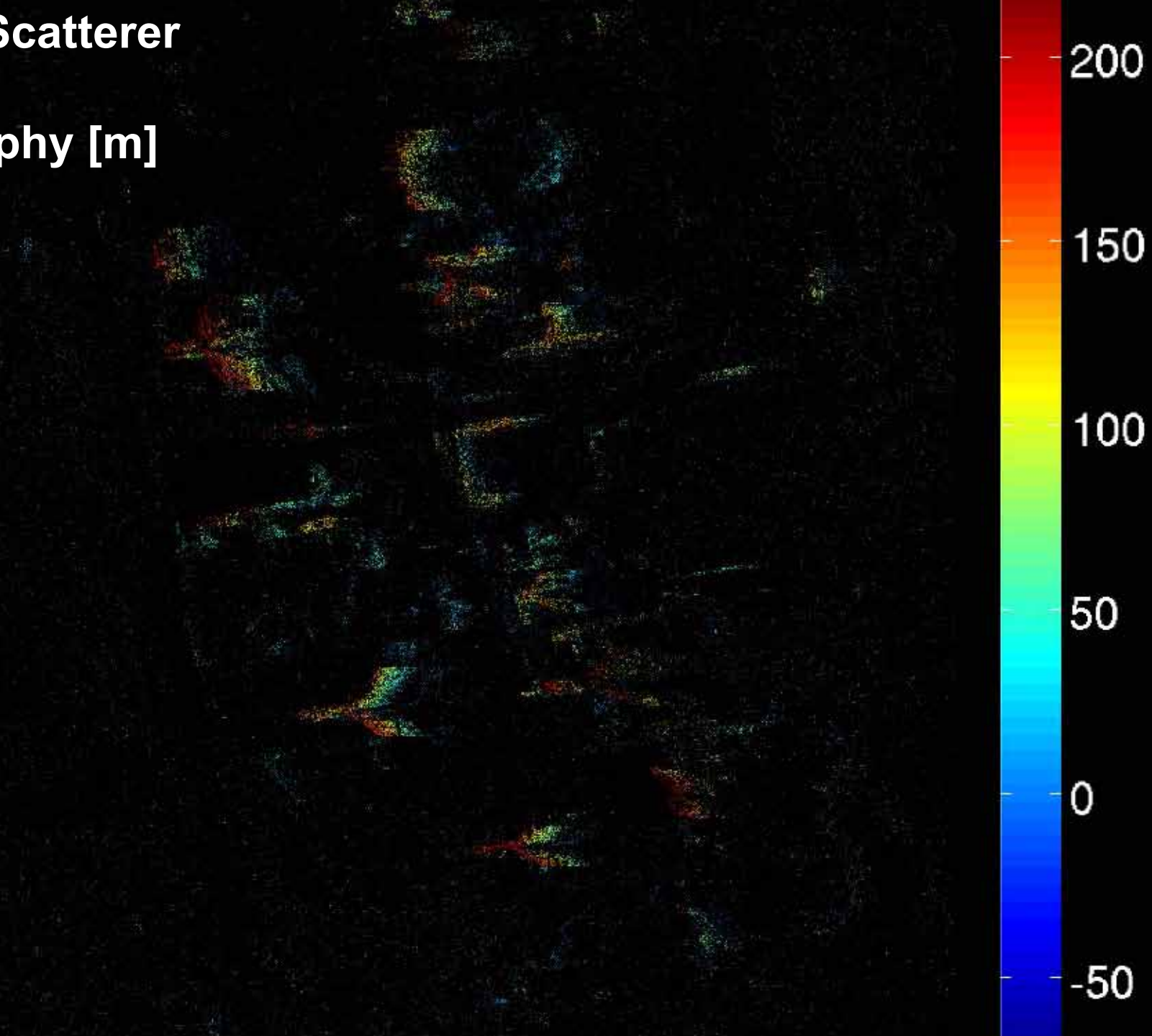

**Double Scatterer
(Ground)
Topography [m]**

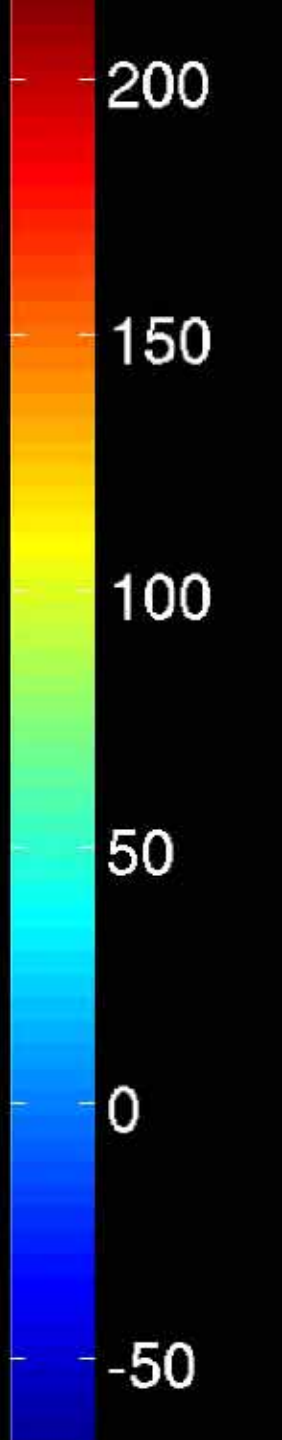
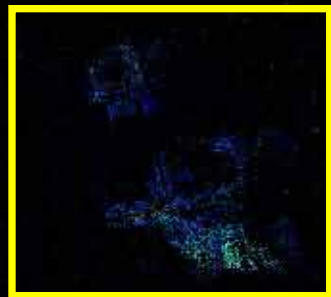

Structure

- Interferometric phase error sources
- Coherence and phase errors
- Geometric accuracy
- Distributed scatterers (geometric decorrelation)
- Temporal decorrelation
- Atmospheric errors
- Persistent Scatterer Interferometry
- Bistatic systems (TanDEM-X)

TanDEM-X Mission 2010+



- No mechanical coupling between satellites → smooth, well known baseline
- Same atmospheric path → no atmospheric error

Fig.: © DLR

Helix Orbit of TanDEM-X

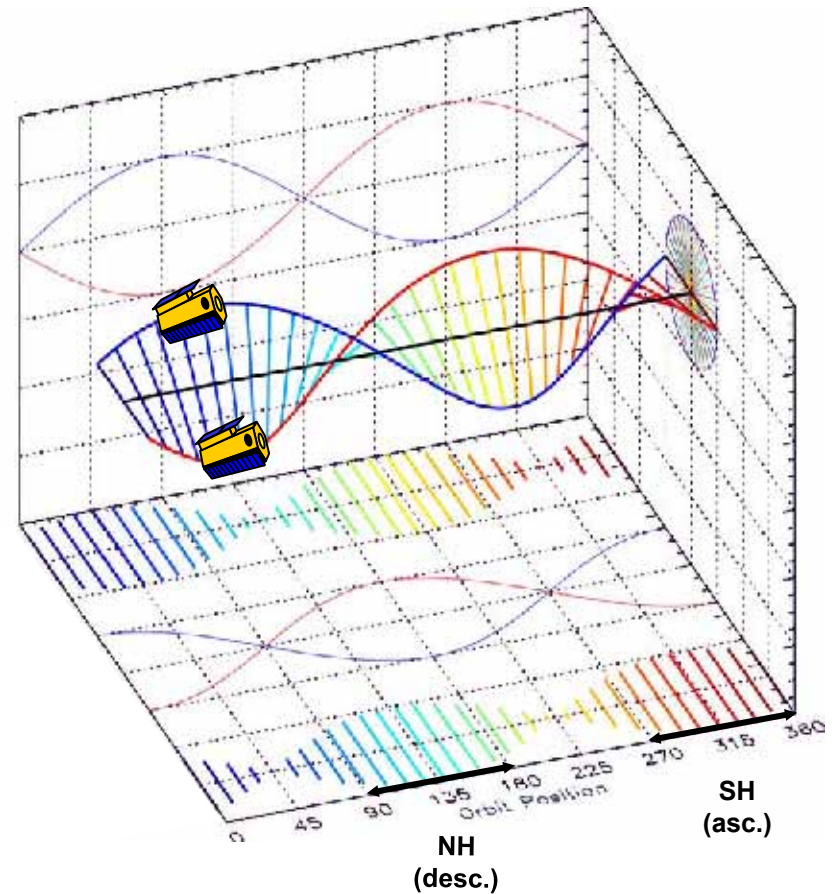
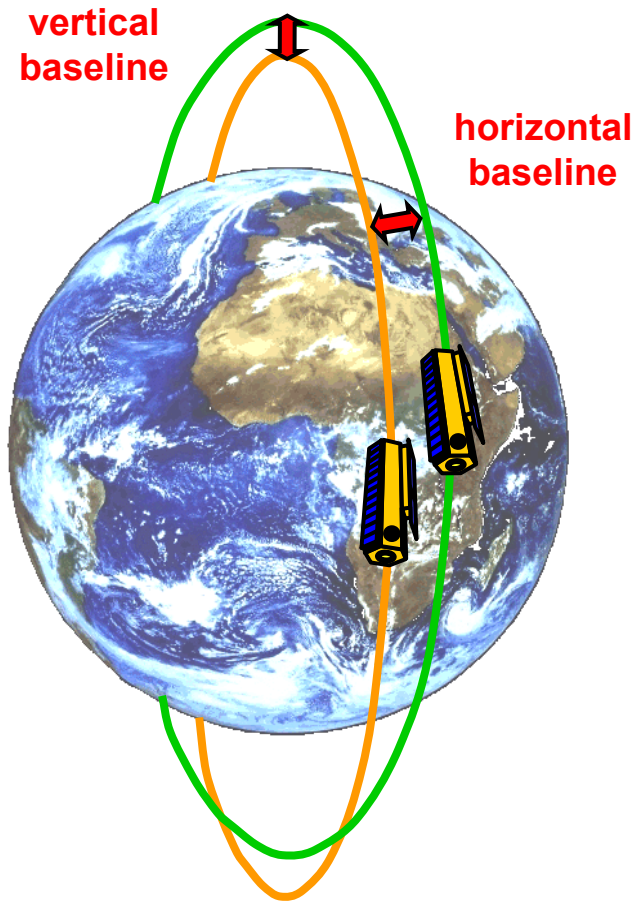

Fig.: © DLR

Bi-static TanDEM-X Synchronisation

- Different oscillators in bistatic operations
 - Large differential phase drift expected
 - Slightly different sampling frequencies
- Solution: synchronization link between satellites
- New processing algorithms for high accuracy interferometric processing required with a relative accuracy of 10^{-14}

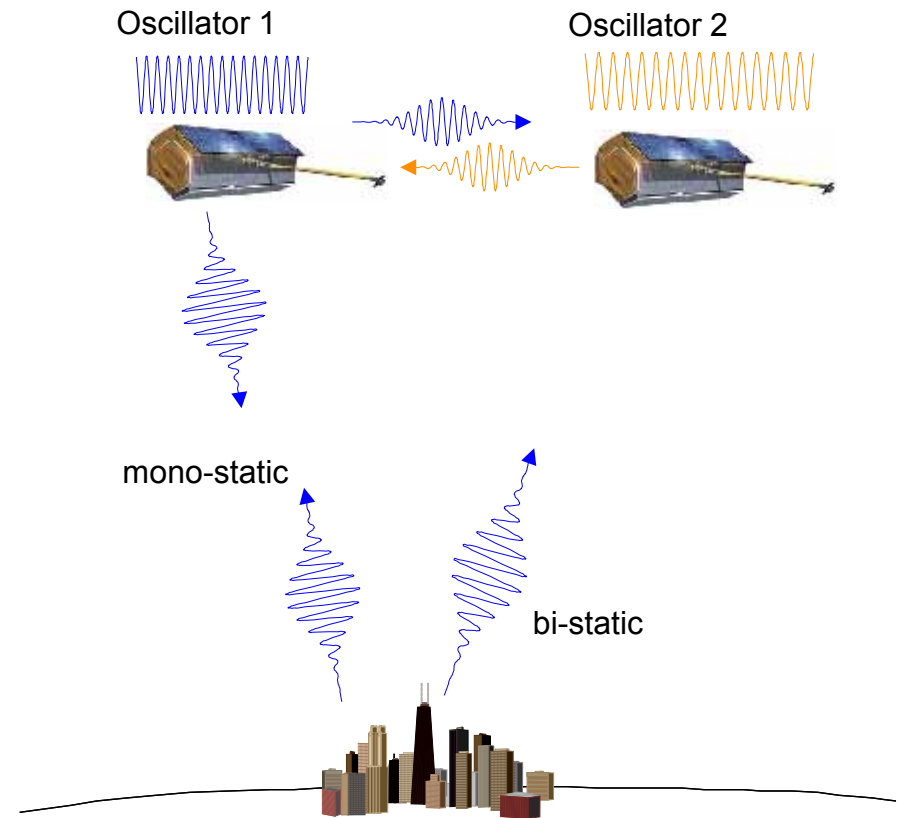

Fig.: © DLR



References

- Hanssen, R. F. (2001). *Radar Interferometry: Data Interpretation and Error Analysis* (Remote Sensing and Digital Image Processing Series, Vol. 2). Dordrecht: Springer Netherlands.
- Hanssen, R. F., Weckwerth, T. M., Zebker, H. A., & Klees, R. (1999). High-Resolution Water Vapor Mapping from Interferometric Radar Measurements. *Science*, 283(5406), 1297-1299.

SAR-EDU – SAR Remote Sensing Educational Initiative

<http://sar-edu.uni-jena.de/index.html>

Supported by:



Federal Ministry
of Economics
and Technology

on the basis of a decision
by the German Bundestag

Athena Summer School – SAR Software

Ramon Brcic

MF-SAR



Knowledge for Tomorrow

Public Software

Knowledge for Tomorrow



Overview

Public Software

Doris (Delft University, The Netherlands)	<u>DORIS</u>
GIANt - Generic InSAR Analysis Toolbox (Caltech)	<u>earthdef.caltech.edu/projects/giant/wiki</u>
GMTSAR (Scripps Institution of Oceanography)	<u>GMTSAR</u>
ISCE (JPL, Stanford University)	<u>ISCE</u>
RAT	<u>sourceforge.net/projects/radartools.berlios</u>
ROI_PAC (NASA/JPL, USA)	<u>ROI_PAC</u>
Sentinel-1 Toolbox (ESA)	<u>Sentinel-1 Toolbox</u>
SNAPHU (Stanford University, USA)	<u>SNAPHU</u>
StaMPS/MTI (University of Leeds, UK)	<u>STAMPS</u>



DORIS

doris.tudelft.nl

- Delft Object-oriented Radar Interferometric Software
- Developed by the [Delft Institute of Earth Observation and Space Systems](#) of [Delft University of Technology](#). Originally developed by Bert Kampes and Ramon Hanssen. Used by spin-off SkyGeo.
- Unix based, must compile
- Support for various sensors
- Support for InSAR but not advanced InSAR
- Requires various external libraries and add-ons for functionality, e.g. phase unwrapping requires SNAPHU add-on





[Home](#)

[Introduction](#)

[Status](#)

[Literature](#)

[Download](#)

[Brain Pool](#)

[Links](#)

The [Delft Institute of Earth Observation and Space Systems](#) of [Delft University of Technology](#) has developed an Interferometric Synthetic Aperture Radar (InSAR) processor named **Doris** (Delft object-oriented radar interferometric software). The **Doris** software can be downloaded *freely* from this site for non-commercial applications ([conditions](#)).

Interferometric products and endproducts such as Digital Elevation Models and displacement maps can be generated with this software from Single Look Complex data. Data from the satellites ERS, ENVISAT ([first ENVISAT interferogram](#), [54kB](#), [DEM](#), [107kB](#), and [perspective view](#), [177kB](#)), JERS ([first JERS interferogram](#)), and RADARSAT ([first RADARSAT interferogram](#)) can be processed with the **Doris** software.

Introduction - 24 December 2008

Introduction to interferometric processing with the **Doris** software.

Status - 24 December 2008

What's the current status of these pages and the **Doris** software.

Literature - 24 December 2008

Online publications and InSAR references
[FRINGE 2003 presentation](#),
[BAM Earthquake processing overview](#),
[Searchable InSAR literature](#) (bibtext file with ~2100 entries),

Download - 13 March 2012

Access to the **Doris** software
[User manual](#) (html - v4.02)
[User manual](#) (pdf - v4.02 [changelog](#))
[User manual](#) (pdf in Chinese - v3.16)

Brain Pool - 17 February 2010

Experienced users help answer questions from new users and processing strategies are discussed. We encourage you to join this list when you are using the **Doris** software. Users of other software packages are also welcome to join this list, in order to have as broad a platform as possible.

[Join the email list](#)

[FAQ for Doris](#) (Yahoo! group, member of aforementioned list to automatically collect all emails in a searchable archive).

Links - 24 December 2008

Interesting links.



Google Search

WWW Doris pages

This page is maintained by [TUDelft - MGP Radar Group](#), mail to: doris_users#@#tudelft.nl

Disclaimer: These pages contain links to sites outside DUT. We do not take responsibility for the contents of those sites.

GIAnT

earthdef.caltech.edu/projects/giant/wiki

- Generic InSAR Analysis Toolbox developed at Caltech
- *nix / Python based
- Supports advanced InSAR (time series analysis) through SBAS, N-SBAS and MInTS algorithms
- Takes as input a stack of unwrapped interferograms created with other software packages including ROI_PAC, DORIS, ISCE, GMTSAR
- Allows correction of orbital ramps, atmosphere



GIAnT

Hauptseite Projekte Hilfe Anmelden Registrieren

Earthdef::Giant Suche:

Wiki | [Dokumente](#) | [Dateien](#) | [Foren](#)

GIAnT - Generic InSAR Analysis Toolbox

GIAnT is a suite of Python libraries and scripts that implement various published time-series InSAR algorithms in a common framework. GIAnT was developed for

- 1. Rapid generation of time-series products from interferogram
- 2. Direct comparison of time-series InSAR products using different algorithms
- 3. Cal-Val for time-series InSAR

The toolbox currently includes implementations of SDAS, N-SDAS and MINTS algorithms. The toolbox also includes support for using PyAPS to correct stratified troposphere phase components and to use GPS solutions if available to correct for orbital errors.

- 1. **Installation**
- 2. Overview
- 3. User manual (Most recent version)
- 4. GIAnT test data
- 5. Citing this work



Wiki

Hauptseite
Seiten nach Titel sortiert
Seiten nach Datum sortiert



GMTSAR

topex.ucsd.edu/gmtsar

- Supports various sensors
- Supports InSAR and InSAR stacking
- Does not support advanced InSAR involving time series analysis – this is possible with other software that accepts GMTSAR outputs as inputs



[Home](#)

[Downloads](#)

[Generate DEM](#)

[Contact](#)

Links

[Get SAR data](#)

[GMT Hawaii](#)

An InSAR processing system based on GMT

David Sandwell - Scripps Institution of Oceanography
 Rob Mellors - San Diego State University
 Xiaopeng Tong - Scripps Institution of Oceanography
 Meng Wei - Scripps Institution of Oceanography
 Paul Wessel - University of Hawaii
 Looking for volunteers to develop scripts

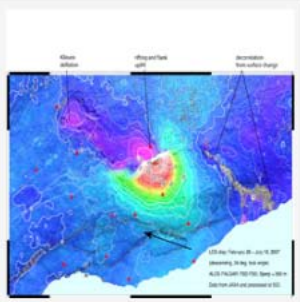

GMTSAR is an open source (GNU General Public License) InSAR processing system designed for users familiar with Generic Mapping Tools (GMT). The code is written in C and will compile on any computer where GMT and NETCDF are installed. The system has three main components:

1. a preprocessor for each satellite data type (ERS-1/2, Envisat, ALOS-1, TerraSAR-X, COSMOS-SkyMed, Radarsat-2, Sentinel-1A, and ALOS-2) to convert the native format and orbital information into a generic format;
2. an InSAR processor to focus and align stacks of images, map topography into phase, and form the complex interferogram;
3. a postprocessor, mostly based on GMT, to filter the interferogram and construct interferometric products of phase, coherence, phase gradient, and line-of sight displacement in both radar and geographic coordinates;

GMT is used to display all the products as postscript files and KML images for Google Earth. A set of C-shell scripts has been developed for standard 2-pass processing as well as image alignment for stacking and time series. ScansAR processing is also possible but requires a knowledgeable user. Users are welcome to contribute to this effort. In particular contributions using other scripting languages such as Perl and Python are desired.

CITATION: Sandwell, D. ., R. . Mellors, X. Tong, M. Wei, and P. Wessel (2011), Open radar interferometry software for mapping surface deformation, Eos Trans. AGU, 92(28), doi:10.1029/2011EO280002.

Sandwell, David, Mellors, Rob, Tong, Xiaopeng, Wei, Matt, & Wessel, Paul. (2011). GMTSAR: An InSAR Processing System Based on Generic Mapping Tools. UC San Diego: Scripps Institution of Oceanography. Retrieved from: <http://escholarship.org/uc/item/8zqz2c02m>

ACKNOWLEDGEMENTS: This research was supported by ConocoPhillips, the National Science Foundation, Scripps Institution of Oceanography, and San Diego State University.



ISCE

earthdef.caltech.edu/projects/isce_forum/wiki

- InSAR Scientific Computing Environment developed by JPL and Stanford University
- Sponsored by NASA for the geophysics community
- Builds on legacy software such as ROI_PAC
- Must register for use
- Supports various sensors (but not yet Sentinel-1?)
- Supports InSAR stacking but not advanced InSAR which can be performed with other software



ISCE

Earthdef::ISCEForum

Suche:

[Wiki](#) [Dokumente](#) [Dateien](#) [Forum](#)

ISCE - InSAR Scientific Computing Environment Forum

ISCE is a radar Interferometry toolbox/ package developed by IPT and Stanford University. ISCE can be obtained either through

1. [WINSAR](#) (or)
2. [Directly from IPT](#)

This is only a user forum and wiki for the project.

No ISCE source code will be distributed through this site.

This site will be used for bug tracking, feature requests and discussion of software issues related to ISCE.

- Report any build / install/ execution issues in the [Forums](#).
- Report any algorithm / features problems in the [Issues](#).

Wiki

[Hauptseite](#)

[Seiten nach Titel sortiert](#)

[Seiten nach Datum sortiert](#)



ISCE

winsar.unavco.org/portal/wiki/ISCE



[Home](#)

[InSAR WIKI](#)

[InSAR Archive](#)

[Log in](#)

InSAR Scientific Computing Environment (ISCE)

The InSAR Scientific Computing Environment (ISCE) is a modern framework for accurate, efficient processing of interferometric and polarimetric synthetic aperture radar (SAR) data. ISCE was developed at JPL, MIT, and Stanford under a NASA Advanced Information Systems and Technology program effort that ended in 2012. Integration with cloud computing is continuing through an effort called Cloud Enabled Scientific Computing Research Environment (CESCRE), under the NASA Computational Modeling Algorithms and Cyber-Infrastructure program. ISCE provides a computing environment for geodetic image processing for SAR sensors that will enable scientists to reduce measurements directly from radar satellites and aircraft to new geophysical products without first requiring them to develop detailed expertise in radar processing methods. The environment serves as the core of a centralized processing center to bring Level-0 raw radar data up to Level-0 data products, but is adaptable to alternative processing approaches for science users interested in new and different ways to exploit mission data. ISCE enables a new class of analyses that take greater advantage of the long time and large spatial scales of new data sets than current approaches.

Questions or problems with ISCE can be e-mailed to iscteams@gmail.com

A new Forum for ISCE users to ask questions has been added to the [Collective Earth Data ISCE](#) page, along with additional documents.

Using ISCE

- [Download ISCE](#)
- [ISCE Installation](#)
- [ISCE File Descriptions](#)
- [ISCE Framework Description](#)
- [ISCE Library Components](#)

Operational support provided by:



Sponsors of WInSAR activities:



RAT

sourceforge.net/projects/radartools.berlios

- Developed at Technical University of Berlin
- Uses IDL Virtual Machine, does not require a license for non-commercial use
- Only supports ENVISAT-ASAR format – aimed at PolSAR (ERS only VV, ENVISAT VV, HH, VV/HH, HV/HH, VH/VV)
- Supports PolSAR and InSAR but not advanced InSAR
- Documentation at: [RAT Radar Tools .pdf](#)



MAX RM Asset Tracking

Keep Track of Network Inventory for Your Clients Remotely--Free Trial!



Home / Browse / Science & Engineering / Earth Sciences / RAT - Radar Tools



RAT - Radar Tools beta

Brought to you by: [berliosrobot](#)

Summary Files

★ Add a Review

↓ 17 Downloads (This Week)

📅 Last Update: 2014-06-09

Tweet G+ 0

Gefällt mir

Download
rat_v0.21_source.tar.gz



[Browse All Files](#)

This is a BerliOS project. Check out the [BerliOS project page](#) for more information.



Description

RAT is a software for advanced image processing of SAR (Synthetic Aperture Radar) remote sensing data.

[RAT - Radar Tools Web Site](#)

Categories

[Earth Sciences, GIS](#)

License

[Mozilla Public License 1.1 \(MPL 1.1\)](#)



Advanced product configuration

Powerful. Constraint-based.

[Learn more...](#)



ROI_PAC

www.openchannelfoundation.org/projects/ROI_PAC

- Repeat Orbit Interferometry PACkage developed and maintained by Caltech/JPL
- Supports various sensors. Originally supported ESA ERS/ENVISAT, parsers extend support for current missions including Sentinel-1(A)
- Also supports focussing for some sensors (ERS, L0 → L3)
- Supports InSAR but not advanced InSAR
- Uses contributed software for phase unwrapping (SNAPHU), atmospheric correction, offset tracking, MAI
- Actively maintained





OPEN CHANNEL FOUNDATION

PUBLISHING SOFTWARE FROM ACADEMIC & RESEARCH INSTITUTIONS

Not Logged In | [Secure Login](#) | [New User](#)

Quick Application Search:

ROI_PAC

Foundation :: [Radar Imaging](#) :: ROI_PAC

Get this title!

- ▣ [Get ROI_PAC](#)
- ▣ [Monitor new releases](#)

Basic information

- ▣ [News](#)
- ▣ [ROI_PAC Forum](#)
- ▣ [Contributors](#)
- ▣ [Vision & Direction](#)
- ▣ [History](#)
- ▣ [Support](#)
- ▣ [Bugs](#)
- ▣ [Patches & Enhancements](#)

Additional resources

- ▣ [Active Tectonics Research](#)
- ▣ [Check out DGXI](#)
- ▣ [Credits](#)
- ▣ [Radar Interferometry Group](#)
- ▣ [ROI_PAC References](#)
- ▣ [ROI_pac Wiki](#)
- ▣ [SAR Research](#)

ROI_PAC [GET IT!](#)

Repeat Orbit Interferometry PACKAGE

Total downloads from Open Channel to date: **816**

✓ **SOURCE CODE AVAILABLE**

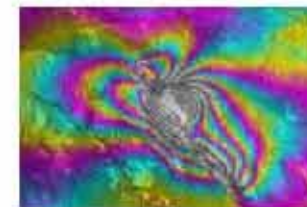

Moderators:

[Paul Rosen](#)
[Eric Fielding](#)

VERSION 3.0.1 IS HERE!!

(note that 3.0 was still the standard download until 1900 GMT (noon PDT) on 25 August 2009)

[Read the latest version Information here](#)

ROI_PAC V3.0.1, a Repeat Orbit Interferometry Package that allows researchers in the area of topography and surface change to apply Interferometric Synthetic Aperture Radar (InSAR) methods, is now freely available to the community. ROI_PAC, developed primarily to work with ERS data, currently supports ERS 1, ERS 2, JERS, Envisat and ALOS/PALSAR data, and is configurable to work with "strip-mode" data from all existing satellite radar instruments. InSAR is the synthesis of conventional SAR techniques and interferometry techniques that have been developed over several decades in radio astronomy and radar remote sensing, and in recent years has opened entirely new application areas for radar in the earth system sciences, including topographic mapping and geodesy [v. e.g., Thompson et al. 1986, Massonnet and Feigl 1998, Rosen et al. 2000]. The first release of ROI_PAC (V1.0) was made quietly in 2000, and roughly 30 groups in the academic and research community currently use it.

ROI_PAC uses raw radar data, ancillary information from telemetry and navigation solutions, and digital elevation models (DEM; externally provided or interferometrically derived) to produce a variety of derived data products, including the full resolution images, interferograms, phase images measured as principal value and continuously "unwrapped," DFMs, and error estimates. Each of the products is available in its natural radar coordinate system and georeferenced to a DEM. The software computes the interferometric

baseline (i.e. the orbital separation of the satellite at the observation times) from the provided navigation solutions, and then refines the estimate to the milli level of precision using the provided DEM and optional deformation model as reference. To remove the topographic signature from an interferogram, ROI_PAC simulates an interferogram from the orbit data and the DEM, and subtracts the phase from the measured interferogram, leaving just the deformation phase. ROI_PAC implements its fundamental algorithms in C and Fortran 90 and drives each executable module with a Perl control script, running on SGI, Sun, Mac OS X, and Linux platforms.

Copyright 2002, 2003, 2004, 2005, 2006, 2007, 2008, 2009, 2010, 2011, 2012, 2013, 2014 Caltech/Jet Propulsion Laboratory

[➤ More software from Jet Propulsion Laboratory](#)

Open Channel Software runs entirely on Open Source Software. We return value to the Software community in the form of services and original software. Most of our content is currently available as source code, with the copyright owned by the original author. All Rights Reserved. Everything else is Copyright ©2000 - 2010 Open Channel Software.



NSI

View our [privacy statement](#).

Contact [webmaster](#) at openchannelsoftware@jpl.nasa.gov with questions.

SNAPHU

web.stanford.edu/group/radar/softwareandlinks/sw/snaphu

- Statistical-cost, Network-flow Algorithm for PHase Unwrapping
- MCF based phase unwrapper
- Used as a plug-in phase unwrapper by other InSAR software packages



SNAPHU

SNAPHU: Statistical-Cost, Network-Flow Algorithm for Phase Unwrapping

Description

Two-dimensional phase unwrapping is the process of recovering unambiguous phase data from a 2-D array of phase values known only modulo 2π rad. SNAPHU is an implementation of the Statistical-cost, Network-flow Algorithm for Phase Unwrapping proposed by Chen and Zebker (see references below). This algorithm poses phase unwrapping as a minimum *a posteriori* probability (MAP) estimation problem, the objective of which is to compute the most likely unwrapped solution given the observable input data. Because the statistics relating the input data to the solution depend on the measured quantity, SNAPHU incorporates three built-in statistical models: for topography data, deformation data, and smooth generic data. The posed optimization problem is solved approximately with use of network-flow techniques. SNAPHU always produces complete unwrapped solutions, and, in our tests, its accuracy is comparable to or better than that of other available algorithms. An SNAPHU uses an iterative optimization procedure; its execution time depends on the difficulty of the interferogram. In single file mode the required memory is on the order of 100 MB per 1 000 000 pixels in the input interferogram. The software is written in C and should run on most Unix/Linux platforms. It is freely available to the public, subject to the conditions outlined in the README file included with the distribution.

The latest version of the code is 1.4.2 (February 2003).

Download

Download the full source distribution here: [snaphu-1.4.2.tar.gz](#) (gzipped tar file, 140 kB)

The following files are included in the full distribution, but are listed separately here as well for convenience.

Distribution README file: [README](#) (text, 5 kB)

Text version of main page: [snaphu_main.txt](#) (text, 30 kB)

HTML version of main page: [snaphu_main.html](#) (text, 48 kB)

Full template runtime configuration file: [snaphu.conf.full](#) (text, 13 kB)

Brief template runtime configuration file: [snaphu.conf.brief](#) (text, 11 kB)

References

C. W. Chen and H. A. Zebker, "Network approaches to two-dimensional phase unwrapping: tractability and two new algorithms," *Journal of the Optical Society of America A*, vol. 17, pp. 401-411 (2000). [[Go](#)]

C. W. Chen and H. A. Zebker, "Two-dimensional phase unwrapping with use of statistical models for cost functions in nonlinear optimization," *Journal of the Optical Society of America A*, vol. 18, pp. 1332-1337 (2001). [[Go](#)]

C. W. Chen and H. A. Zebker, "Phase unwrapping for large SAR interferograms: Statistical segmentation and generalized network models," *IEEE Transactions on Geoscience and Remote Sensing*, vol. 40, pp. 1709-1719 (2002). [[Go](#)]

STAMPS

homepages.see.leeds.ac.uk/~earahoo/stamps

- Stanford Method for Persistent Scatterers developed by Andy Hooper (currently at University of Leeds)
- Relies on ROI_PAC for focusing, DORIS for InSAR
- Combination of MatLab scripts and C++ modules
- Supports PS Processing and Small Baseline Processing
- Both methods can be combined in MTI Processing



STAMPS

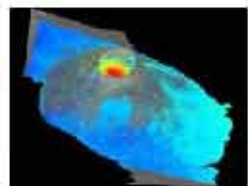

STAMPS

A software package to extract ground displacements from time series of synthetic aperture radar (SAR) acquisitions.

The original version was developed at Stanford University but subsequent development has taken place at the University of Iceland, Delft University of Technology and the University of Leeds.

The package incorporates persistent scatterer and small baseline methods plus an option to combine both approaches.

[Andy Hooper](#)

School of Earth and Environment
University of Leeds
Leeds LS2 9JT

12th September, 2013

A new beta release version of StaMPS/MTI (version 3.3b1) is available as [StaMPS_v3.3b1.tar.gz](#) (extract with `tar -zxvf`).

The manual of StaMPS/MTI (version 3.3b1) is available as a [pdf file](#).

24th November, 2010

A new release version of StaMPS/MTI (version 3.2) is available as a "tar.gz file" (extract with `tar -zxvf`).

* StaMPS/MTI version 3.2 is updated to version 3.2.1 on 26th November, 2010.

3rd March, 2010

A new beta version of StaMPS/MTI (version 3.2b4) is available as a [tar.gz file](#) (extract with `tar -zxvf`).

9th December, 2009

A new beta version of StaMPS/MTI (version 3.2b3) is available as a [tar.gz file](#) (extract with `tar -zxvf`). An updated manual is included in the zip file.

15th July, 2009

StaMPS/MTI (version 3.1) is available as a [tar.gz file](#) (decompress with `gunzip`, then extract with `tar -zxvf`). This software may be downloaded freely for non-commercial applications. Click to view the [manual](#) (also included in the download). Some literature referring to the software can be found [here](#).

If you use this code, please join the user group [MAIN SAR](#) to be informed of any updates/issues. Also, please post any questions or advice to this group rather than directly to me.

[Andy Hooper](#)

ESA Software STEP, SNAP and the Sentinel-1 Toolbox

Knowledge for Tomorrow



STEP – Science Toolbox Exploitation Platform

<http://step.esa.int/main/toolboxes/snap/>

step
science toolbox exploitation platform

esa

ESA STEP TOOLBOXES DOWNLOAD GALLERY DOCUMENTATION COMMUNITY THIRD PARTY PLUGINS

Search...

Home > Scientific Toolbox Exploitation Platform

multimission scientific toolboxes

ESA is developing **free open source toolboxes** for the scientific exploitation of **Earth Observation missions** under the the Scientific Exploitation of Operational Missions (SEOM) programme element. **STEP** is the ESA **community platform** for accessing the software and its documentation, communicating with the developers, dialoguing within the science community, promoting results and achievements as well as providing tutorials and material for training scientists using the Toolboxes.

The ESA toolboxes support the **scientific exploitation** for the **ERS-ENVISAT** missions, the **Sentinels 1/2/3** missions and a range of **National** and **Third Party** missions. The three toolboxes are called respectively Sentinel 1, 2 and 3 Toolboxes and share a common architecture called **SNAP**. They contain some functionalities of historical toolboxes such as ULAM, NLSI and Orfeo toolbox that were developed over the last years.

2017

2016

→ SNAP SURVEY

→ POLI RSAR 2017 WORKSHOP

→ DOLBY AND LIGHT IN THE LIGHT FROM THE WALKER

STEP – Science Toolbox Exploitation Platform

- ESA is developing free open source toolboxes for the scientific exploitation of Sentinel data
- These toolboxes expand on and consolidate existing software and functionality
 - Support for ERS/ENVISAT
 - Support for national and third party missions such as TerraSAR-X
- STEP is a community platform providing an entry-point to the various Sentinel toolboxes



SNAP – SeNtinel Application Platform

step

science toolbox exploitation platform



ESA

STEP

TOOLBOXES

DOWNLOAD

GALLERY

DOCUMENTATION

COMMUNITY

THIRD PARTY PLUGINS

SNAP

Sentinel 1 Toolbox

Sentinel 2 Toolbox

Sentinel 3 Toolbox

SMOS Toolbox

Download

Community

Useful Links



[Home](#) > [Toolboxes](#) > SNAP

SNAP

A common architecture for all Sentinel Toolboxes is being jointly developed by Brockmann Consult, Array Systems Computing and C-S called the **Sentinel Application Platform** (SNAP).

The SNAP architecture is ideal for Earth Observation processing and analysis due to the following technological innovations: Extensibility, Portability, Modular Rich Client Platform, Generic I/O Data Abstraction, Tiled Memory Management, and a Graph Processing Framework.

Feature Highlights

- Common architecture for all Toolboxes
- Very **fast image display and navigation** even of 4096 pixel images
- Graph Processing Framework (GPF): for creating user-defined processing chains
- Advanced **layer management** allows adding and manipulation of new overlays such as images of other bands, images from WMS servers or ESRI shapefiles
- Rich **capabilities of internet definitions** for statistics and various plots

Search...



scientific exploitation of operational missions

2017



ESA POLiRSAR 2017 Workshop

2016



SNAP – SeNtinel Application Platform

- SNAP (Sentinel Application Platform) is the commercially developed common architecture for the Sentinel toolboxes
- Common libraries released under the [GNU GPL-3](#)
- Support for very large images
- Layer management (WMS servers, ESRI shapefiles)
- SRTM DEM access



Sentinel-1 Toolbox – S1TBX

step

science toolbox exploitation platform



ESA
STEP
TOOLBOXES
DOWNLOAD
GALLERY
DOCUMENTATION
COMMUNITY
THIRD PARTY PLUGINS

- SNAP
- Sentinel 1 Toolbox
- Sentinel 2 Toolbox
- Sentinel 3 Toolbox
- SMOS Toolbox
- Download
- Community
- Useful Links



[Home](#) > [Toolboxes](#) > [Sentinel 1 Toolbox](#)

Sentinel 1 Toolbox



The Sentinel-1 Toolbox (S1TBX) consists of a collection of processing tools, data product readers and writers and a display and analysis application to support the large archive of data from ESA SAR missions including SENTINEL-1, ERS-1 & 2 and ENVISAT, as well as third party SAR data from ALOS PALSAR, TerraSAR-X, COSMO-SkyMed and RADARSAT-2. The various processing tools could be run independently from the command-line and also integrated within the graphical user interface. The Toolbox includes tools for calibration, speckle filtering, coregistration, orthorectification, mosaicking, data conversion, polarimetry and interferometry.

The Sentinel 1 Toolbox is being developed for ESA by [Array Systems Computing](#) in partnership with DLR, Brockmann Consult and OceanDataLab.



scientific exploitation
of operational missions

2017



ESA POLInSAR 2017 Workshop

2016



"DARK AND LIGHT IN THE
LIGHT FROM ALL POINTS"

© ESA – European Space Agency

Sentinel-1 Toolbox – S1TBX

SNAP

Sentinel 1 Toolbox

Sentinel 2 Toolbox

Sentinel 3 Toolbox

SMOS Toolbox

Download

Community

Useful Links



[Home](#) > [Toolboxes](#) > [Sentinel 1 Toolbox](#) > S1TBX Features

S1TBX Features

Supported SAR Missions

- SENTINEL-1, ENVISAT ASAR, ERS-1/2, RADARSAT-2, ALOS-1/2, Cosmo-SkyMed, TerraSAR X/Tandem X

Processors

- All general EO processors from SNAP (Subset, Resample and Band Arithmetic, etc.)
- Absolute calibration (SENTINEL-1, ENVISAT ASAR, ERS 1&2, ALOS, RADARSAT-2, TerraSAR X, Cosmo SkyMed)
- Multilooking & speckle (single and multitemporal) filtering
- Precise orbit handling (SENTINEL 1, Doris, Prare and Delft orb.)
- Coregistration of detected and complex products
- Sentinel-1 TOPS Interferometry, debursting, slice assembly
- Range-Doppler Terrain Correction
- Radiometric normalization during Terrain Correction
- SAR simulation and layover and shadow masks
- Simulated SAR Terrain Correction
- Ellipsoid correction, Map Reprojection, Mosaicking
- Ocean tools: basic routines for oil spill detection, ship detection and wind field estimation from SAR data
- Fully Integrated and featured InSAR processor (Jlinda) for Strimap and Zero-Doppler focused data
- Quad-Pol and Dual-Pol matrix conversion, speckle filtering, decompositions and classifiers
- Compatibility with PolSARpro Toolbox (Reader, Writer)

Search...

seom
scientific exploitation
of operational missions

2017



ESA POLInSAR 2017 Workshop

2016



Colour and Light in the Ocean from
Earth Observation



Earth Observation Open Science

Sentinel-1 Toolbox – S1TBX

- Released under [GNU GPL-3](#) source code available on [GitHub](#)
- Runs under Windows, Mac OS X, Unix
- Links to installation guide, documentation, tutorials, Wiki, forum, blog from STEP or from the software itself



S1TBX Replaces NEST (Next ESA SAR Toolbox)



Login Register

NEST Home Downloads Documents Development User Community

You are here Home

Share | t f t e

NEST - next esa sar toolbox



The Next ESA SAR Toolbox (NEST) is an ESA open source toolbox under the GNU GPL licence for reading, processing, analysing and visualising ESA (ERS-1/2, ENVISAT, SENTINEL-1) and other spaceborne* (TerraSAR-X, RADARSAT 1-2, COSMO-SkyMed, JERS-1, ALOS PALSAR) SAR data processed to Level-1 or higher.

NEST is now replaced with the Sentinel-1 Toolbox for all missions. Please visit the [Sentinel Toolbox website](#) for the latest software.

Main Features

Latest News

- S-1A initial products available
- NEST 5.1 Released
- SOCIS 2014
- SENTINEL-1 Readers and Data
- DEM Generation with NEST

Forum Posts

- Processing ALOS-2 level 1.5 data
- How to extract coherence and covariance
- GEOCODING S1-A SLC IW DATA
- Applying orbit file for Sentinel1 SLC data using
- TerraSAR EEC Geocoding Problem
- Mask layer statistics
- Error Computation of interferogram and

Tutorials

- SNAP
- Sentinel 1 Toolbox
- Sentinel 2 Toolbox
- Sentinel 3 Toolbox
- SMOS Toolbox
- Download
- Community
- Useful Links



[Home](#) > [Documentation](#) > [Tutorials](#)

Tutorials

[SNAP Tutorials \(General toolbox usage\)](#)

[Sentinel-1 Toolbox Tutorials \(SAR applications\)](#)

[Sentinel-2 Toolbox Tutorials \(High resolution optical applications\)](#)

[Sentinel-3 Toolbox Tutorials \(Medium resolution optical applications\)](#)

External Resources

[LearnEO \(Earth Observation with ESA\)](#)

[SAREdu \(SAR applications\)](#)

[UN-SPIDER \(Flood mapping using SNAP\)](#)

[S1TBX Course \(@ Satellite Applications Catapult\)](#)

Search...



2017



ESA POLinSAR 2017 Workshop

2016



Colour and Light in the Ocean from Earth Observation



Earth Observation Open Science

Other Sources

Knowledge for Tomorrow



Other Sources

- Software tools for working with TerraSAR-X data compiled by AIRBUS Defence & Space

<http://www.geo-airbusds.com/en/3018-software-tools>

- Software tools for remote sensing compiled by ASF (Alaska Satellite Facility), USA (homepage at www.asf.alaska.edu)

<https://www.asf.alaska.edu/data-tools/other-software-tools>

- Software tools compiled by UNAVCO (www.unavco.org, non-profit university-governed consortium supporting geoscience research and education)

www.unavco.org/software/data-processing/sar-software/sar-software.html



Other Sources

earthdef.caltech.edu

Hauptseite Projekte Hilfe Anmelden Registrieren

Earthdef Suche:

Hauptseite

Caltech's Earth Deformation Software and User Forums

This page provides access to Earth surface deformation modeling tools that were developed at Caltech. **Registered users** can access the latest version of the code repository using svn. All software on this site are distributed on these terms.

The following packages are currently hosted on this website.

1. PyAPS - Python based Atmospheric Phase Screen Estimation

[Click here for wiki page, user manual, repository and user forum access.](#)

2. Yarres - Variable Resolution Interferogram Resampler

[Click here for wiki page, user manual, repository and user forum access.](#)

3. GIANT - Generic InSAR Analysis Toolbox

[Click here for wiki page, user manual, repository and user forum access.](#)

4. ISCE (JPL/Stanford) User Forum

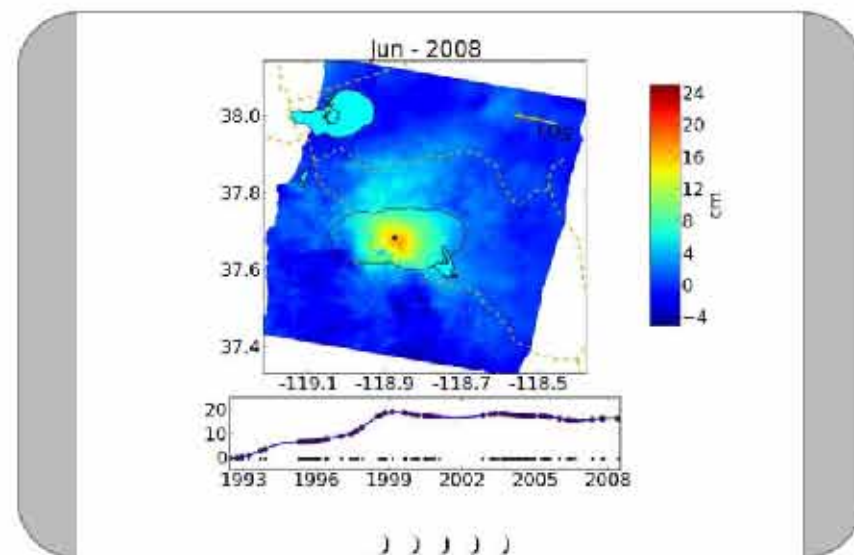

WInSAR

winsar.unavco.org

- Western North America InSAR (WInSAR) Consortium
- Collaboration between universities, research laboratories, and public agencies seeks to use promote radar remote sensing for earth sciences (tectonics)
- Concentrates on acquisition and archiving of spaceborne SAR data over western North America
- Hosts software and provides many links to other software / information



Other Sources

winsar.unavco.org/portal



WInSAR
Western North America Interferometric
Synthetic Aperture Radar Consortium

Home InSAR WIKI InSAR Archive Login

Welcome to the WInSAR Portal

This portal provides a WIKI for the community, management of proposals for WInSAR PIs, tracking of TSX tasking for WInSAR and Supersites, and user management and password reset.

From here your options are to [Login](#) or [Reset your password](#) on an existing account or [Register](#) for a new account .
Authenticated users have other options to navigate through the portal using the links in the top right.

Operational support provided by:



Sponsors of WInSAR activities:



Other Sources

winsar.unavco.org/portal/wiki/WikiIndex



The screenshot shows the homepage of the WInSAR (Western North America Interferometric Synthetic Aperture Radar Consortium) Wiki. The header features the WInSAR logo and navigation links for Home, InSAR WIKI, and InSAR Archive. The main heading is "Welcome to the InSAR Processing Wiki". Below this, a paragraph explains that this is a new wiki for sharing software and tips for processing SAR data, and that some information from the ropac.org wiki has been updated and incorporated. A "Table of Contents" section lists various topics such as SAR Processing Software Packages (including ISCE, GMTSAR, and ROI_PAC), Satellite Information, Data Archives and Access to data, Contributed software, Advanced Techniques (including InSAR Time Series Analysis, Multiple Aperture Interferometry, Dense sub-pixel offset tracking, and Preparing Data for Modeling), Data Visualization, Bibliography, and External Links. At the bottom, it states "Operational support provided by: UNAVCO" with the UNAVCO logo.

WInSAR

Western North America Interferometric Synthetic Aperture Radar Consortium

Home InSAR WIKI InSAR Archive Login

Welcome to the InSAR Processing Wiki

This is a new wiki for the community to share software and tips for processing SAR data. Some of the information from the ropac.org wiki has been updated and incorporated with the content here. If you want to contribute, you will need a [WInSAR](#) account and some instructions for formatting are given in the [WikiHowTo](#).

Table of Contents

- SAR Processing Software Packages
 - ISCE
 - GMTSAR
 - ROI_PAC
- Satellite Information
- Data Archives and Access to data
- Contributed software
- Advanced Techniques
 - InSAR Time Series Analysis
 - Multiple Aperture Interferometry
 - Dense sub-pixel offset tracking
 - Preparing Data for Modeling
- "Data Visualization"
- Bibliography
- External Links

Operational support provided by:
UNAVCO



Welcome to Radar Remote Sensing

- Have you ever asked yourself how it is possible to estimate earthquake hazards or to forecast volcanic eruptions?
- Would you like to know how to measure the movement of glaciers with centimeter accuracy?
- Or do you wonder how much forest we have left on our planet?

Synthetic Aperture Radar (SAR) provides a powerful tool to give answers to these and many other scientific questions.

We kindly invite you to join the exciting world of microwave and active satellite technology for the purpose of observing our dynamic Earth. We are addressing an increasing and advanced society, built structures and stations which are interrogated by satellite derived radar imagery and used to learn more about its acquisition, processing, and application.

[Read More](#) | [Browse Materials](#) | [Join the Community](#)



SAR-EDU remote sensing education initiative



SAREDU

saredu.dlr.de

- Supported by German Federal Ministry for Economic Affairs and Technology (BMWi)
- Joint initiative coordinated by Friedrich-Schiller University Jena and DLR with contributions from public institutions and private industry
- Provides training on the use of SAR, courses held yearly in Sep/Oct in Jena, Germany
- Covers basics (e.g. mathematics and physics), methods (e.g. InSAR, PolSAR) and many application areas of SAR
- Check list of units at saredu.dlr.de/unit and register to view lessons (videos)



SAREDU



Login / Register

Search...



HOME

UNITS

RESOURCES ▾

ABOUT ▾

CONTACT ▾

Home / Resources

Software

Various software solutions are available for reading, processing and analyzing SAR data. This section gives you an [overview](#) of available software packages.

SAR Software

You can find various tutorials for a selection of the presented software in the [Units section](#). Currently, SAR-EDU is offering tutorials for **GAMMA**, **NEST**, **SARscape**.

DORIS software by **TU Delft**
Multi-University of Technology

GAMMA software by **GAMMA REMOTE SENSING**

MAPREADY software by **UAF**
UNIVERSITY OF ALASKA
FAIRBANKS

nest next esa sar toolbox
NEST software by **esa**

POLARPRO software by **esa**
The Polarimetric SAR Data Processing and Educational Tool

ROI_PAC software by **JPL**

SARscape software by **EXELIS**
Visual Information Systems

Commercial Software

Knowledge for Tomorrow



Overview

Commercial Software	
Diapason (Altamira Information)	Altamira Information
Geomatica Radar-Suite (PCI Geomatics, Canada)	Geomatica Radar-Suite
ERDAS IMAGINE (Hexagon Geospatial, Stockholm, Sweden)	ERDAS-Imagine
GAMMA software (Switzerland)	GAMMA RS
SARscape for ENVI (Harris Geospatial Solutions, USA)	ENVISARscape



DIAPASON

Altamira Information

- Originally developed by CNES, the French space agency
- Now developed by Altamira Information
- Supports (at least) ESA missions ERS-1/2, ENVISAT, Sentinel-1
- Supports InSAR but not advanced InSAR
- Altamira uses in-house SPN (Stable Point Network) software for PSI



Altamira Information – DIAPASON



Sentinel-1 data are already supported by GlobalSAR™ ALTAMIRA INFORMATION's advanced processing chain.

READ MORE



MEASURING GROUND MOTION FROM SPACE



InSAR Technology

Remote measurement of ground motion with high resolution radar images.



GlobalSAR™

Our new advanced processing chain based on InSAR technology.



Data Management

Our tools to visualize and handle GlobalSAR™ ground motion maps.

PCI Geomatica

Geomatica Radar-Suite

- Supports SAR and PolSAR analysis for various sensors
- No InSAR capability



PCI Geomatica



- Software
- Resources
- Buy Now
- About Us
- Support



Radar Suite

Start Working with SAR Imagery Today!

Fully Functional Trial

Try Geomatica

See What You've Been Missing

Because of its all-weather, any-time monitoring capabilities, Radar remote sensing offers a number of advantages for Earth surface and feature observation. The Geomatica Radar Suite is purpose-built to provide tools specialized for processing radar data in a standard remote sensing or GIS environment. The outputs from PCI Geomatics radar tools can be combined with other microwave and optical sensors as well as vector data to maximize the utility of information. Being part of the full-Geomatica system means this integration is seamless and simple.

capitool

Chat with us

Ask your message here

ERDAS Imagine

ERDAS-Imagine

- Support for some sensors (none for Sentinel-1, ERS-1/2, ENVISAT in 2015 Product Features and Comparisons)
- Supports basic InSAR but not advanced InSAR (stacking, time series analysis)



ERDAS Imagine



ERDAS IMAGINE

ERDAS IMAGINE is offered within the Producer Suite of the Power Portfolio.



The World's
Leading
Geospatial Data
Authoring System

Tools for all your Remote Sensing,
Photogrammetry and GIS
processing needs.

GAMMA

GAMMA RS

- Developed by GAMMA Remote Sensing
- Supports various sensors
- Supports InSAR and advanced InSAR (PSI)
- Training offered by GAMMA Remote Sensing
- Offer customised services – value-adding



Software

- [Software News](#)
- [System Overview](#)
- [MSP Modular SAR Processor](#)
- [ISP Interferometric SAR Processor](#)
- [DIFF&GEO Differential SAR Processor & Geocoding](#)
- [IPTA Interferometric Point Target Analysis](#)
- [GEO Geocoding Software](#)
- [LAT Land Application Tools](#)
- [DISP Display Tools](#)

GAMMA Software

The GAMMA SAR and Interferometry Software is a collection of programs that allows processing of SAR, interferometric SAR (InSAR) and differential interferometric SAR (DInSAR) data for airborne and spaceborne SAR systems. The software supports the entire processing from raw data to high level products such as digital elevation models, displacement maps, point target analysis and landuse maps. The software is arranged in [packages](#), each dealing with a specific aspect of the processing. → [Learn more...](#)

The GAMMA Software runs on any Unix or Linux system as well as on Win32-based platforms (W2K, Windows XP). Recommended OS is Linux. Any distribution should work as long as the GTK toolkit is version 2.8.12 or higher. A nice free distribution is [Ubuntu](#). Both 32- and 64-bit processors are supported on Linux. On Windows and Solaris a 32-bit environment is needed. The GAMMA Software is also known to run on OS-X and other *IX systems. [Contact GAMMA](#) if you have special needs.

With its functionality, flexibility, robustness, efficiency, and competitive price, GAMMA software is an excellent solution for demanding processing jobs. This has been demonstrated by license sales to users at many leading institutes world-wide, since 1995. Another distinct advantage of the GAMMA software is the competent user support provided directly by the developers and experienced users of the software and the availability of [ad-hoc](#) and [training courses](#).

<http://www.gamma-rs.ch>

Examples

30.01.08 11:28

Support of Radarsat2 SLC data

GAMMA Software supports Radarsat2 SLC data.

[\[more\]](#)

26.05.15 16:51

Nepal Earthquakes Palsar-2 Interferograms

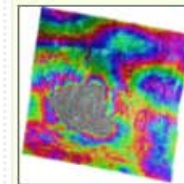

A devastating earthquake of magnitude 7.8 occurred in Nepal on 25 April 2015. On 12 May...

[\[more\]](#)

25.04.04 09:55

Montagnon

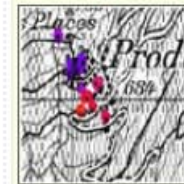

Montagnon: IPTA deformation mapping.

[\[more\]](#)

GAMMA – Training



[Sitemap](#) [Search](#) [Contact](#)

- [Gamma](#)
- [Services & Products](#)
- [Research & Development](#)
- [Software](#)
- [Courses](#)
- [Support](#)

You are here: [Courses](#) / [Upcoming courses](#)

11.5.2016 : 12:13 : +0200   

Courses

- Training courses
- Upcoming courses**
- Future courses
- Past courses
- Ad-hoc courses

Upcoming Training Courses

Training course on Interferometric Point Target Analysis - spring 2016

Sunday 13. September 2015

Course on
**Interferometric Point Target Analysis
(IPTA)**
Principles and processing approach
23 – 28 May 2016

Practical training with the GAMMA Software [\[more\]](#) [\[more\]](#)

SARscape

ENVISARscape

- Developed by sarmap
- Supports spaceborne and airborne SAR sensors
- Supports InSAR and advanced InSAR (SBAS/PSI)
- Offered as an add-on for ENVI from [Harris Geospatial Solutions](#) though its subsidiary Exelis Inc. through its subsidiary Exelis VIS ...
- [SAR Analysis Made Easy with ENVI SARscape 5.1](#)
- Training offered through Harris Geospatial Solutions



sarmap – sarscape



the earth observation gateway

- Home
- Company
- Software
- Products & Services
- Capacity Building

SARscape

Synthetic Aperture Radar (SAR) systems can acquire data in different ways, such as:

- Single or dual channel mode (for instance HH/HV or VV/VH);
- Interferometric (single- or co-pass) mode;
- Polarimetric mode (HH, HV, VH, VV);
- By combining interferometric and polarimetric acquisition modes;
- Stereo mode.

Obviously, different acquisition modes are subject to different processing techniques, namely:

- **Processing of SAR Intensity**
The product generation is based on the intensity processing.
- **Interferometric SAR (InSAR) Processing**
The product generation includes the interferometric phase processing.
- **Polarimetric SAR (PolSAR) Processing**
The product generation includes the polarimetric phase processing.
- **Polarimetric Interferometric SAR (PolInSAR) Processing**
The product generation includes polarimetric and interferometric phase processing.
- **SAR-stereo Processing**
The product generation is based on the processing of intensity stereo pair.

Modules

SARscape is a modular set of functions supporting the processing of spaceborne and airborne SAR data and all above mentioned techniques.

Basic

It includes a set of processing steps for intensity and coherence, e.g. multi-looking, coregistration, single- and multi-date speckle filtering, temporal feature extraction, geocoding, radiometric calibration and normalization, and mosaicing. This is complemented by a multi-purpose tool, which includes a wide range of functions – from image visualisation, to Digital Elevation Model import and interpolation, to cartographic and geodetic transforms. The basic module is complemented by:

- **Focusing**
It supports the focusing of ERS-1 and 2 SAR, JERS-1 SAR, ENVISAT ASAR and ALDS PALSAR-1 data.
- **Gamma and Gaussian Filtering**
It includes a whole family of SAR specific filters including single-date, multi-date, and polarimetric ones. They are particularly efficient to reduce speckle, while preserving the radar reflectivity, the textural properties and the spatial resolution, especially in strongly textured SAR images. Developed by Privateers.

Interferometry

It supports the processing of Interferometric SAR (2-pass interferometry, InSAR) and Differential Interferometric SAR (n-pass interferometry, DInSAR) data for the generation of Digital Elevation

sarmap – sarscape



the earth observation gateway

- Home
- Company
- Software
- Products & Services
- Capacity Building

Interferometry

It supports the processing of Interferometric SAR (2-pass Interferometry, InSAR) and Differential Interferometric SAR (n-pass Interferometry, DInSAR) data for the generation of Digital Elevation Model, Coherence, and Land Displacement maps. The interferometric module is complemented by:

- **ScanSAR Interferometry**
It offers the capabilities to process InSAR and DInSAR data over large areas (400 by 400 km).
- **SAR Polarimetry and Polarimetric Interferometry**
It supports the processing of polarimetric and polarimetric Interferometric SAR data.
- **Interferometric Stacking**
Based on Small Baseline Subset (SBS) and Persistent Scatterers (PS) techniques, this module enables to determine displacements of individual features.

SAR stereo

It supports the processing of stereo-SAR data for the generation of Digital Elevation Model.

Quality Assessment Tool

It includes a set of customized functions for the assessment of SAR data quality in geometric, radiometric, and polarimetric terms.

SARScape supports following **spaceborne** SAR sensors:

- ERS-1 and 2 SAR
- ERS-1 SAR
- RADARSAT-1 and 2
- ENVISAT ASAR
- ALOS PALSAR-1 and ALOS-2
- SAR Lupe
- TerraSAR-X and TanDEM-X
- COSMO-SkyMed
- RISAT-1
- KOMPSAT-5
- Sentinel-1
- PAZ

and following **airborne** SAR systems:

- OrbISAR-1 (X- and P-band)
- F-SAR (P, L, C, X-band)
- RAMSES (P, L, S, C, X, Ku, Ka, W-band)
- TELAEB (X-band)
- UAV SAR in Stanag format

Information

- [SARScape technical description \(2015\)](#)
- [SAR-Subbook \(1.0MB\)](#)

sarmap SA
Taschine di Sarnes 10
6009 Purzosen
Switzerland

phone +41 91 801 0385
sarmap@sarmap.ch

ENVISARscape



MY ACCOUNT • CONTACT US

Home

Products & Services

Industries

Learn

Support

Blog

Company

UK/English



ENVI ENVI Services Engine ENVI LiDAR ENVI SARscape ArcGIS

ENVI SARscape

ENVI SARscape® allows you to easily read, process, and output your SAR data so you can transform hard-to-interpret data into meaningful, contextual information. Synthetic Aperture Radar (SAR) data is a sophisticated data type that can be used to analyse an area of interest during the day or night, regardless of weather conditions. It is particularly helpful when trying to detect change and study the topography of a specific area.

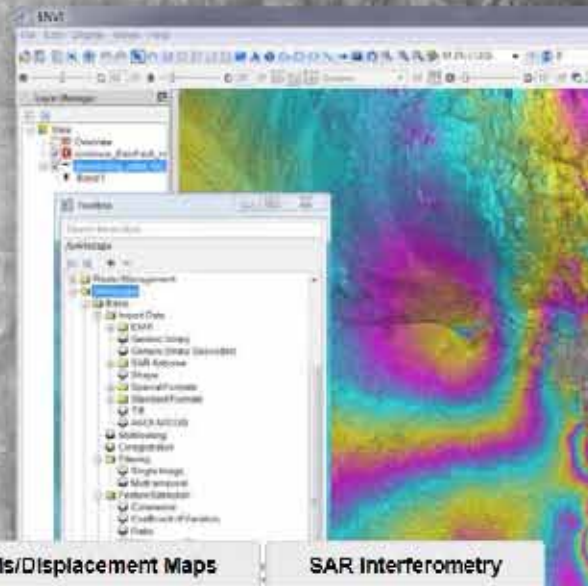

New In SARscape 5.1

SAR Processing

SAR Image Analysis

DEMs/Displacement Maps

SAR Interferometry



SAR Data Availability for Paphos Testsite

Ramon Brcic

MF-SAR



Knowledge for Tomorrow

Overview

- Checked data availability for 5 missions:
 - TerraSAR-X and TanDEM-X (DLR)
 - ERS and ENVISAT (ESA)
 - Sentinel-1 (ESA)
- For each mission, different products are available at different resolutions and at different times (next slide)
- Factors affecting decision:
 - Suitability of acquisition mode (resolution) for application (archaeology)
 - Availability of data for intended method of analysis
 - Historical / actual / future
 - InSAR pairs (monitoring changes and large movements) / stack (detailed surface deformation monitoring)



Sensor Resolution and Temporal Coverage

Satellite / Sensor / Mode	Ground Resolution [m]			Temporal Coverage
	Range	Azimuth	Cell [m ²]	
TSX ST: Staring Spotlight	1.3	0.24	0.31	2007 on
TSX HS: High Resolution Spotlight	1.3	1.1	1.4	
TSX SL: Spotlight	2.5	1.7	4.3	
TSX SM: Stripmap	2.6	3.3	8.6	
ERS Stripmap	25	4	100	1991 – 2001
ENVISAT Stripmap	16	4	64	2002 – 2012
Sentinel-1 TOPS	5.7	23	130	2014 on

Resolution are average values on ground

TSX: azimuth resolution for single polarisation

TSX ST, HS: ground range resolution for 300MHz



TerraSAR-X / TanDEM-X



Number of Scenes 4 (2 CoSSC Products)

EOWEB TDM SM ASC 24

The screenshot shows the EOWEB web interface. At the top, there is a navigation bar with 'Home', 'Logout', and 'Logout' buttons. Below that, there are tabs for 'Update the Data', 'Help', 'Data', 'EOWEB', and 'Search by Product'. The main area features a map of the Paphos Testsite with several green rectangular overlays representing SAR data scenes. On the left side, there is a 'Data List' panel with a tree view showing various data products, including 'TDM SM ASC 24'. Below the map, there is a table with columns for 'ID', 'Acq', 'Orbit', 'Top View', 'Mission Labels', 'Scene', 'Acq Date', 'Lvl', 'Scene Prio', 'Full Name', 'Status', 'Product Desc', 'Acquisition Wavelength', 'Location', 'Acquisition Date', 'Mission', 'Scene Number', 'Mission Label', 'Acquisition Date', 'Status', and 'Acq Date'. The table contains four rows of data.

ID	Acq	Orbit	Top View	Mission Labels	Scene	Acq Date	Lvl	Scene Prio	Full Name	Status	Product Desc	Acquisition Wavelength	Location	Acquisition Date	Mission	Scene Number	Mission Label	Acquisition Date	Status	Acq Date
1	ASC	ASC	ASC	ASC	ASC	2016-05-17 14:30:4	ASC	ASC	ASC	ASC	ASC	ASC	ASC	ASC	ASC	ASC	ASC	ASC	ASC	ASC
2	ASC	ASC	ASC	ASC	ASC	2016-05-17 14:30:4	ASC	ASC	ASC	ASC	ASC	ASC	ASC	ASC	ASC	ASC	ASC	ASC	ASC	ASC
3	ASC	ASC	ASC	ASC	ASC	2016-05-17 14:30:4	ASC	ASC	ASC	ASC	ASC	ASC	ASC	ASC	ASC	ASC	ASC	ASC	ASC	ASC
4	ASC	ASC	ASC	ASC	ASC	2016-05-17 14:30:4	ASC	ASC	ASC	ASC	ASC	ASC	ASC	ASC	ASC	ASC	ASC	ASC	ASC	ASC



Number of Scenes 4 (2 CoSSC Products)

EOWEB TDM SM DES 1

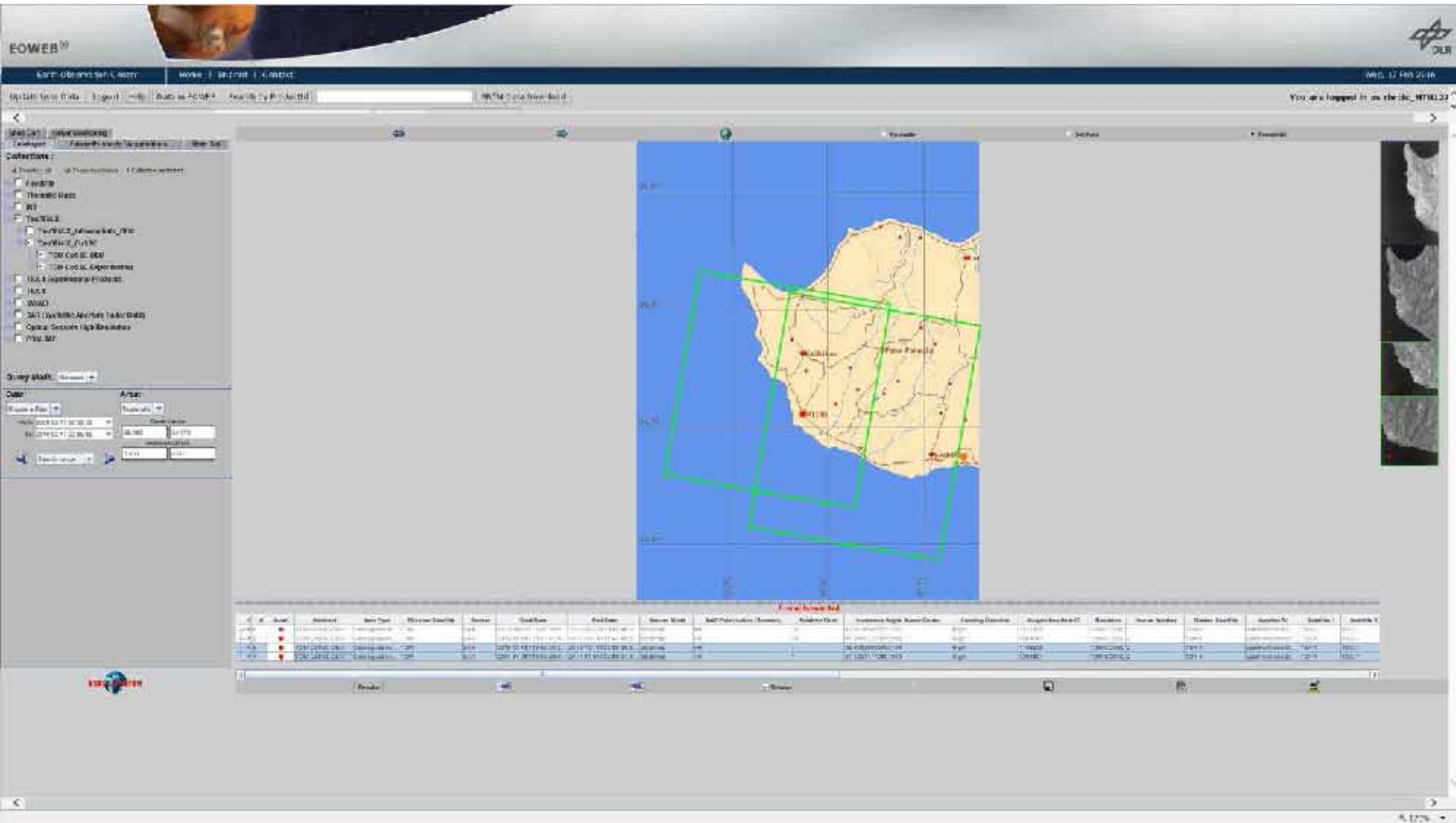

EOWEB ST Future

Legend

- SAR-T SAR-T Future scores
- SAR-T SAR-T SAR-T Future scores
- SAR-T SAR-T SAR-T Future scores
- SAR-T SAR-T SAR-T Future scores
- SAR-T SAR-T SAR-T Future scores

Acquisition Window: Region of Interest:

Start: 20160522 00:00:00
End: 20160522 23:59:59

Acquisition Details

ID	Status	Address	Start Date	End Date	Acquisition Mode	Sensor Mode	Polarization	Resolution	Swath Width	Swath Angle	Swath Direction	Swath Position	Swath Orientation	Swath Frequency	Swath Wavelength	Swath Bandwidth	Swath Center Frequency	Swath Bandwidth
1	Success	SAR-T SAR-T SAR-T Future scores	20160522 00:00:00	20160522 23:59:59	SAR-T SAR-T SAR-T Future scores	SAR-T SAR-T SAR-T Future scores	SAR-T SAR-T SAR-T Future scores	SAR-T SAR-T SAR-T Future scores	SAR-T SAR-T SAR-T Future scores	SAR-T SAR-T SAR-T Future scores	SAR-T SAR-T SAR-T Future scores	SAR-T SAR-T SAR-T Future scores	SAR-T SAR-T SAR-T Future scores	SAR-T SAR-T SAR-T Future scores	SAR-T SAR-T SAR-T Future scores	SAR-T SAR-T SAR-T Future scores	SAR-T SAR-T SAR-T Future scores	SAR-T SAR-T SAR-T Future scores
2	Success	SAR-T SAR-T SAR-T Future scores	20160522 00:00:00	20160522 23:59:59	SAR-T SAR-T SAR-T Future scores	SAR-T SAR-T SAR-T Future scores	SAR-T SAR-T SAR-T Future scores	SAR-T SAR-T SAR-T Future scores	SAR-T SAR-T SAR-T Future scores	SAR-T SAR-T SAR-T Future scores	SAR-T SAR-T SAR-T Future scores	SAR-T SAR-T SAR-T Future scores	SAR-T SAR-T SAR-T Future scores	SAR-T SAR-T SAR-T Future scores	SAR-T SAR-T SAR-T Future scores	SAR-T SAR-T SAR-T Future scores	SAR-T SAR-T SAR-T Future scores	SAR-T SAR-T SAR-T Future scores
3	Success	SAR-T SAR-T SAR-T Future scores	20160522 00:00:00	20160522 23:59:59	SAR-T SAR-T SAR-T Future scores	SAR-T SAR-T SAR-T Future scores	SAR-T SAR-T SAR-T Future scores	SAR-T SAR-T SAR-T Future scores	SAR-T SAR-T SAR-T Future scores	SAR-T SAR-T SAR-T Future scores	SAR-T SAR-T SAR-T Future scores	SAR-T SAR-T SAR-T Future scores	SAR-T SAR-T SAR-T Future scores	SAR-T SAR-T SAR-T Future scores	SAR-T SAR-T SAR-T Future scores	SAR-T SAR-T SAR-T Future scores	SAR-T SAR-T SAR-T Future scores	SAR-T SAR-T SAR-T Future scores
4	Success	SAR-T SAR-T SAR-T Future scores	20160522 00:00:00	20160522 23:59:59	SAR-T SAR-T SAR-T Future scores	SAR-T SAR-T SAR-T Future scores	SAR-T SAR-T SAR-T Future scores	SAR-T SAR-T SAR-T Future scores	SAR-T SAR-T SAR-T Future scores	SAR-T SAR-T SAR-T Future scores	SAR-T SAR-T SAR-T Future scores	SAR-T SAR-T SAR-T Future scores	SAR-T SAR-T SAR-T Future scores	SAR-T SAR-T SAR-T Future scores	SAR-T SAR-T SAR-T Future scores	SAR-T SAR-T SAR-T Future scores	SAR-T SAR-T SAR-T Future scores	SAR-T SAR-T SAR-T Future scores



EOWEB HS Future

EOWEB^{HS} Future

Karte: Oceansat-2A, Höhe: 1, Einheit: Kilometr, WGS, 17 Feb 2016

Acquisition Hinweis: Regions of Interest

Acquisition Criteria:

ID	Sub-ID	Mission	Modus	Startzeit	Endzeit	Ordnung	Flughöhe (m)	Start-Ordnung	Stop-Ordnung	Swath	Full Swath (km)	Range	Full Swath (km)	Range	Swath (km)	Range	Swath (km)	Range	Swath (km)	Range	Swath (km)	Range	Swath (km)	Range	Swath (km)	Range	Swath (km)	Range	
1	1	SAR 1	Full Swath	2016-02-16 08:30:00	2016-02-16 08:30:00	1	1000	1	1	1000	1000	1000	1000	1000	1000	1000	1000	1000	1000	1000	1000	1000	1000	1000	1000	1000	1000	1000	1000
2	2	SAR 2	Full Swath	2016-02-16 08:30:00	2016-02-16 08:30:00	2	1000	2	2	1000	1000	1000	1000	1000	1000	1000	1000	1000	1000	1000	1000	1000	1000	1000	1000	1000	1000	1000	1000
3	3	SAR 3	Full Swath	2016-02-16 08:30:00	2016-02-16 08:30:00	3	1000	3	3	1000	1000	1000	1000	1000	1000	1000	1000	1000	1000	1000	1000	1000	1000	1000	1000	1000	1000	1000	1000



EOWEB SL Future

The screenshot shows the EOWEB SL Future web interface. At the top, there's a navigation bar with "Home", "About", and "Contact" links. Below that, a search bar and a "Home" button are visible. The main area features a map of the Paphos test site with a red polygon overlay. To the left of the map, there are several panels: "Acquisition History" with a search bar, "Region of Interest" with a map view, and "Acquisition Criteria" with a table of parameters. Below the map, there is a table with columns for "id", "Status", "Applied", "Item type", "Start/End", "Baseline", "Product type", "Acquisition mode", "Start date", "Stop date", "Name", "Sub Pixel Size (m)", "Angle", "Aperture Size (m)", "Polarization", "Looking direction", "Swath width", "Swath cover", "Start Cycle Number", "End Cycle Number", and "File Name".

id	Status	Applied	Item type	Start/End	Baseline	Product type	Acquisition mode	Start date	Stop date	Name	Sub Pixel Size (m)	Angle	Aperture Size (m)	Polarization	Looking direction	Swath width	Swath cover	Start Cycle Number	End Cycle Number	File Name
1	Success	10/11/2016 10:00:00	Point cloud	10/11/2016 10:00:00	10/11/2016 10:00:00	Point cloud	Single	10/11/2016 10:00:00	10/11/2016 10:00:00	10/11/2016 10:00:00	10/11/2016 10:00:00	10/11/2016 10:00:00	10/11/2016 10:00:00	10/11/2016 10:00:00	10/11/2016 10:00:00	10/11/2016 10:00:00	10/11/2016 10:00:00	10/11/2016 10:00:00	10/11/2016 10:00:00	10/11/2016 10:00:00
2	Success	10/11/2016 10:00:00	Point cloud	10/11/2016 10:00:00	10/11/2016 10:00:00	Point cloud	Single	10/11/2016 10:00:00	10/11/2016 10:00:00	10/11/2016 10:00:00	10/11/2016 10:00:00	10/11/2016 10:00:00	10/11/2016 10:00:00	10/11/2016 10:00:00	10/11/2016 10:00:00	10/11/2016 10:00:00	10/11/2016 10:00:00	10/11/2016 10:00:00	10/11/2016 10:00:00	10/11/2016 10:00:00
3	Success	10/11/2016 10:00:00	Point cloud	10/11/2016 10:00:00	10/11/2016 10:00:00	Point cloud	Single	10/11/2016 10:00:00	10/11/2016 10:00:00	10/11/2016 10:00:00	10/11/2016 10:00:00	10/11/2016 10:00:00	10/11/2016 10:00:00	10/11/2016 10:00:00	10/11/2016 10:00:00	10/11/2016 10:00:00	10/11/2016 10:00:00	10/11/2016 10:00:00	10/11/2016 10:00:00	10/11/2016 10:00:00
4	Success	10/11/2016 10:00:00	Point cloud	10/11/2016 10:00:00	10/11/2016 10:00:00	Point cloud	Single	10/11/2016 10:00:00	10/11/2016 10:00:00	10/11/2016 10:00:00	10/11/2016 10:00:00	10/11/2016 10:00:00	10/11/2016 10:00:00	10/11/2016 10:00:00	10/11/2016 10:00:00	10/11/2016 10:00:00	10/11/2016 10:00:00	10/11/2016 10:00:00	10/11/2016 10:00:00	10/11/2016 10:00:00
5	Success	10/11/2016 10:00:00	Point cloud	10/11/2016 10:00:00	10/11/2016 10:00:00	Point cloud	Single	10/11/2016 10:00:00	10/11/2016 10:00:00	10/11/2016 10:00:00	10/11/2016 10:00:00	10/11/2016 10:00:00	10/11/2016 10:00:00	10/11/2016 10:00:00	10/11/2016 10:00:00	10/11/2016 10:00:00	10/11/2016 10:00:00	10/11/2016 10:00:00	10/11/2016 10:00:00	10/11/2016 10:00:00



Spotlight Products (SL, HS, ST)

- No existing data over Cyprus
- [TerraSAR-X Science Server System](#)
 - Ordering of new spotlight (SL, HS, ST) products possible through “General Proposal Submission”: [TSX-Science-Plan.pdf](#)
 - Ordering of all archived TerraSAR-X products (older than 18 months) possible through “AO for Utilization of the TerraSAR-X Archive”: [TSX-Archived-Data-2014-AO-1.1.pdf](#)



EOWEB HS ST Current

The screenshot shows the EOWEB web interface. At the top, there's a navigation bar with 'Home', 'Help', and 'Logout'. Below that, a search bar and a 'Search by Product' dropdown are visible. The main area features a map of the Paphos Testsite with several red and green rectangular overlays representing SAR data footprints. To the left of the map is a sidebar with a tree view of data collections, including 'TSX-1 SAR L1b Staring Spotlight' and 'TSX-1 SAR L1b High Resolution Spotlight'. Below the map is a table with columns for 'Id', 'Avail.', 'Abstract', 'Item Type', 'Mission/Satellite', 'Sensor', 'Start Date', 'End Date', and 'Sensor Mode'. The table lists 10 data items, all with 'Avail.' status '●' and 'Sensor Mode' 'StaringSpotlight' or 'HighResSpotlight'.

↑	Id	Avail.	Abstract	Item Type	Mission/Satellite	Sensor	Start Date	End Date	Sensor Mode
*	1	●	TSX-1.SAR.L1b-Staring-Spotlight	CatalogueSce...	TSX-1	SAR	2016-04-18T15:39:27,1...	2016-04-18T15:39:27,5...	StaringSpotlight
-	2	●	TSX-1.SAR.L1b-Staring-Spotlight	CatalogueSce...	TSX-1	SAR	2016-04-22T03:55:44,6...	2016-04-22T03:55:45,1...	StaringSpotlight
-	3	●	TSX-1.SAR.L1b-Staring-Spotlight	CatalogueSce...	TSX-1	SAR	2016-04-23T15:47:59,7...	2016-04-23T15:48:00,1...	StaringSpotlight
-	4	●	TSX-1.SAR.L1b-Staring-Spotlight	CatalogueSce...	TSX-1	SAR	2016-04-29T15:39:27,2...	2016-04-29T15:39:27,6...	StaringSpotlight
-	5	●	TSX-1.SAR.L1b-Staring-Spotlight	CatalogueSce...	TSX-1	SAR	2016-05-03T03:55:45,0...	2016-05-03T03:55:45,4...	StaringSpotlight
-	6	●	TSX-1.SAR.L1b-Staring-Spotlight	CatalogueSce...	TSX-1	SAR	2016-05-04T15:48:00,2...	2016-05-04T15:48:00,7...	StaringSpotlight
-	7	●	TSX-1.SAR.L1b-High-Resolution-Spotli...	CatalogueSce...	TSX-1	SAR	2016-04-17T03:47:11,2...	2016-04-17T03:47:11,9...	HighResSpotlight
-	8	●	TSX-1.SAR.L1b-High-Resolution-Spotli...	CatalogueSce...	TSX-1	SAR	2016-04-17T15:56:32,3...	2016-04-17T15:56:33,1...	HighResSpotlight
-	9	●	TSX-1.SAR.L1b-High-Resolution-Spotli...	CatalogueSce...	TSX-1	SAR	2016-04-28T03:47:11,4...	2016-04-28T03:47:12,1...	HighResSpotlight
*	10	●	TSX-1.SAR.L1b-High-Resolution-Spotli...	CatalogueSce...	TSX-1	SAR	2016-04-28T15:56:32,5...	2016-04-28T15:56:33,2...	HighResSpotlight



ERS / ENVISAT



EOLi ERS ENVISAT Overview

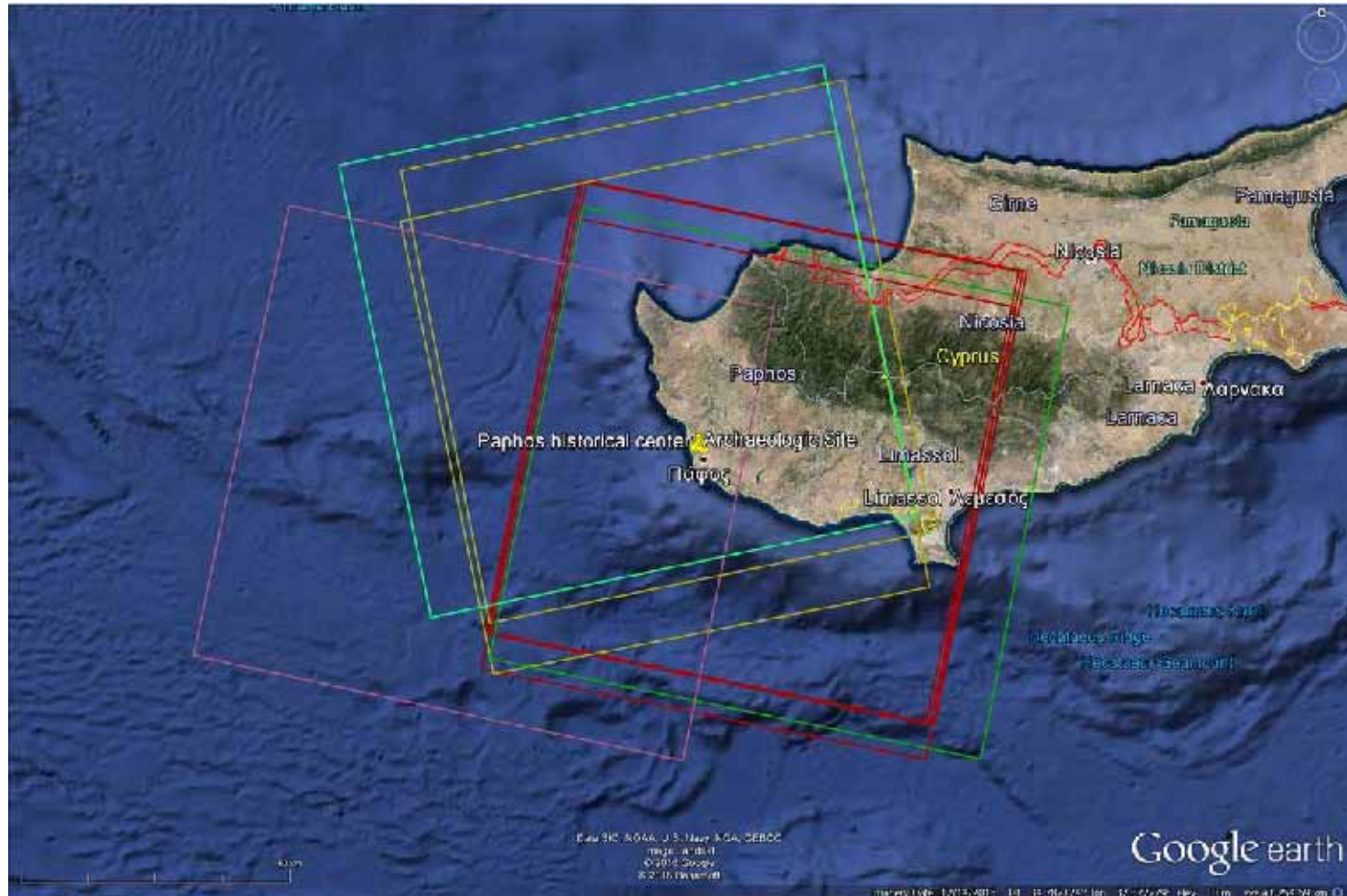



EOLi ERS ASC 386

Number of Scenes	10
Start Date	04.03.1993
End Date	26.11.2000
Days	2824
Years	7.73

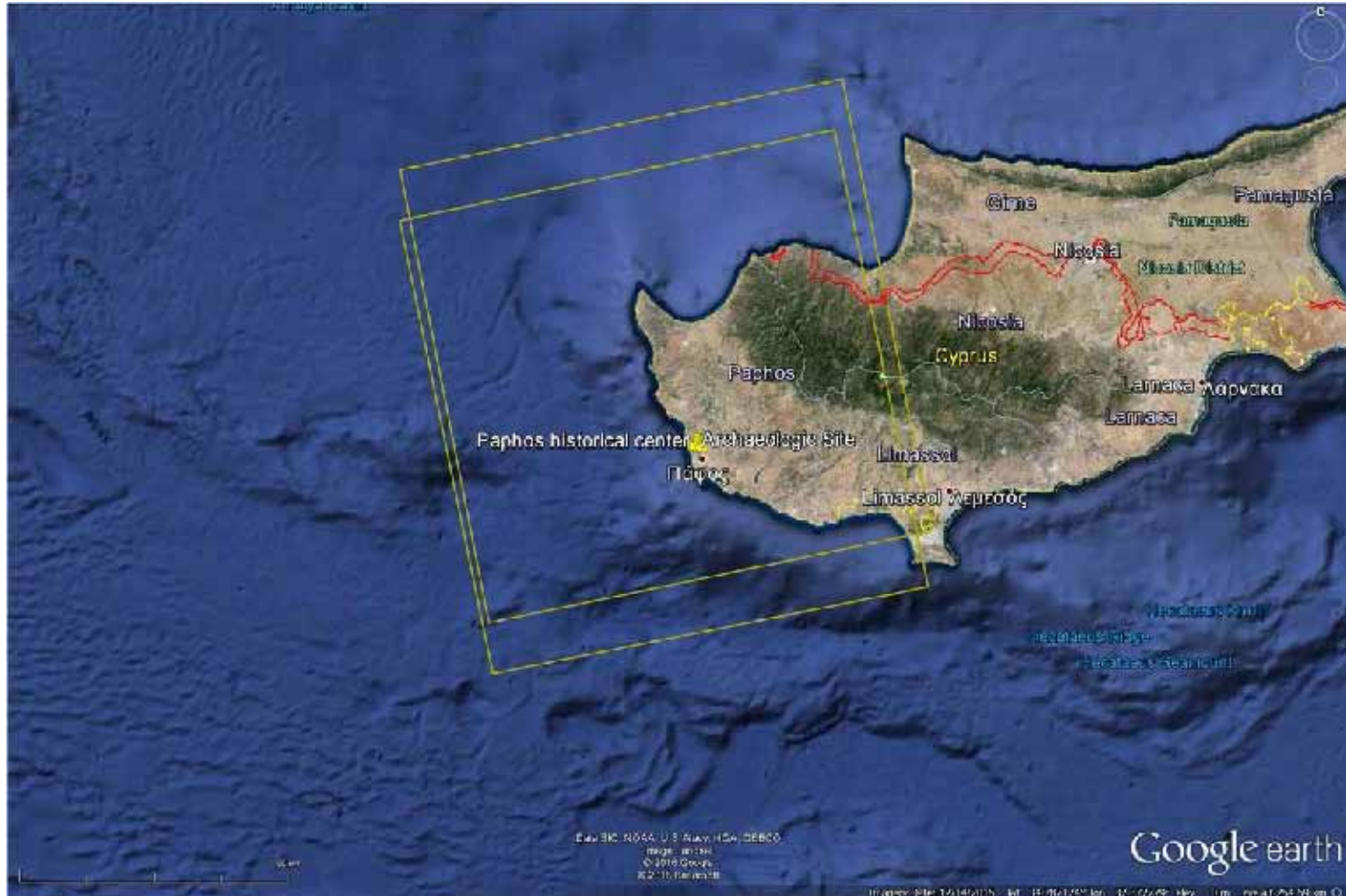



EOLiERS DES 436

Number of Scenes	38
Start Date	01.06.1992
End Date	04.01.2001
Days	3139
Years	8.59





EOLi ENVISAT ASC 386

Number of Scenes	14
Start Date	01.12.2002
End Date	09.03.2008
Days	1925
Years	5.27

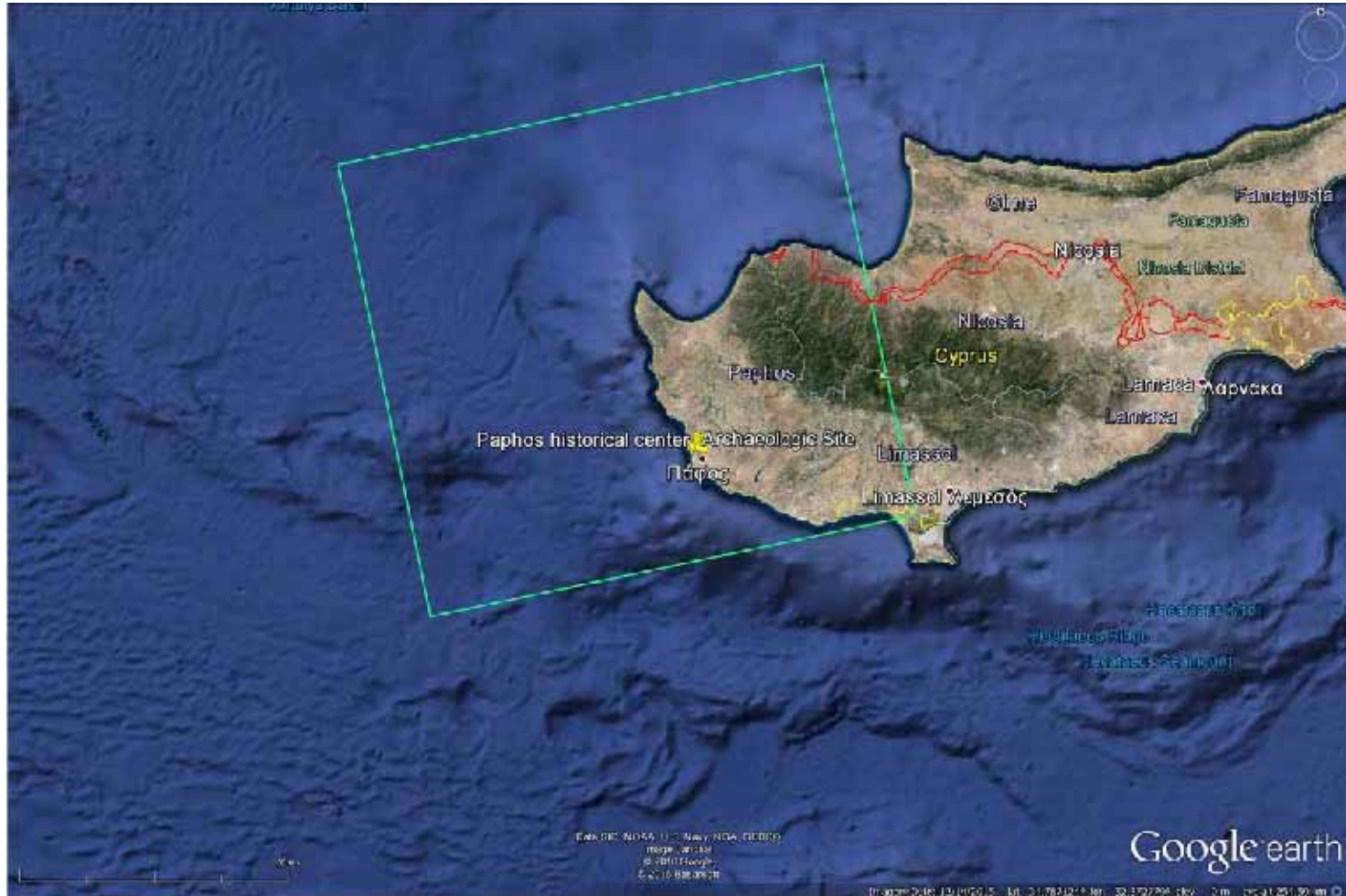



EOLi ENVISAT DES 207

Number of Scenes	35
Start Date	13.01.2004
End Date	28.09.2010
Days	2450
Years	6.71

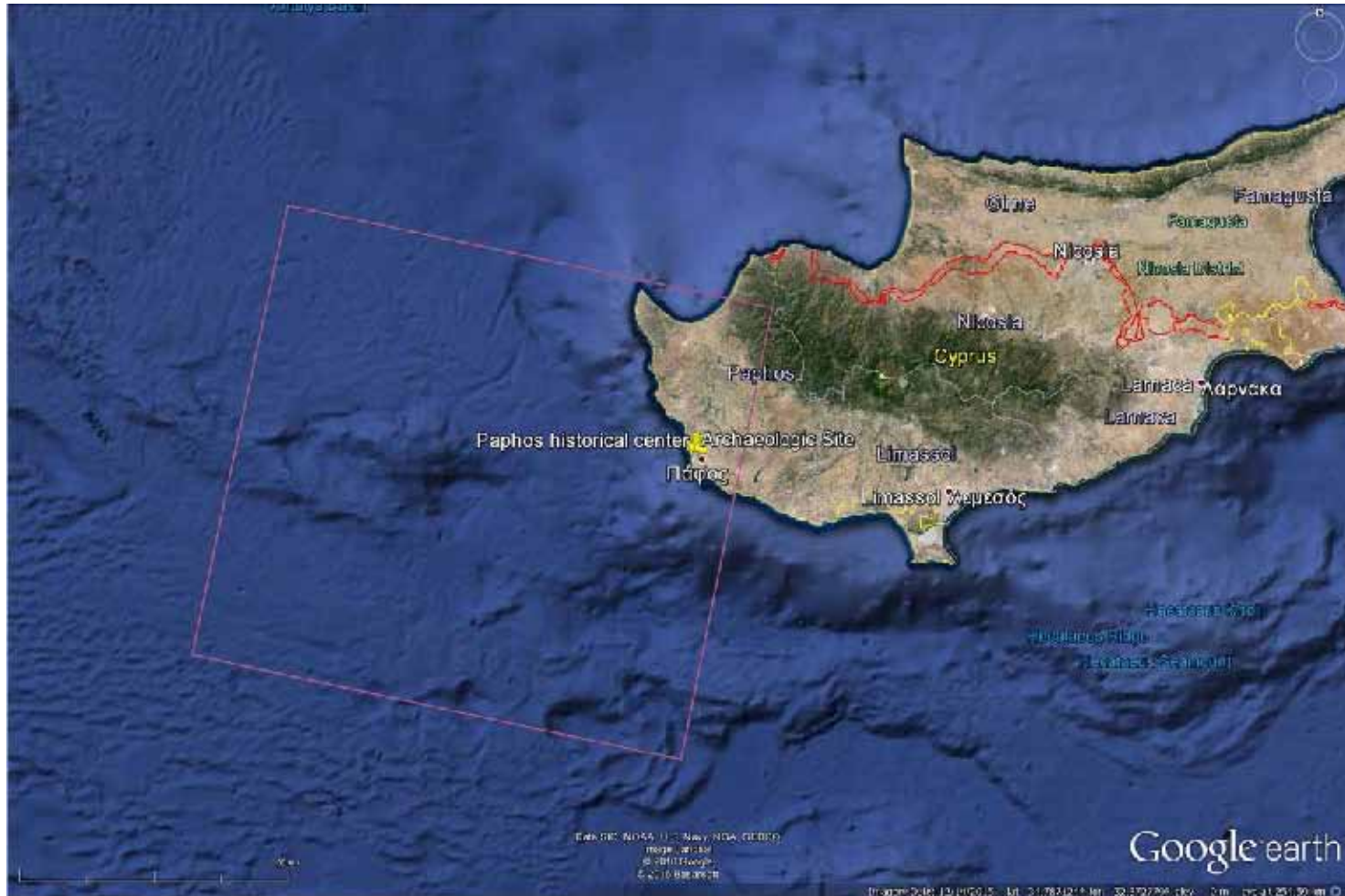



EOLi ENVISAT DES 436

Number of Scenes	36
Start Date	03.07.2003
End Date	14.10.2010
Days	2660
Years	7.28



Suggestion

- Order
 - ERS DES 436 (38 Scenes, 1992 – 2001)
 - ENVISAT DES 436 (36 Scenes, 2003 – 2010)
- PSI possible on these stacks (20 – 30 scene minimum)
- Historical analysis for determining baseline for deformation monitoring over previous 2 decades



Sentinel-1



SciHub S1 ASC 160

Number of Scenes	37
Start Date	16.10.2014
End Date	08.02.2016
Days	481
Cycles	40

18.05.2016
47 scenes

The screenshot displays the Sentinel Scientific Data Hub interface. On the right, a map shows the Paphos Testsite area in Cyprus, highlighted with a red overlay. On the left, a list of SAR data products is visible, including details such as scene ID, acquisition date, and processing status. The interface includes search bars, navigation controls, and a 'CLOSE' button at the bottom.

© ESA – European Space Agency



SciHub S1 DES 167

Number of Scenes	34
Start Date	17.10.2014
End Date	28.01.2016
Days	469
Cycles	39

18.05.2016
50 scenes

The screenshot displays the Sentinel Scientific Data Hub interface. On the left, a list of SAR scenes is shown, each with a thumbnail and metadata. The main area is a map of the Paphos Testsite, with a red polygon highlighting the area of interest. The map includes labels for 'Antalya' and 'Paphos'. The interface also features a search bar at the top, navigation controls on the right, and a 'CLOSE' button at the bottom left.

© ESA – European Space Agency



Sentinel-1

- Resolution low but ...
- European Earth observation programme Copernicus that includes the Sentinel series of satellites represent a 20 year plan
- Continuous and fixed acquisition plan over the EU /EEC
 - 1 ascending and 1 descending acquisition every 12 days with S-1A
 - 30 images / year / stack
 - 1 ascending and 1 descending acquisition every 6 days with S-1A/B
 - 60 images / year / stack
- Ideal for reliable long-term monitoring → PSI for deformation monitoring



Athena Summer School – SAR Data Evaluation

Ramon Brcic

MF-SAR



Knowledge for Tomorrow

Contents

- TerraSAR-X
- TanDEM-X
- Sentinel-1
- ERS



TerraSAR-X – HR and ST

Description	Sensor Mode	Orbit	Beam	Incidence Angle	Pass Direction	Acquisition Times	Temporal Baseline (days)	Effective Baseline (m)	Height of Ambiguity (m)	Ground Resolution (m)
HR	HighResSpotlight	100	spot_093R	53.1	Ascending	17.04.2016 28.04.2016	11	-	-	2.8
HR	HighResSpotlight	92	spot_086R	51.1	Descending	17.04.2016 28.04.2016	11	-	-	2.8
NeaPaphos ST	StaringSpotlight	115	spot_016R	23.6	Ascending	18.04.2016 29.04.2016	11	63.1	55.2	5 (LR), 2(MR), 1(HR)
NeaPaphos ST	StaringSpotlight	1	spot_047R	38.1	Descending	22.04.2016 03.05.2016	11	66.2	92.0	4 (LR), 2(MR), 1(HR)
TombOfTheKings ST	StaringSpotlight	24	spot_054R	40.9	Ascending	23.04.2016 04.05.2016	11	5.7	1181.2	4 (LR), 2(MR), 1(HR)



TerraSAR-X – Footprints

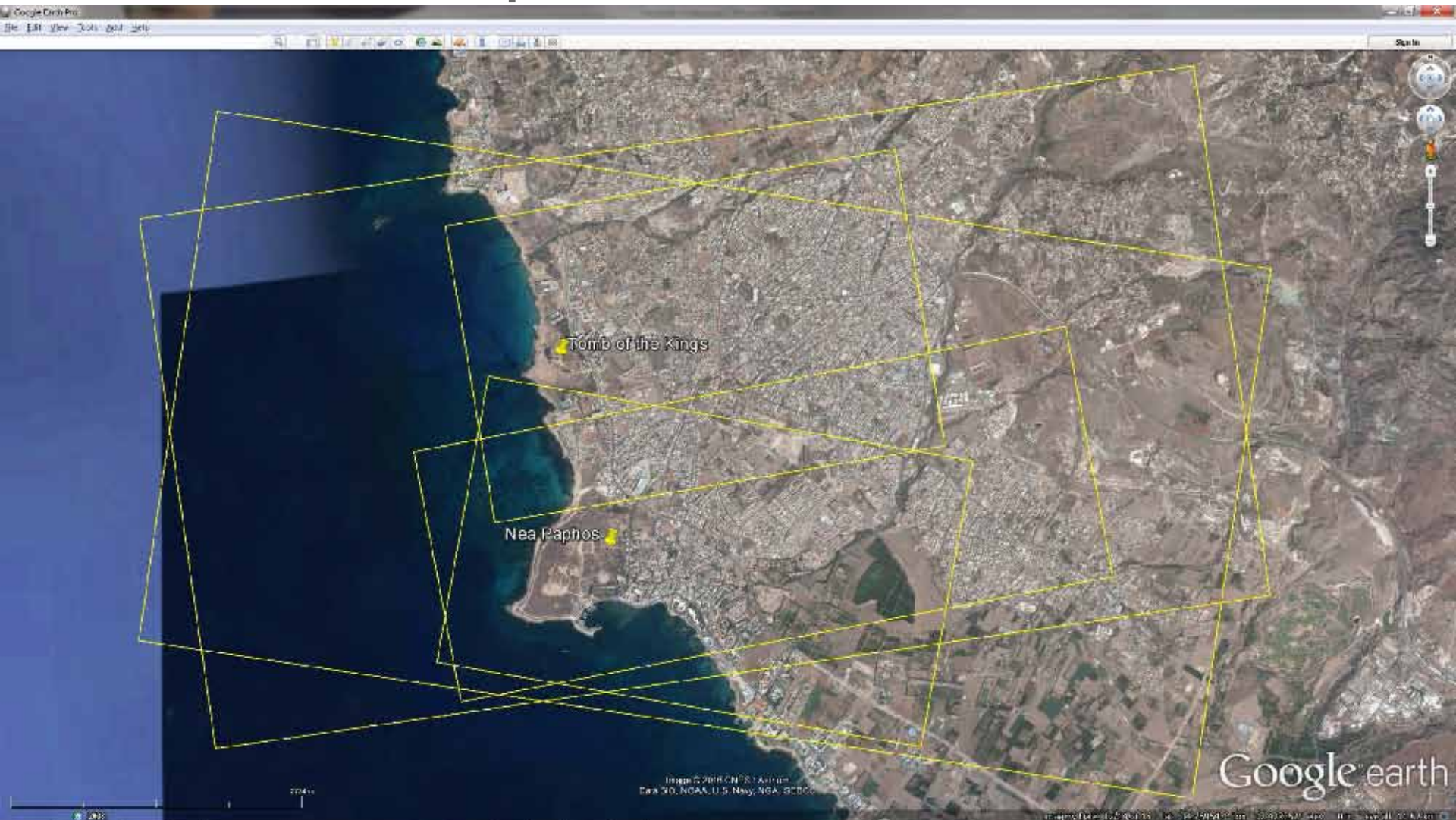

TerraSAR-X – HR (EEC), Directory Structure

- Data as downloaded from EOWEB
 - dims_op_oc_dfd2_513299430_1 holds acquisitions from 17.04.2016
 - dims_op_oc_dfd2_513308080_1 holds acquisitions from 28.04.2016

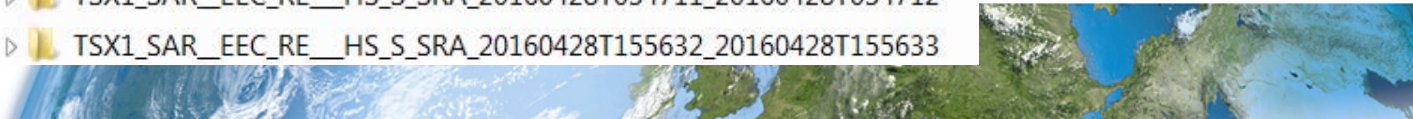

TerraSAR-X – HR (EEC) in QGIS

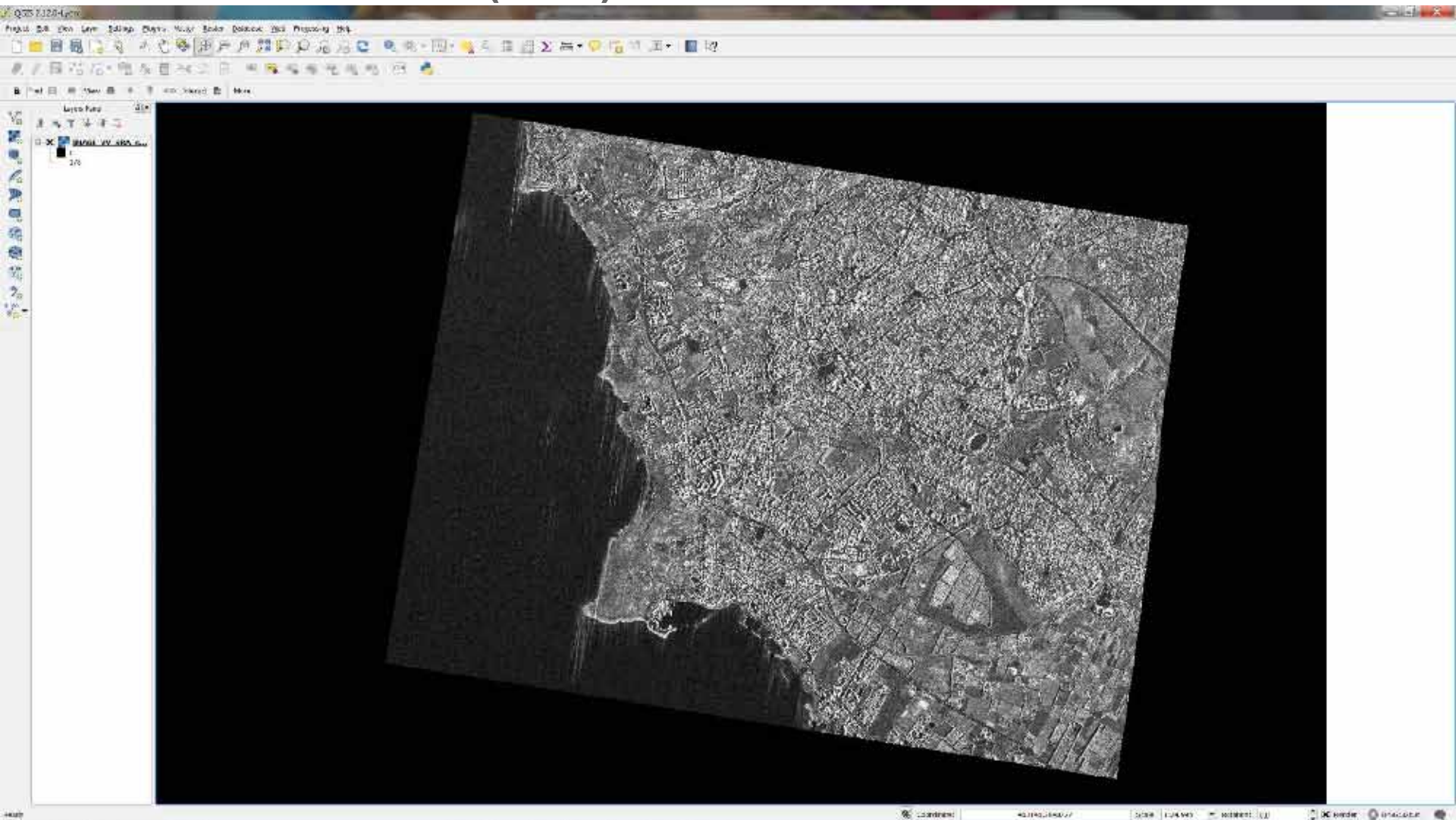









DLR



TerraSAR-X – ST (SSC)

- Naming scheme: $\{mode_testsite_relativeOrbitpassDirection_resolution\}.tgz$

 ST_NeaPaphos_001D_HR.tgz
 ST_NeaPaphos_001D_LR.tgz
 ST_NeaPaphos_001D_MR.tgz
 ST_NeaPaphos_115A_HR.tgz
 ST_NeaPaphos_115A_LR.tgz
 ST_NeaPaphos_115A_MR.tgz
 ST_TombOfTheKings_024A_HR.tgz
 ST_TombOfTheKings_024A_LR.tgz
 ST_TombOfTheKings_024A_MR.tgz



TerraSAR-X – ST (SSC), Directory Structure

- In-house processing! Unpack, go to subdirectory “exporthdir”

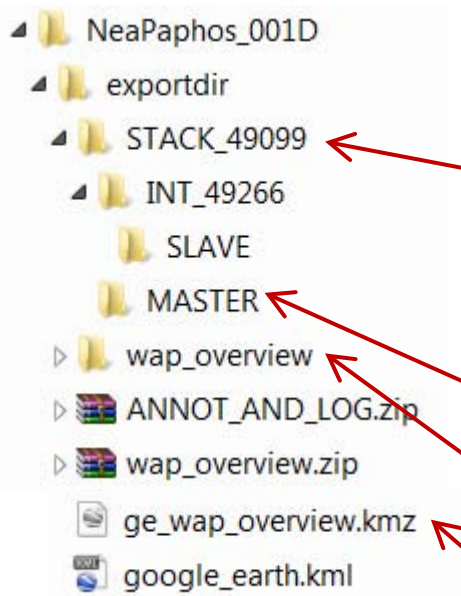

- GEO_AMPL_CAL_QL.tiff Slave calibrated amplitude and interferometric results as GeoTIFF (also in radar geometry as .ras)
- GEO_AMPL_CHANGE.tiff
- GEO_COH_AMPL.tiff
- GEO_COHER.tiff
- GEO_DCOHER.tiff
- GEO_DPHASE.tiff
- GEO_PHASE.tiff

Master calibrated amplitude as GeoTIFF (also in radar geometry as .ras)

HTML overview “wap_visualization.html”

Google Earth overview of GeoTIFFs

Quicker to view GeoTIFFs in QGIS as GE must first create superoverlay due to image size



wap_visualization.html

1. STACK INFO

2. MASTER SCENE

3. INTERFEROGRAMS

STACK INFORMATION

PARAMETERS			ORDERING
SENSOR	TSX	TYPE	IWAP-INSAR
IMAGING MODE	ST	NAME	ATHENA
BEAM ID	spot_047	ID	ST_NEAPAPHOS_001D
POLARIZATION	VV	ITEM ID	INSAR PROCESSING
NUMBER INTERFEROGRAMS	1		

GEOGRAPHICAL LOCATION



product type : STACK
 sensor : TSX
 acquisition mode / beam / pol : ST / spot_047 / VV
 master orb. / number Interf. : 49099 / 1

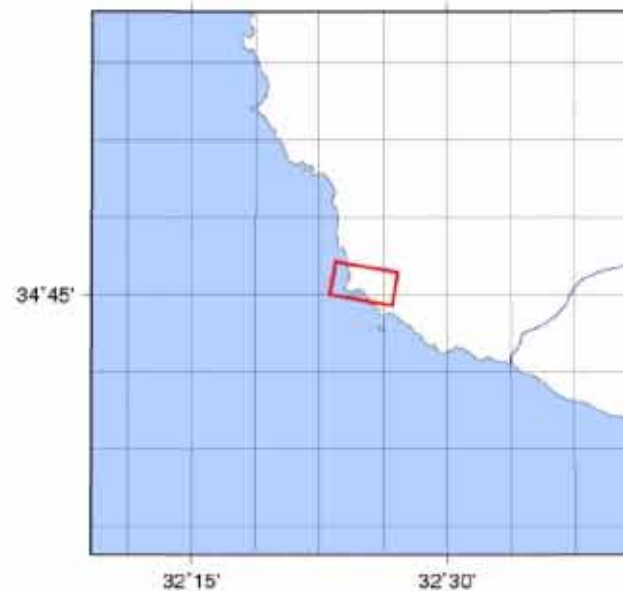

DLR



wap_visualization.html

TIME-BASELINE DISTRIBUTION

TIME-DOPPLER DISTRIBUTION

Time vs. Effective Baseline

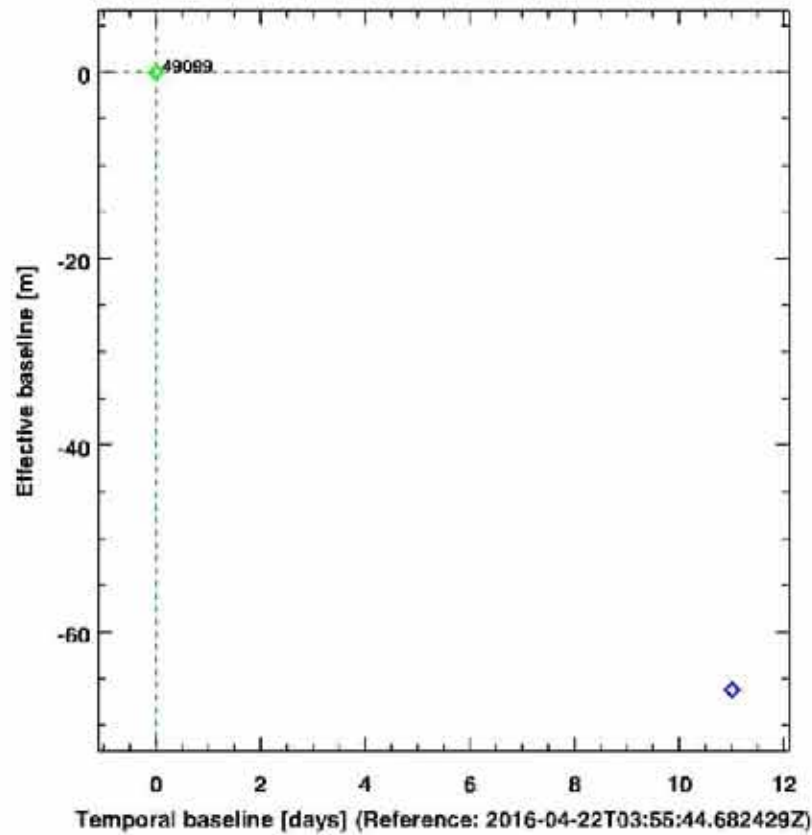

Time vs. Doppler

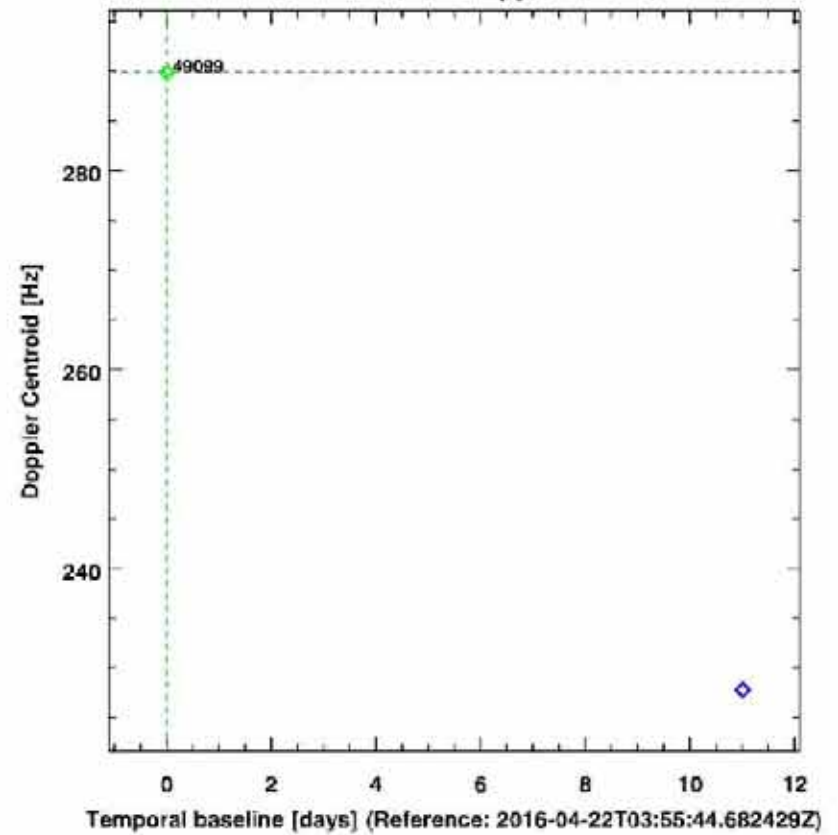

wap_visualization.html

MASTER SCENE

AMPLITUDE

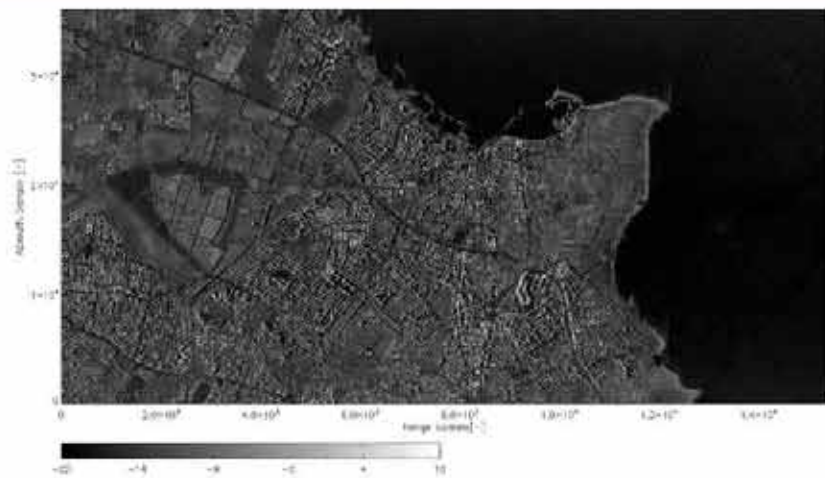

DEM & COREGISTRATION PS

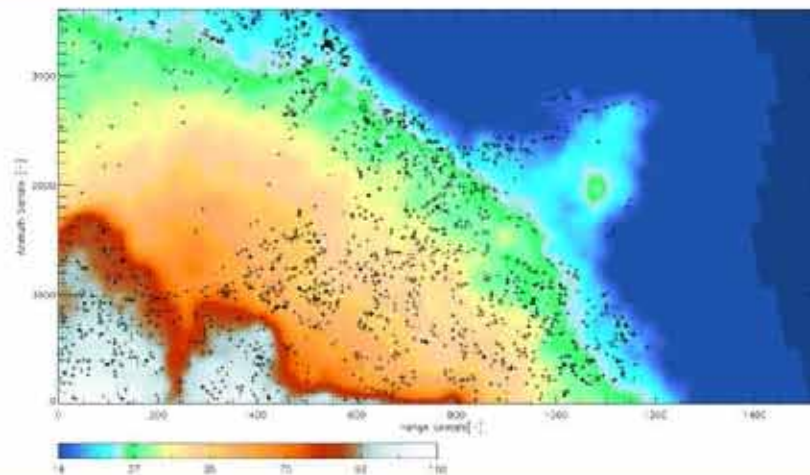

PARAMETERS

SENSOR	TSX-1
ORBIT NUMBER	49099
ORBIT TYPE	SCIE
ACQUISITION DATE	2015-04-22T03:55:44
DOPPLER	-1327.2 Hz

INTERFEROGRAMS

SLAVE ORBIT

INT_49256	
SENSOR	TSX-1
ORBIT NUMBER	49256
ORBIT TYPE	SCIE
ACQUISITION DATE	2015-05-03T03:55:45
TIME BASELINE	11
DOPPLER	-1358.1 Hz
EFF. BASELINE	66.2 m
HEIGHT OF ANTI.	92.0 m

DIFFERENTIAL PHASE

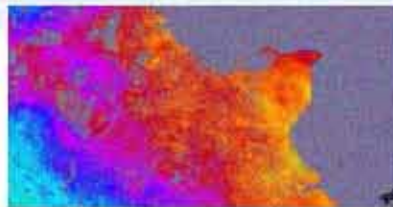

DIFFERENTIAL COHERENCE



AMPLITUDE COMPOSITE



ge_wap_overview.kmz

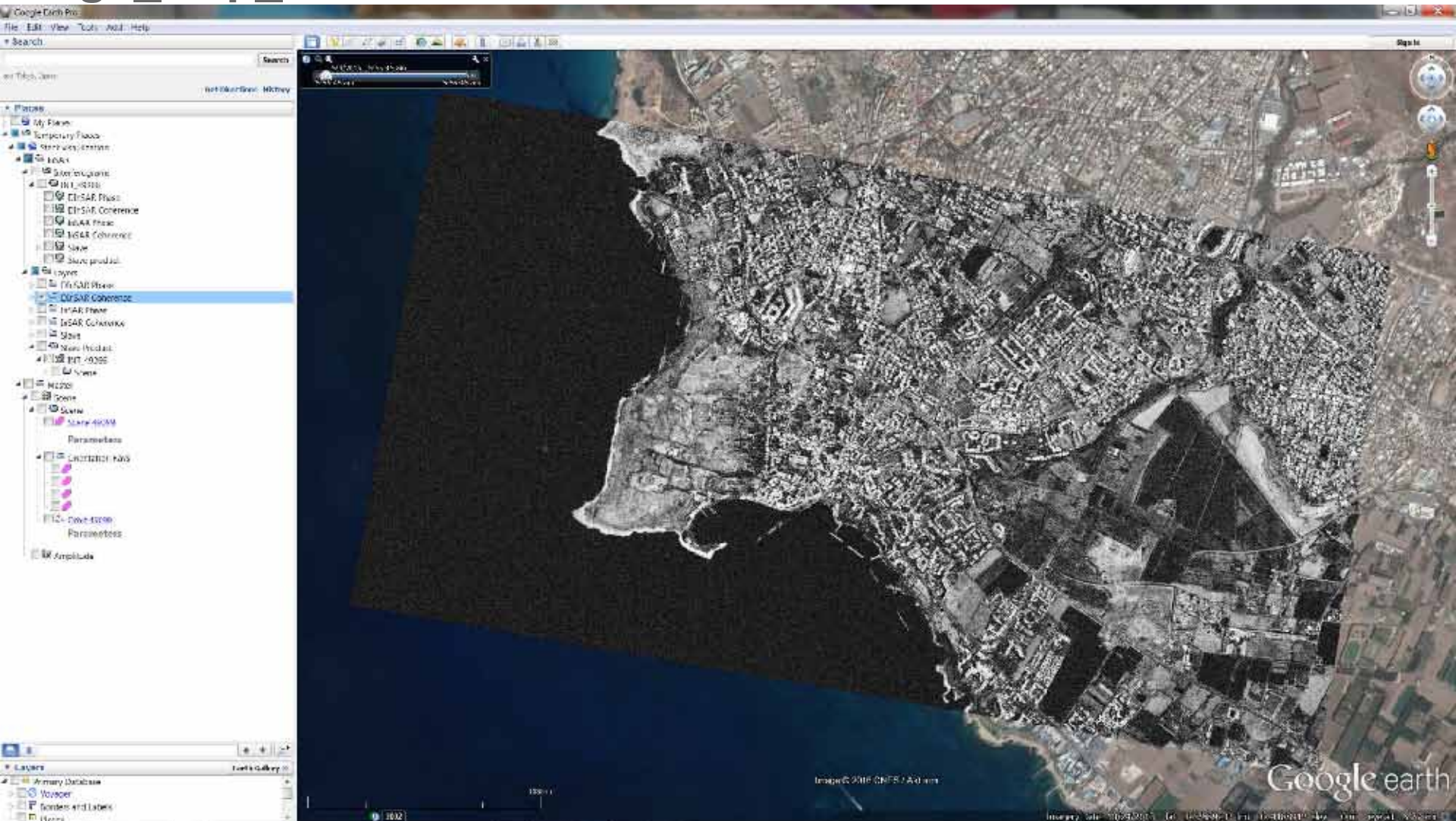

DLR



ge_wap_overview.kmz

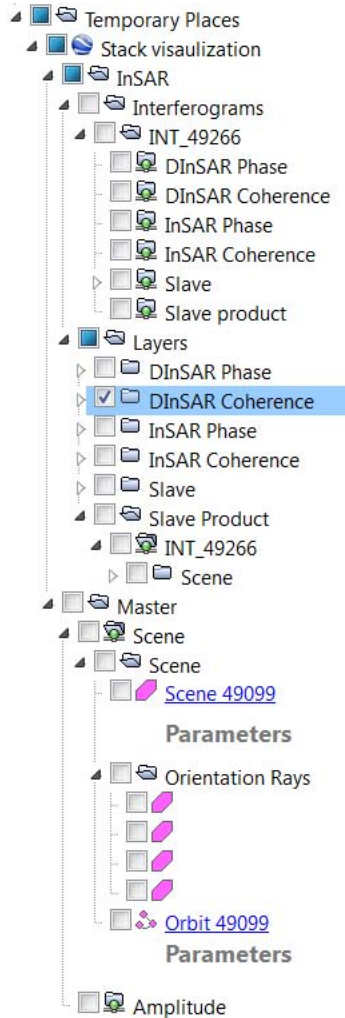

- InSAR: Ellipsoid corrected coherence and phase
- DInSAR: Terrain corrected coherence and phase
- Master and Slave: Calibrated amplitude (Sigma0)
- Scene: Scene bounding box (footprint) plus orientation rays joining orbit and bounding box



Coherence Amplitude Composite in QGIS

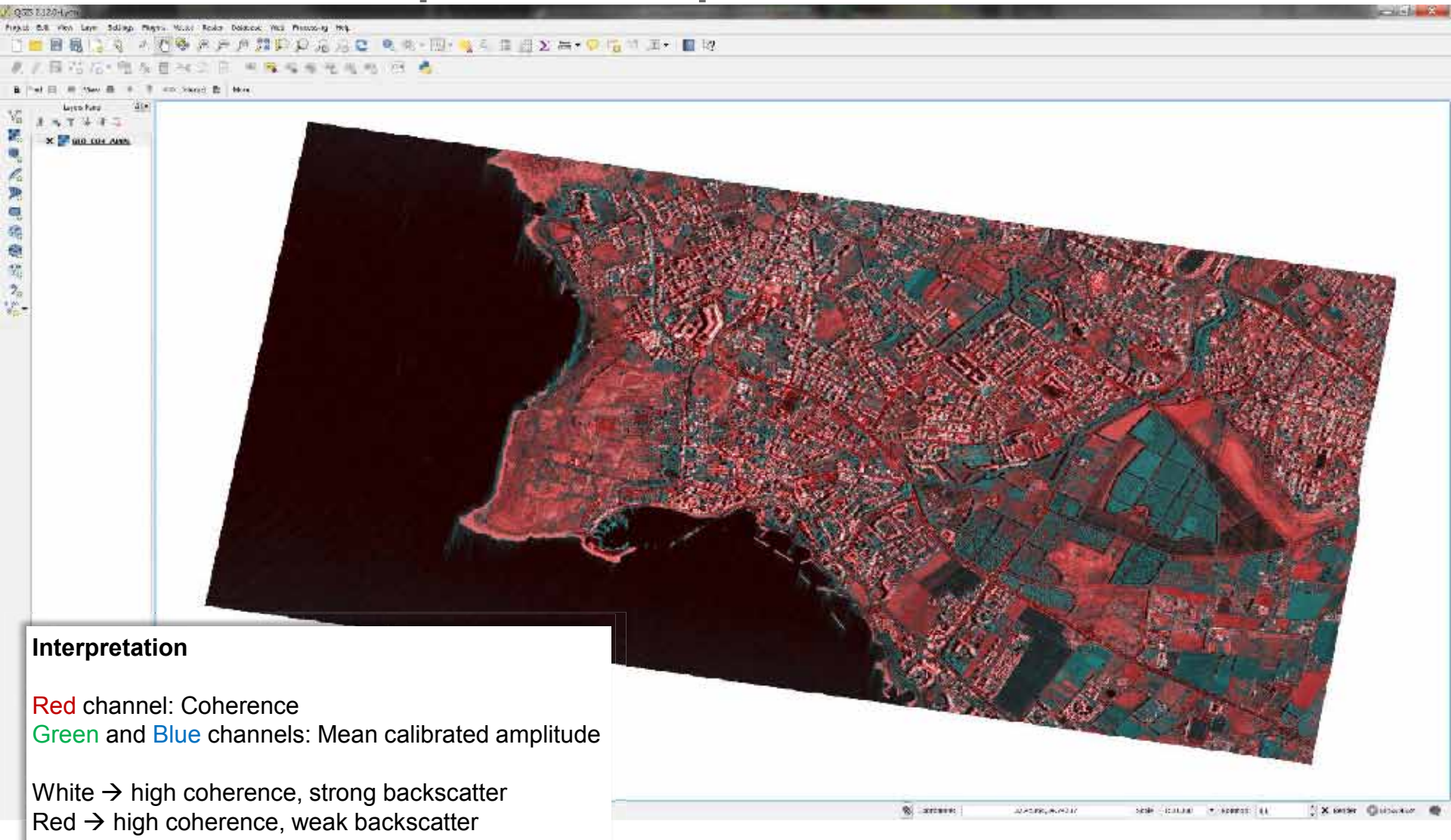

Interpretation

Red channel: Coherence
Green and Blue channels: Mean calibrated amplitude

White → high coherence, strong backscatter
Red → high coherence, weak backscatter
Green → low coherence
Black → low coherence, weak backscatter

TanDEM-X CoSSCs (Bistatic Stripmap)

- Data as downloaded from EOWEB
 - dims_op_oc_dfd2_513387009_1.tar.gz from 16.12.2013
 - dims_op_oc_dfd2_513387009_2.tar.gz from 05.04.2014
 - dims_op_oc_dfd2_513387009_3.tar.gz from 14.10.2012
 - dims_op_oc_dfd2_513387009_4.tar.gz from 23.08.2011
- In-house processing for
 - dims_op_oc_dfd2_513387009_2 (CoSSC_37743D_20140405T035529)
 - dims_op_oc_dfd2_513387009_3 (CoSSC_29583A_20121014T154741)



TanDEM-X CoSSCs (Bistatic Stripmap) DIMS Directory Structure

Previews format:
geocoded GeoTIFF (GTC)
radar geometry GeoTIFF (SLT)

Interferometric and
DEM previews

SAR data previews

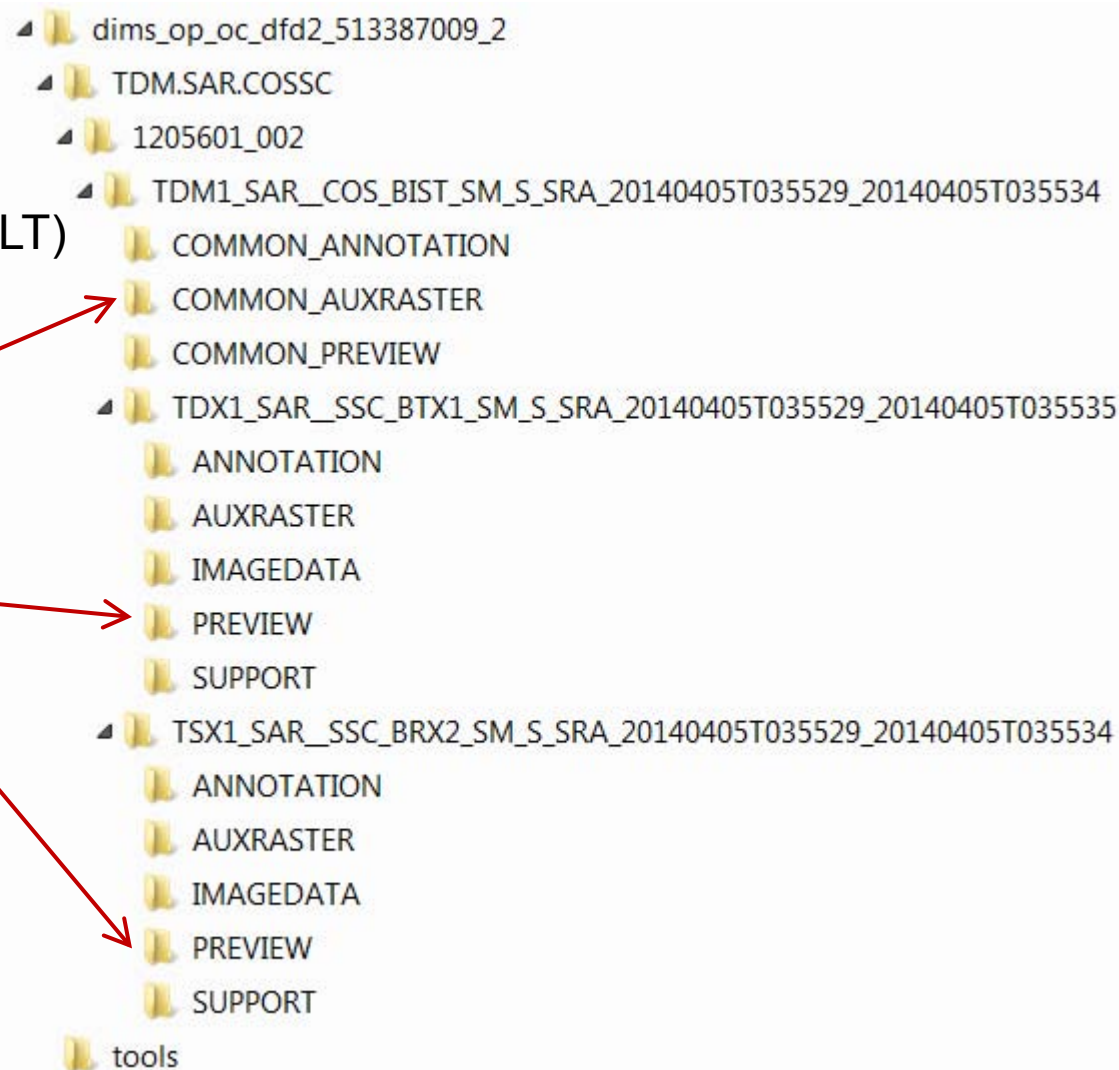

TanDEM-X CoSSCs (Bistatic Stripmap) DIMS Preview Examples

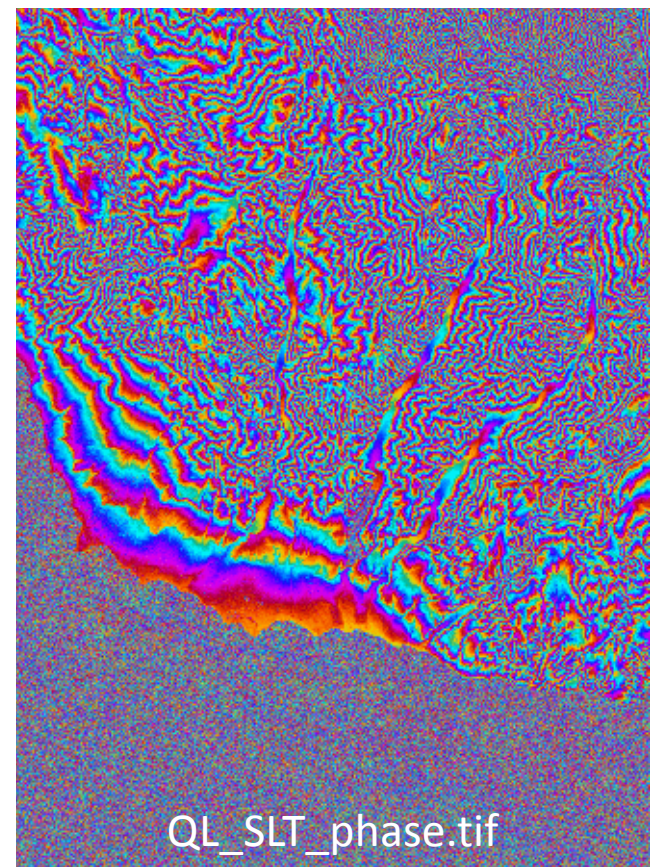
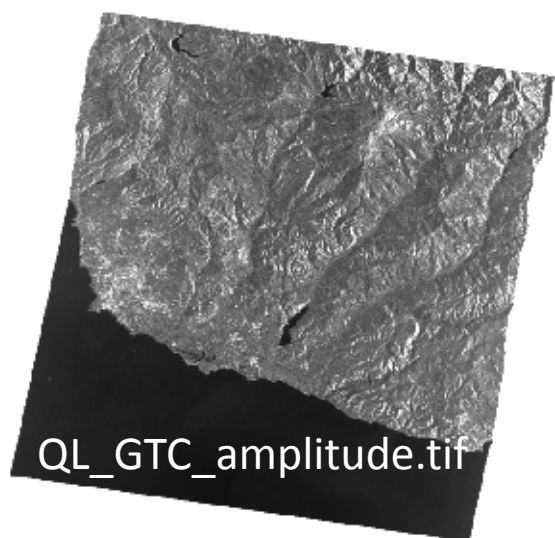

COMMON_PREVIEW – Interferometry and DEM



TanDEM-X CoSSCs (Bistatic Stripmap) In-house Processing Examples

- All results located in subdirectory “exportdir”

Name	Sensor Mode	Orbit	Incidence Angle	Pass Direction	Acquisition Times	Temporal Baseline (days)	Effective Baseline (m)	Height of Ambiguity (m)	Ground Resolution (m)
CoSSC_29583A_20121014T154741.tgz	SM	24	40.2	Ascending	14.10.2012	0	190.2	36.0	8
CoSSC_37743D_20140405T035529.tgz	SM	1	35.7	Descending	05.04.2014	0	89.3	66.8	9



TanDEM-X CoSSCs (Bistatic Stripmap) In-house Processing Examples

QL_GTC_DEM_3D_N.tif



TanDEM-X CoSSCs (Bistatic Stripmap) In-house Processing Examples

QL_GTC_DEM_3D_S.tif



TanDEM-X CoSSCs (Bistatic Stripmap) In-house Processing Examples

QL_GTC_DEM_hres.tif

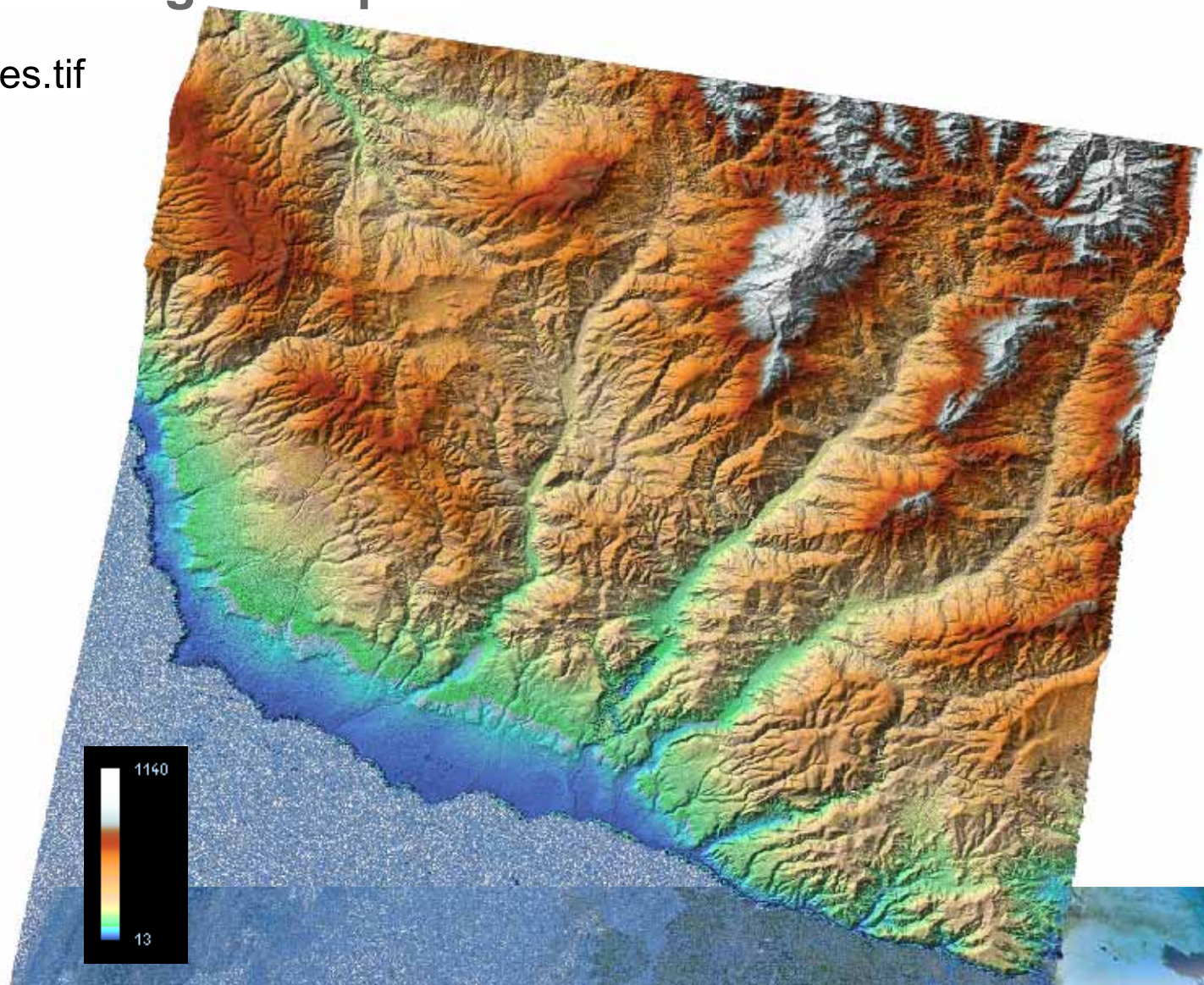

DLR

TanDEM-X CoSSCs (Bistatic Stripmap) In-house Processing Examples

QL_GTC_DEM_hres_amp.tif

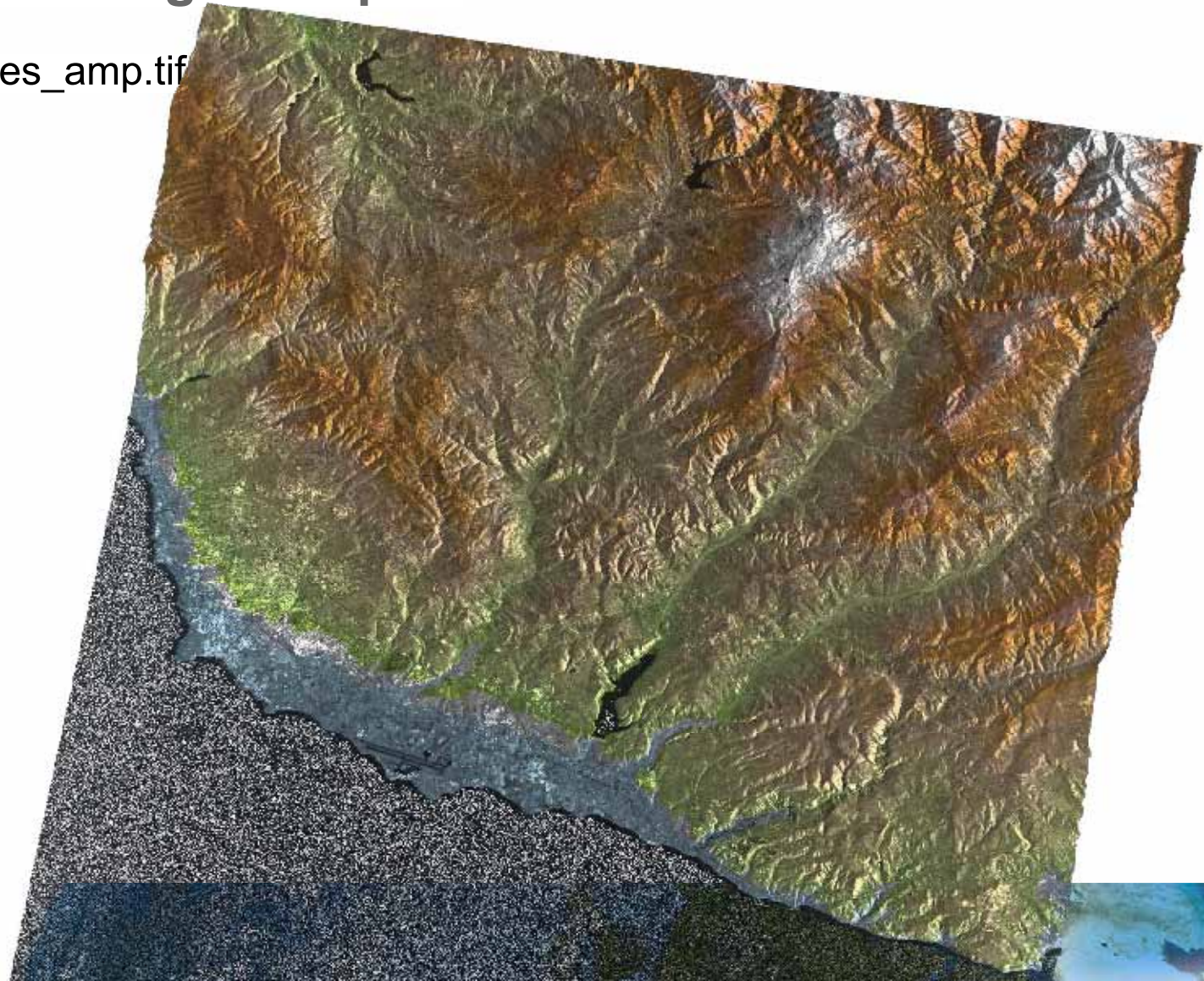

Sentinel-1 – IW

- In-house processing with same directory structure as TerraSAR-X ST (SSC). HTML and Google Earth overviews, results in GeoTIFF format.

Name	Sensor Mode	Orbit	Incidence Angle	Pass Direction	Acquisition Times	Temporal Baseline (days)	Effective Baseline (m)	Height of Ambiguity (m)	Ground Resolution (m)
IW_160A_20160103_20160115.tgz	IW	160	39.6	Ascending	03.01.2016 15.01.2016	12	10.2	1525	100
IW_167D_20160104_20160128.tgz	IW	167	39.7	Descending	04.01.2016 28.01.2016	24	57.0	273	100



ERS PSI

- [master_selection_overview\ms_web_visu\overlap.html](#)
 - HTML overview of master selection
- [wap_overview\wap_visualization.html](#)
 - HTML overview of PSI processing



ERS PSI

- [ge_wap_overview.kmz](#)
 - Google Earth overview of InSAR stacking
- [PSI_ESTIMATES_3797\CLUSTER_0\visu_google.kmz](#)
 - Google Earth overview of linear deformation



ERS PSI

- PSI_ESTIMATES_3797\CLUSTER_0\ps_final_result.shp
 - linear deformation shapefile
- PSI_ESTIMATES_3797\CLUSTER_0\DERAMPED\deramped.shp
 - linear deformation shapefile (deramped)

