

# THE DESIGN AND IMPLEMENTATION OF AN IN-APPLICATION AUTOMATED TESTING AND EVALUATION SYSTEM FOR COMPUTER LITERACY SKILLS BASED ON THE EUROPEAN & INTERNATIONAL COMPUTER DRIVING LICENCE (ECDL/ICDL)

Masouras Panicos<sup>1</sup>, Avgousti Sotiris<sup>2</sup>

<sup>1</sup>Senior Lecturer, Cyprus University of Technology (CYPRUS)

<sup>2</sup>Instructor, Cyprus University of Technology (CYPRUS)  
panicos.masouras@cut.ac.cy, sotiris.avgousti@cut.ac.cy

## Abstract

The increasing demand for computer literacy skills worldwide led into the introduction of certification models which, in turn, contributed to the development of the corresponding assessment tools and systems. With the ECDL at the forefront of the international computer literacy skills market and with its important role in the specification of digital literacy agenda, it becomes vitally important to ensure that assessment systems leading to this qualification are of the highest technical and pedagogical quality. This paper presents the experiences gained from the design, testing and implementation of such an assessment system and its deployment in a big-bang approach on a national basis in Cyprus. It explains the system's technical architecture and components, its functionalities and services and discusses the pedagogical and educational aspects embedded in the design and highlights the pitfalls and lessons learned in the areas of team building and project

**Keywords:** computer skills, computer literacy, assessment, computer assisted testing, formative, summative.

## 1 INTRODUCTION AND BACKGRDOUND

People of all ages, students at all levels of the educational system, employees and managers in all types of organizations, use computers and information communication technologies (ICTs) for activities ranging from completing school assignments, carrying out routine work at the office, making management decisions, socializing on the internet.

### 1.1 Computer literacy

Computer skills have not only become vital for employment and equal access to government and business services but they have become critically important for survival and personal well being in the 21<sup>st</sup> century.

The notion of computer literacy has been highlighted by governments, organizations and business alliance stakeholders. The European Union Member Countries, in response to the European Union Lisbon Strategy [7] and to initiatives and action plans such as [7,8,11,12] which identified the lack on ICT skills among European citizens and called for 'digital convergence' [12] and digital literacy, prepared e-strategies which included specific measures and actions for the up-skilling of their citizens and their SMEs.

So, for example the Ministry of Finance of the Republic of Cyprus [12] apart from taking the required measures for the improvement of technological infrastructures in schools and under the objective 'Promote Inclusion (e-Learning, Life-long Learning, Electronic Literacy' has implemented the measure of training and certification of teachers based on the ECDL standard and planned the reform of the educational curriculum to include use of ICT tools.

The [20] building on its previous initiatives under the Flagship Initiative 'A Digital Agenda for Europe' aims, among others, 'to promote internet access and take-up by all European citizens, especially through actions in support of digital literacy and accessibility.' while it urges Member States 'to promote deployment and usage of modern accessible online services (e.g. e-government, online health, smart home, digital skills, security).' At national level, member states will have to revise their National Reform Programmes of "e-Countryname" to comply with the newly set targets and aims.

On the industry side, with the vision of 'Fostering 21st century e-skills and digital literacy of Europe's workforce and citizens for a competitive, innovative and inclusive Europe', the [22] brings together

leading ICT vendors to contribute to the development and implementation of a long term e-skills and digital literacy agenda in Europe.

Some definitions of computer literacy focus on two areas: “whatever a person needs to know and do with computers in order to function competently in our society” [45] and “a measure of competency to exploit computer technology” [46] as cited by [47] The search for computer literacy has its beginning in elementary school [48,49]. In addition, computer literacy has now become a global issue [49, 50]

A similar definition was adapted by [28] as cited by [2] and according to which ICT literacy is defined as:

‘the ability of individuals to use ICT appropriately to access, manage, integrate and evaluate information, develop new understandings, and communicate with others in order to participate effectively in society’(p.1).

In their recent work [13] identify a variety and diversity on the approaches related to the term e-Competences and they elaborate on five definitions relating to it; namely ‘e-awareness, technological literacy, informational literacy, digital literacy and media literacy’. [13]’s distinctions of e-competences confirm [51] that computer literacy has evolved with time as technology improved and society became more dependent on computers. Some decades ago when a computer existed only in universities and in a limited number of organizations computer literacy meant being able to write a computer program in assembly language where as today, when personal computers, laptops, net-books and personal digital assistants are a commodity, computer literacy simply relates to being able to use the computer efficiently.

[13] elaborate on ‘technological literacy’ according to which a user is equipped with confidence in operating ICT applications ranging from the standard office applications to popular digital devices. It is important to note that [13] identify only the ‘ECDL or EPICT’ as the ‘formal environments’ in which this level of literacy can be acquired. A similar elaboration is presented by [30] who identifies database concepts, general computer concepts, Internet concepts, presentations, spreadsheets, web authoring, word processing as key areas of computer literacy.

## **1.2 Computer literacy assessment models**

Evidence shows that existing computer literacy assessment tools build on these definitions. Typical examples include the introductory awards for computer users, which assess competence in the use of common IT applications; examples include the ITQ (Information Technology Qualification) designed by e-skills UK; OCR’s CLaIT (Computer Literacy and Information Technology) certificate, the European Computer Driving Licence (ECDL), City & Guilds Certificate for IT Users, Edexcel Diploma in Digital Applications (DiDA). [25]

## **1.3 The case of ECDL – European Computer Driving Licence**

The ECDL/ICDL is managed internationally by the ECDL Foundation, a not-for-profit organization based in Dublin. To acquire the ECDL qualification a person has to succeed in seven tests, one theoretical and six practical. The practical tests are taken on the computer and relate to the most common office applications used both in the office and at home, by young students, employees and professionals in all areas of the business environment.

The ECDL [15] is considered today to be the most widely and internationally recognized computer skills certification for end-users. It is considered as the de facto pan-European standard for measuring end-user basic ICT skills. Known as the ICDL – International Computer Driving Licence in the countries outside Europe, it is offered in more than 140 countries, in five continents. With a structured syllabus translated in over 40 different languages and with a network of more than 30000 approved TCs worldwide it has become a universally acceptable model for assessing computer skills. With an ever increasing base of ten million holders of the certificate, it can be claimed that ECDL/ICDL constitutes the most massive and active community of computer learners globally.

Numerous international studies [24,10,12, 25,29] make reference to the ECDL recognizing its role as a best practice of computer literacy and its importance in the education systems and the business world. A brief review reveals an important guideline of [9] relating to the ECDL:

‘Member States, in partnership with private actors, should provide incentives for the unemployed to get a recognised certificate of basic ICT skills, like the European Computer Driving Licence (ECDL)’.

The [24] has also recommended to the Commission:

'That the ECDL be accepted as a Europe wide basic IT accreditation scheme, fulfilling the referenced eEurope2002 action line intention, without prejudice to either existing national schemes or the possibility of including other schemes. Moreover, the future direction of a European basic IT skills diploma should be further elaborated under the "eLearning action plan" as envisaged there.'

[38] report for CEDEFOP that

'The ECDL Foundation has created a widely respected set of quality guidelines for the creation of syllabi and the conducting of tests.'

and that

'the ECDL possesses significant recognition at European and International Level.'

## **2 E-ASSESSMENT FOR ECDL**

As with so many other terms to which the prefix 'e' was attached to, e-Assessment is an adaptation of the original concept, in this case assessment, to the electronic domain. It is used to remind us and highlight the specific features that electronic assessment provides to the assessment process compared to the paper-based and human-based versions. Although the term 'e-Assessment' is relatively new, a large number of studies during the last quarter of the century have investigated test mode effects on results [36]. The term appears in literature and [39] under different names which combine the words Computer, Assisted or Aided, Test, Assessment and Base, namely; Computer Based Testing (CBT), Computer Assisted Testing (CAT), Computer Aided Testing (CAT), Computer Based Assessment, Computer Assisted Assessment etc.

The development of e-assessment systems for ECDL is based on a set of quality guidelines issued by the ECDL Foundation which also undertakes the evaluation task in order to provide the required approval to the vendors interested to develop such systems. Despite its huge worldwide success the ECDL has not managed, yet, to establish a unique, universal and standard assessment model. This practically means that in some countries ECDL tests are manually assessed by assessors where as in other countries ECDL assessment is computer based. Within the ECDL community, such e-assessment models are referred to as Automated Testing and Evaluation Systems (in brief, ATES). All types of ATES consist of a user interface which embeds the application software, the question presentation modal which delivers questions to the test candidate and an evaluation engine which assesses the result of the activity of the candidate. They usually come integrated with a full candidate administration and registration system.

Due to the nature of the ECDL content, the software used for testing are primarily the various software versions of [27] suites although the [53] suites in combination with [54] could also be used. Within the ATES domain we can identify two different approaches in their implementation which are based on:

- a) simulation techniques (called in brief as SIM-ATES). These systems simply simulate the application software's environment and present only limited functionality to the user as required by the particular test questions. Although in many cases these systems appear to be impressive and resemble to a very high degree to the actual application software, a closer look immediately reveals their limitations.
- b) the full operation of the actual application software. So, if a candidate is to be tested for his skills in word processing, then the application software installed on the candidate's personal computer, in this case MS Word or Star Word will launch and fully operate during the whole testing process. The application will run in real time and the test candidate will solve the test working within the application itself. Thus, the term In-Application Automated Testing and Evaluation System (InA-ATES) is proposed. In parallel to the application and in full transparency, the testing and evaluation engine is running.

### **2.1 The business need for an ECDL Cyprus InA-ATES**

As referenced in their recent work, Wang et al. [36] the reasons for the rising popularity of computer-based testing include immediacy of scoring and reporting, test security and efficiency, reduced cost for administration. In addition to the above reasons, the requirement to respond to the high level of

demands for computer skills testing at European and international levels led to the development and wide use of e-Assessment tools and systems for the above mentioned qualifications.

For the case of Cyprus, the whole workflow operations of ECDL were completely manual until 2008 when the online ECDL Cyprus Examination Management System (EMS) which allowed TCs to simply reserve their exams online was introduced. This system was the first step towards the full automation of the operations and its successful launch in June 2008 paved the way for the design and implementation of the second component, the InA-ATES. The turn to InA-ATES was primarily dictated by the increasing demand for testing which was turned down and evidently led to loss of financial benefits, the pressure from the ECDL TC and candidates who expressed their disappointment due to the delays in the publication of results and printing of certificates. It was also mandated in realization of the fact that the introduction of more Test Supervisors (TS) and Test Evaluators (TE) would not solve the above problems but would rather reinforce the belief of the TCs that their recommendations for evolution of the testing processes were not taken into consideration. A third dimension of the problem related to the overall administration process which, having reached its limits, demonstrated its first signs of its maturity and called upon the management for innovation.

[5] explains that in the same way that technology is important and critical to learning, it will soon become equally vital to assessment. As cited by [34], and referenced by [52] are strongly convinced that Computer-based tests (CBT) are seen as “the future of testing”.

Demand for ECDL testing has been steadily increasing year by year since 1999. The original manual testing reached a level of maturity and the administrative overheads for its continuation were prohibitive at a level where the overall success of the ECDL project in Cyprus would be jeopardised. As an ECDL tester correctly stated at one meeting “the ECDL will collapse from its great national success”!

### **3 SYSTEM DESIGN DECISIONS**

#### **3.1 Integrating pedagogical issues in system design**

It is not our intention in this paper to investigate and discuss the concepts of formative and summative assessment but in practical terms we adopt Bull and McKenna [41] in their statement that computer assisted assessment offers a bridge between formative and summative assessments and that the line between them is blurred and the timely utilization and exploitation of marking and feedback.

Feedback as an attribute of formative assessment is a component within the learning process provided either by peers or teachers or the learning environment itself. [42] identify the provision of feedback that moves learners forward as a key and strategic aspect of formative assessment.

InA-ATES can be considered as fundamentally and primarily summative assessment tools. They are offering pure assessment of learning and measure the performance of test candidates on a particular application's test set of questions. A preliminary review of some of the available ECDL InA-ATES [1,6,16,17,19,35,37] indicates that these systems, although technically, technologically sound and in some areas innovative, they do not embed any formative assessment techniques. An unsuccessful assessment mandates the repetition of the learning and assessment cycle and feedback becomes fundamental for the potential success of the candidate in subsequent test attempts. Recognizing the principle that every assessment model must be candidate-centric, the provision of feedback was considered by the project team as one of the cornerstones for the design of the system. To this end, and in contrast with other systems, the system provides a detailed results feedback report for each candidate indicating the reference items of the ECDL syllabus for each test question, the duration taken by the candidate to resolve the question, the mark (0 or 1) and the question status (answered, not answered or ignored). Analysis of the data provided can serve the post and self-assessment process which each candidate, in cooperation with the trainer, has to perform. The aim of this activity would be to identify gaps of knowledge and weak areas in which the candidate has to pay further attention and plan his further learning upgrade. Equally important is that the information provided can be directly linked and mapped to the ECDL Syllabus [15] and the learning objectives, thus offering unique information to trainers to identify the areas in which additional exercises and work must be prepared for those candidates who may have failed.

Having in mind that not all candidates will pass the test right on the first time, this approach is also recommended by [40] who argues that “feedback or ‘knowledge results’, is the life-blood of learning”

which enables a learner to identify strengths, weaknesses in knowledge areas and guide him to enhance the former and plan for improvements on the latter.

Furthermore, in today's classroom there is a misalignment between the way people are learning and the way they are assessed. Students are learning a number of topics in parallel, revisiting and reflecting on resources in order to fully comprehend concepts and theories. Black and William [3,4] demonstrated that well designed formative assessment can lead to major benefits in student attainment on a wide range of conventional measures of attainment and this is independent of the discipline of the learner. The notion of "orderly learning" simply does not fit with the modern learning environments. Equally important, when it comes to assessment using traditional paper-based methods, students have the flexibility to answer the questions starting from any part or question in the test, spend as much time they feel they require on a question, revisit their work and reflect on theories to confirm the correctness of their action.

The above discussion reaffirmed the decision to provide flexibility so as to allow candidates to attempt any question in any order and without any constraint or limitation on the time a candidate could dedicate on a question or the number of times he would attempt a question. It was, of course, evident that the candidate should be warned and be aware of the simple fact that time management strategies during assessment are vital for success. Implementation of these pedagogical aspects required a detailed review of the test questions in the various syllabus modules. It was concluded that in order to make the implementation feasible questions should be as independent from one another as possible. So, in addition to the standard navigation from one question to the next, the system allows the selection of questions and their solution in any order. The questions are presented highlighted in different colours according to their current status.

<b>Test Center:</b> State Training Center, Platy		<b>Session:</b> 07.05.2010, 16:30 (675835)		
<b>Candidate ID :</b> 64776807		<b>Module:</b> M5 - Database(M5) <b>Mark:</b> 75% (Passed)		
<b>Candidate Results Feedback Report - TEST QUESTIONS</b>				
<b>Ques.#</b>	<b>Syllabus Knowledge Area</b>	<b>Grade</b>	<b>Duration</b>	<b>Status</b>
1.	5.1.1 Database Concepts	0	17	Answered
36	5.4.3 Printing	1	28	Answered
<b>Total Questions:</b> 36   <b>Correct:</b> 24   <b>Wrong:</b> 11   <b>Ignored:</b> 1   <b>Not Answered:</b> 0				

**Fig 1:** Snapshot of Candidate Results Feedback Report

These facilities resemble the way candidates actually act in the learning environment bringing an alignment with the tools and methods used during InA-ATES assessment. They also respond positively to [33]'s valid concerns on the matter. It can also be claimed that their existence may also lead to better test performance; this is a question which needs to be researched.

**Double click on the question to try again**

No.	Question	Status	Grade
1	Which of the available items is collected in a database? (One answer is correct)	IGNORED	0
2	Which of the available options describes the organisation of a database? (One answer is correct)	IGNORED	0
3	Which of the available options describes the function of the index? (One answer is correct)	IGNORED	0
4	Which of the available options is the purpose of a primary key? (One answer is correct)	NOT ANSWERED	0
5	Which of the available options is the purpose of relating tables in a database? (One answer is correct)	NOT ANSWERED	0
6	Create a query using all fields from the Students table to display all records with the Seattle City. Save the query as Seattle.	NOT ANSWERED	0
7	Create a form using all the fields from the Students table. Accept the default settings. Save the form as Students Form and leave it open.	NOT ANSWERED	0
8	To remove a filter from a table...	NOT ANSWERED	0
9	Create a report using the ClassID, Exam fields from the Assignments table, and the ClassName, Year fields from the Classes table. Accept the default settings and leave the report open.	NOT ANSWERED	0
10	Apply referential integrity between the Students and the Students And Classes tables.	NOT ANSWERED	0

11:45      End test

**Fig. 2:** Interface for selecting test questions from a list in any order

### 3.2 Creating the test sets

In a manual testing environment the candidate is utilizing one major work file on which he applies his knowledge and skills to solve the questions presented in the test paper in a series. As the candidate progresses the work file is gradually extended and enhanced reflecting the candidate's work. The candidate can assess, to some degree, his status and progress by looking at the differentiation of his work file from one question to the next.

Skipping a question to solve the next is, of course, allowed but returning to revisit a skipped question is not a trivial action any more. This is because, the content of the work file may have changed to such a degree that the candidate's action to solve this skipped question may not be applied to the correct content of the work file.

To implement the same scenario in an InA-ATES environment would require having one work file to be saved after the candidate solves each question. An attempt to prototype such a solution led into many design complexities and it was abandoned. The solution given was based on the always working rule of "keeping things simple". Each test would consist of thirty six unique questions with no dependency from one to the next. This would allow implementing the evaluation of each question independent from the previous or next work of the candidate. This simple approach and solution also facilitated the flexibility in the navigation process among questions, kept the utilisation of system resources to the minimum and it caused no limitations to the candidates' numerous attempts to solve a question.

The system includes a large number of multi-part questions which are currently evaluated by giving 1 or 0 marks only. However, pedagogically this is considered unfair. To this end, a detailed review of the questions database is in progress in order to develop a "fairness-formula" which will allow the allocation of marks to the distinct parts of the questions.

### 3.3 The ECDL InA-ATES test development life cycle

For the effective development of tests a rigorous and interactive process was established which allowed the rapid development, testing and quality assurance of the test questions and their registration in the Questions Test Base, an integral part of the InA-ATES Engine.

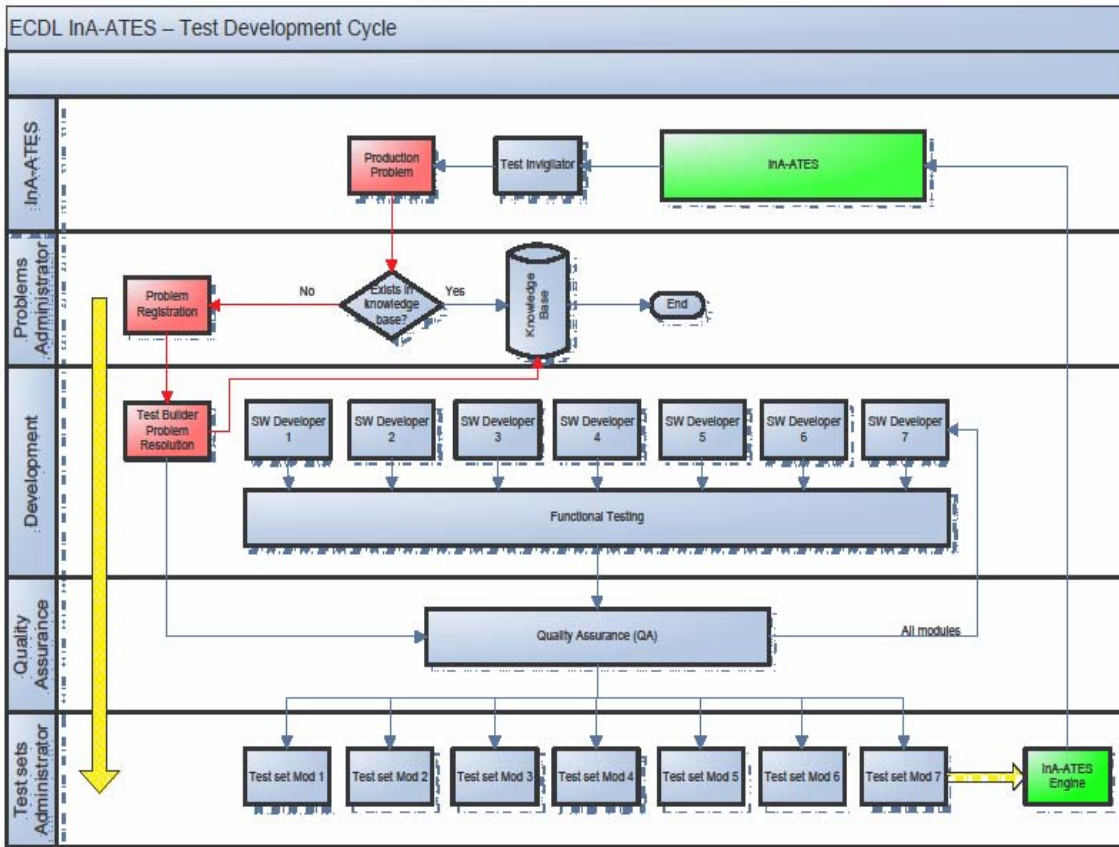

Fig. 3: ECDL InA-ATES Test Development Life Cycle

## 4 TECHNICAL ARCHITECTURE AND SYSTEM COMPONENTS

The technical architecture of the system exploits the web based EMS – Exams Management System responsible for the registration and management of exam sessions and candidates. The EMS interfaces with the Exams Manager application which resides locally in each TC lab to which a number of clients are connected. The TS downloads the exam sessions for the particular lab on its exam manager, distributes the tests to each of the clients where the candidates sit and take their exam. On completion, the TS collects the results from the client onto the Exam Manager and then uploads the results to the EMS for subsequent viewing by the candidates.

### 4.1 System features

The system provides for an extensive set of features which can satisfy the business requirements of any type and size of a TC or even an ECDL national operator. Specifically it supports direct linking to the ECDL Syllabus and the defined learning objectives, multi-location and multi-test laboratory support, transparent use of multiple MS Office and MS Windows platforms within the same test lab, an intuitive and trivial user interface, support for people with special needs, integration with a candidate registration, administration and reporting systems and dual language question support.

### 4.2 User interface design

The intuitiveness of the user interface was discussed extensively among the development team members in view of the fact that the system would be utilised by a large number of candidates of all ages, different educational backgrounds and variable computer experiences. Winning the candidate by providing him with a simple user interface with the minimum possible options which would allow him to carry out the test process effectively was an easy decision to reach. For this first release of the system, however, it was decided that no customization of the user interface would be provided. The user interface consists of a number of easily understandable buttons whose functionality is self-



explanatory.

Create a form using all the fields from the **Students** table. Accept the default settings. Save the form as **Students Form** and leave it open.

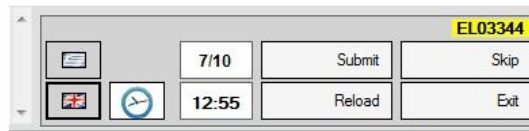

Fig. 4: The Intuitive User Interface with a loaded question

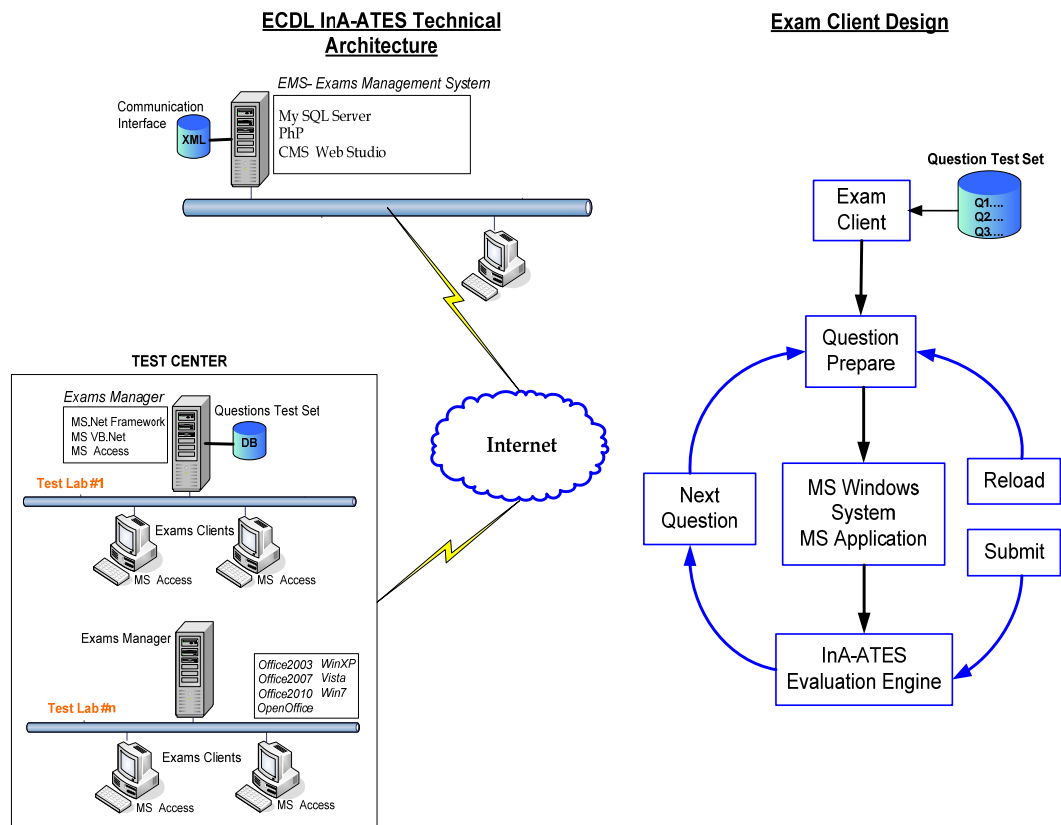

Fig. 5: InA-ATES Technical Architecture & Exam Client Design

### 4.3 System stability and reliability

One of the most impressive aspects of the system is its ability to recover from any point of failure allowing the candidate to transparently restart the test at the exact question and with the exact time left to completion as it was recorded at the time of failure. Such failures may be attributed to electricity power cuts or disruptions, system hang-up, accidental system power offs or system reboots. This functionality also solved a chronic problem of the manual system where in case of technical failure the candidate simply had to retake the exam. It also enhanced the candidates' and TC managers' confidence as to the technical superiority of the system.

### 4.4 Security

Ensuring the integrity and validity of the test process is a fundamental principle for the maintenance of the high quality standard of the ECDL concept worldwide. A number of measures and policies have been implemented which, in combination with the controls performed by the system itself ensures that the testing process is carried out effectively and that no unauthorized candidate can take the test.



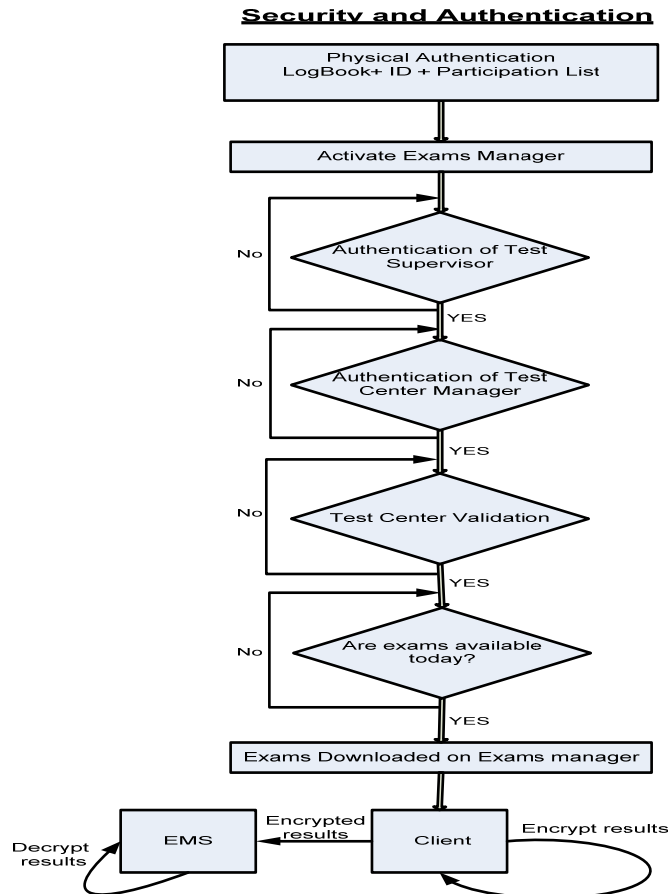

**Fig. 6:** Candidate Authentication & InA-ATES Security Controls

Encoding the results of the candidate and preventing illegal and unauthorized access and subsequent modification is a fundamental functionality of the system. The results file is encoded using the standard Triple DES cryptography algorithm [43] at the exam manager level and decrypted at the EMS level before storing the results in the EMS Database.

Security measures are also implemented during the actual test process. Specifically, the copy/paste and Print Screen facility of the operating system are disabled so that the question text can not be copied and saved in a document and no screen captures can be taken and stored for later review. Although every effort is made at the TC to ensure that the network and the exam clients are virus free, there is always a possibility that a virus may exist which may jeopardize the integrity of the candidates' results files. To this end, any attempt to modify the results' file size is monitored and reported and the results are not uploaded in case of such incident.

## 5 PROJECT MANAGEMENT

### 5.1 Team Building

The discussion on the formation of the project team initially focused on the fact that no full time personnel were employed. The experience of the ECDL testers who are fully qualified IT professionals with vast number of years of experience in systems development life cycles was exploited. The main criterion for the selection of the members of the team were attributed to their capability to work together, the ease of bond, their communication skills and their willingness to dedicate the required extra time as they were employed full time by other organizations.

### 5.2 Project Plan

A detailed project plan depicting the various project phases, the resources and the deadlines was prepared and monitored by the project manager.

Activity	Start Date	End Date	Resources
<b>Definition of ECDL Cyprus InA-ATES User Requirements</b>	09-Jun-08	13-Aug-08	ECDL Testers, ECDL Test Centres, ECDL Back Office, ECDL Trainers
<b>National Roll-Out</b>	01-Sep-09		Test Centres, ECDL Candidates, Bdigital

### 5.3 System development life cycle

The existing cohesion of the team members, a fundamental requirement for the effective application of the Rapid Application Development (RAD) Methodology [44] and the fact that the system would be delivered in phases led into the selection of an Incremental RAD approach to system development. During the project, team members were also acting as informed power users based on their collective and joint experiences as testers for over five to ten years.

### 5.4 Problems reporting and resolution

The early and active involvement of all stakeholders, TC Managers, trainers and candidates and the exchange of information about the problems, the presentation of solutions and alternative options, the active support to the TCs were of vital importance to the successful implementation of the project and the change management process. Different problems were reported at the various stages which related to the technical infrastructures at the TC, the InA-ATES itself which and were all investigated thoroughly by the technical team whose flagship was the one line phrase “zero problems at the TCs”.

### 5.5 System implementation and national rollout

The importance of this project was ranked by the management team as very high whose roll-out date of 1<sup>st</sup> September 2009 was immovable in view of the beginning of the new academic year, time when, the first tests are requested. The motto “a new school year, a new beginning, a new system!” was suggested and communicate to the TCs. The option to dessert the manual system and roll out the system on a national basis in a big-bang approach was actually an option second to none as it would free our resources and dedicate them fully to the support of the new system. This decision, actually served the interests of the TCs which were all treated as equal partners. It was also to the interest of the candidates as they would all have access to their test results within the same timescales.

## 6 CONCLUSIONS AND FUTURE DEVELOPMENTS

Although a formal evaluation of the system and a formal user satisfaction survey has not taken place yet, feedback received from TC managers, trainers and candidates on the quality of the system has been very positive. Following their first, mostly expected, reservations and reactions as to the level of candidates results in comparison with the results of the manual system; they soon realized that the tangible benefits offered on the overall organizational and educational aspects surrounding the learning and assessment process system reduced and mostly eliminated concerns. Their satisfaction on the project team’s readiness and responsiveness to provide detailed information and the common understanding that new systems need time for refinement and adaptation by all users involved, served in the change management process. The minimum number of technical problems encountered after the national roll-out and the immediate corrective actions taken raised the confidence of all towards the new system.

Enhancements have already been identified and are in the pipeline for review and potential implementation. These include a feature for multi-language support, implementation of an n-computing solution, customization of the user interface, enhanced facilities for people with disabilities and an open systems edition. The process of problem reporting and resolution worked quite successfully due to the dedication of the team members and the detailed reporting they maintained, mainly using an Excel spreadsheet. If is to take this system further then it is expected that a more professional approach to this issue will be followed. The successful implementation of the system opens new horizons for replicating its success in other markets, thus providing an opportunity for global co-operations equivalent to the success of the ECDL.

## **REFERENCES**

- [1] ACTIV. (2010) [Online] Available from: <http://www.activ-training.com/> [Accessed 7 April 2010]
- [2] Ainley, J., Fraillon, J., Freeman, C. & Murphy, M. (2008) National Assessment Program Information Communication And Technology Literacy, Year 6 And Year 10, Technical Report 2005. [Online] Available from: [http://www.mceecdya.edu.au/verve/\\_resources/NAP\\_ICTL\\_2005\\_Years\\_6\\_and\\_10\\_Report.pdf](http://www.mceecdya.edu.au/verve/_resources/NAP_ICTL_2005_Years_6_and_10_Report.pdf) [Accessed 22 March 2010]
- [3] Black, P.J. & Wiliam, D. (1998) Assessment and Classroom Learning. *Assessment in Education*, 5(1), 7-74.
- [4] Black, P.J. & Wiliam, D. (2002) Assessment for Learning: Beyond the Black Box [Online] Available from: <http://www.assessment-reform-group.org/AssessInsides.pdf> [Accessed March, April 2010]
- [5] Bennett, R. E. (2002). Inexorable and inevitable: The continuing story of technology and assessment. *Journal of Technology, Learning, and Assessment*, (1)1, 1-23.
- [6] Bitmedia, (2010) [Online] Available from: <http://www.bitmedia.cc/en/> [Accessed 7 April 2010]
- [7] Commission of the European Communities. (2000) *e-Europe An Information Society for All*. Commission of the European Communities.
- [8] Commission of the European Communities. (2001a) *e-Europe+ 2003 A co-operative effort to implement the Information Society in Europe - Action Plan prepared by Member States*. Commission of the European Communities.
- [9] Commission of the European Communities. (2001b) *e-Inclusion: The Information Society's potential for social inclusion in Europe*. Commission of the European Communities.
- [10] Commission of the European Communities. (2002) *Commission's Action Plan for skills and mobility*. Commission of the European Communities.
- [11] Commission of the European Communities. (2003) *eEurope 2005: An information society for all*. Commission of the European Communities.
- [12] Commission of the European Communities. (2005) *i2010 – A European Information Society for growth and employment*. Commission of the European Communities.
- [13] Cristobal, J. & Romani, C. (2009) Strategies to Promote the Development of E-Competencies in the Next Generation of Professionals: European and International Trends. *Skope*. [Online] 19-21. Available from: <http://www.cardiff.ac.uk/socsi/research/researchcentres/skope/publications/monographs/monograph13.pdf> [Accessed May 2010]
- [14] Dolan, D. (1998) European Computer Driving Licence. In: Marshall, G. & Ruohonen, M. (eds) *Capacity building for IT in education in developing countries: IFIP TC3 WG*. Chapman & Hall, pp. 213-220
- [15] ECDL Foundation. (2010) [Online] Available from: <http://www.ecdl.org> [Accessed May 2010]
- [16] ECDL Foundation Portal. (2010) [Online] Available from: <http://portal.ecdl.org> [Accessed May 2010]
- [17] ECDL Hellas. (2010) [Online] Available from: <http://www.ecdl.gr/el/Pages/home.aspx> [Accessed May 2010]

- [18] The International ICT Literacy Panel. (2007) *Digital Transformation - A Framework for ICT Literacy*. Educational Testing Service.
- [19] EnlightKS. (2010) [Online] Available from: <http://www.enlightks.com/> [Accessed 21 March 2010]
- [20] European Commission. (2010) *Europe 2020: A European strategy for smart, sustainable and inclusive growth*. European Commission.
- [21] European Pedagogical ICT Licence. (2010) [Online] Available from: <http://www.epict.org> [Accessed May 2010]
- [22] e-Skills Industry Leadership Board. (2010) [Online] Available from: <http://www.e-skills-ilb.org/> [Accessed May 2010]
- [23] Government of the Republic of Lithuania. (2005) National Lisbon Strategy Implementation Programme. Government of the Republic of Lithuania.
- [24] High Level Group Employment And Social Dimension of the Information Society (ESDIS). (2001)
- [25] Leney, T. & Ponton, A. (2007) *OECD Thematic Review On Recognition Of Non-Formal And Informal Learning, Country Background Report*. OECD (Organisation for Economic Co-Operation And Development)
- [26] Litmus Learning. (2010) [Online] Available from: [http://www.litmuslearning.com/ltlg\\_2009.nsf/link/home.html](http://www.litmuslearning.com/ltlg_2009.nsf/link/home.html) [Accessed May 2010]
- [27] Microsoft Corporation, Microsoft Learning (2010) [Online] Available from: <http://www.microsoft.com/traincert/mcp/mous/default.asp> [Accessed May 2010]
- [28] Ministerial Council on Education, Employment, Training and Youth Affairs. (2007) *National Assessment Program – ICT Literacy - Years 6 and 10 Report 2005*. Melbourne: MCEETYA.
- [29] Organisation for Economic Co-Operation and Development. (2002) *OECD Information Technology Outlook - ICTs and the Information Economy*. OECD. Report number (year): 2002
- [30] Owens, B. (2003). Ethics and the Internet: A novel approach to computer literacy. *Journal of Computing in Small Colleges*, 18(4), 4-10.
- [31] Qualifications and Curriculum Development Agency. [Online] Available from: <http://www.qcda.gov.uk/6547.aspx> [Accessed May 2010]
- [32] Republic of Cyprus, Ministry of Finance. (2005) *National Lisbon Programme of the Republic of Cyprus*. Republic of Cyprus, Ministry of Finance.
- [33] Ridgway, J. & McCusker, S. (2004) *Literature Review of E-assessment*. Futurelab. Report number: 10.
- [34] Sterling, T. M. (2009) Literature review: Computer-based testing of reading. [Online] Available from: <http://ocs.sfu.ca/fedcan/index.php/csse2009/csse2009/paper/view/1951/614> [Accessed May 2010]
- [35] ThirdForce, (2010) [Online] Available from: <http://www.thirdforce.com/> [Accessed May 2010].
- [36] Wang, S., Jiao, H., Young, M., Brooks, T., & Olson, J. (2008). Comparability of computer-based and paper-and-pencil testing in K-12 reading assessments: A meta-analysis of testing mode effects. *Educational and Psychological Measurement*, 68, 5-24.
- [37] WebScience. (2010) [Online] Available from: <http://www.webscience.it/eng/index.html> [Accessed May 2010]

- [38] Weiß, P., Dolan, D., Stucky, W. & Bumann, P. (2005) *ICT-Skills Certification in Europe*. CEDEFOP.
- [39] Wikipedia. (2010) [Online] Available from <http://en.wikipedia.org/wiki/E-assessment> [Accessed May 2010]
- [40] Rountee, D. (1987) *Assessing Students: How shall we knowthen?* 2<sup>nd</sup> Edition, Kogan Page, London.
- [41] Bull, J. & McKenna, C. (2004) *Blueprint for computer-assisted assessment*. London: RoutledgeFalmer
- [42] Black, P. & Wiliam, W. (2009). Developing the theory of formative assessment. *Educational Assessment Evaluation and Accountability*, 21, 5-31.
- [43] Rapid Application Development (2010). [Online] Available from [http://en.wikipedia.org/wiki/Rapid\\_application\\_development](http://en.wikipedia.org/wiki/Rapid_application_development) [Accessed May 2010]
- [44] Triple DES cryptography algorithm (2010) ([Online] Available from [http://en.wikipedia.org/wiki/Triple\\_DES](http://en.wikipedia.org/wiki/Triple_DES) [Accessed May 2010]
- [45] Hunter, B. (1985) Computer Literacy, ERIC Document Reproduction Service No. ED 207 617, 1981, 27-28
- [46] Wolfe, B. (1983) Achieving Computer Literacy, Eleventh User Services Conference Proceedings, ACM, p.iis s.
- [47] Halaris, A. & Sloan, L. (1985) Towards a definition of computing literacy for the liberal arts environment. ACM SIGCSE Bulletin, Proceedings of the sixteenth SIGCSE technical symposium on Computer Science Education SIGCSE '85, 17(1), 320-326.
- [48] Albee, J. (2003). A study of preservice elementary teachers' technology skill preparedness and examples of how it can be increased. *Journal of Technology and Teacher Education*, 11(1), 53-71.
- [49] Asan, A. (2003). Computer technology awareness by elementary school teachers: A case study from Turkey. *Journal of Information Technology Education*, 2, 153-164. [Online] Available from: <http://jite.org/documents/Vol2/v2p153-164-109.pdf> [Accessed May 2010]
- [50] Csapo, N. (2002). Certification of computer literacy. *T H E Journal*, 30(1), 41-49.
- [51] Hoffman, M. & Blake, J. (2003). Computer literacy: Today and tomorrow. *Journal of Computing Sciences in Colleges*, 18(5), 221-233.
- [52] Kim, D. & Huynh, H. (2008). A Computer-Based and Paper-and-Pencil Administration Mode Effects on a Statewide End-of-Course English Test. *Educational and Psychological Measurement*, Vol. 68, No. 4, 554-570.
- [53] Open and Star Office (2010). [Online] Available from: <http://www.sun.com/software/openoffice/index.jsp> [Accessed May 2010]
- [54] Linux (2010). [Online] Available from: <http://www.linux.org/> Linux [Accessed May 2010]